

---

**UNITED STATES  
SECURITIES AND EXCHANGE COMMISSION**  
Washington, D.C. 20549  
**FORM 10-K**

(Mark one)

**Annual Report Pursuant to Section 13 or 15(d) of the Securities Exchange Act of 1934**  
For the fiscal year ended **December 31, 2021**

or

**Transition Report Pursuant to Section 13 or 15(d) of the Securities Exchange Act of 1934**  
For the transition period from \_\_\_\_\_ to \_\_\_\_\_

Commission file number **001-38630**

**Aridis Pharmaceuticals, Inc.**

(Exact name of Registrant as specified in its charter)

**Delaware**  
(State or other jurisdiction of  
incorporation or organization)  
**983 University Avenue, Bldg. B**  
**Los Gatos, California**  
(Address of principal executive offices)

**47-2641188**  
(I.R.S. Employer  
Identification No.)  
**95032**  
(Zip Code)

Registrant's telephone number, including area code: **(408) 385-1742**

Securities registered pursuant to Section 12(b) of the Act:

Title of each class	Name of exchange on which registered
Common Stock, par value \$0.0001 per share	The Nasdaq Capital Market

Securities registered pursuant to Section 12(g) of the Act: **None**

Indicate by check mark if the registrant is a well-known seasoned issuer, as defined in Rule 405 of the Securities Act. Yes  No

Indicate by check mark if the registrant is not required to file reports pursuant to Section 13 or Section 15(d) of the Act. Yes  No

Indicate by check mark whether the registrant: (1) has filed all reports required to be filed by Section 13 or 15(d) of the Securities Exchange Act of 1934 during the preceding 12 months (or for such shorter period that the registrant was required to file such reports) and (2) has been subject to such filing requirements for the past 90 days. Yes  No

Indicate by check mark whether the registrant has submitted electronically every Interactive Data File required to be submitted pursuant to Rule 405 of Regulation S-T (§232.405 of this chapter) during the preceding 12 months (or for such shorter period that the registrant was required to submit such files). Yes  No

Indicate by check mark if disclosure of delinquent filers pursuant to Item 405 of Regulation S-K is not contained herein, and will not be contained, to the best of the registrant's knowledge, in definitive proxy or information statements incorporated by reference in Part III of this Form 10-K or any amendment to this Form 10-K.

Indicate by check mark whether the registrant is a large accelerated filer, an accelerated filer, a non-accelerated filer, a smaller reporting company or an emerging growth company. See the definitions of "large accelerated filer," "accelerated filer," "smaller reporting company" and "emerging growth company" in Rule 12b-2 of the Exchange Act:

Large accelerated filer  Accelerated filer  Non-accelerated filer  Smaller reporting company   
Emerging growth company

If an emerging growth company, indicate by check mark if the registrant has elected not to use the extended transition period for complying with any new or revised financial accounting standards provided pursuant to Section 13(a) of the Exchange Act.

Indicate by check mark whether the registrant is a shell company (as defined in Rule 12b-2 of the Act). Yes  No

The aggregate market value of the registrant's common stock, held by non-affiliates of the registrant as of June 30, 2021 (which is the last business day of registrant's most recently completed second fiscal quarter) based upon the closing market price of such stock on the Nasdaq Capital Market on that date, was approximately \$72.5 million. For purposes of this disclosure, shares of common stock held by an officer, a director and an affiliated shareholder have been excluded in that such persons may be deemed to be "affiliates" as that term is defined under the Rules and Regulations of the Securities Exchange Act of 1934. This determination of affiliate status is not necessarily conclusive.

On April 11, 2022, the registrant had 17,701,592 shares of common stock outstanding.

**DOCUMENTS INCORPORATED BY REFERENCE**

Portions of the registrant's Proxy Statement for the 2022 Annual Meeting of Stockholders are incorporated herein by reference in Part III of this Annual Report on Form 10-K to the extent stated herein. Such proxy statement will be filed with the Securities and Exchange Commission within 120 days of the registrant's fiscal year ended December 31, 2021.

---

TABLE OF CONTENTS

	<u>Page</u>
<a href="#">Forward-Looking Statements</a>	3
<a href="#">Part I.</a>	
<a href="#">Item 1. Business</a>	5
<a href="#">Item 1A. Risk Factors</a>	46
<a href="#">Item 1B. Unresolved Staff Comments</a>	87
<a href="#">Item 2. Properties</a>	87
<a href="#">Item 3. Legal Proceedings</a>	87
<a href="#">Item 4. Mine Safety Disclosures</a>	87
<a href="#">Part II.</a>	
<a href="#">Item 5. Market for Registrant’s Common Equity, Related Stockholder Matters and Issuer Purchases of Equity Securities</a>	88
<a href="#">Item 6. Selected Financial Data</a>	88
<a href="#">Item 7. Management’s Discussion and Analysis of Financial Condition and Results of Operations</a>	89
<a href="#">Item 7A. Quantitative and Qualitative Disclosures About Market Risk</a>	99
<a href="#">Item 8. Financial Statements and Supplementary Data</a>	99
<a href="#">Item 9. Changes in and Disagreements with Accountants on Accounting and Financial Disclosure</a>	99
<a href="#">Item 9A. Controls and Procedures</a>	100
<a href="#">Item 9B. Other Information</a>	101
<a href="#">Part III.</a>	
<a href="#">Item 10. Directors, Executive Officers and Corporate Governance</a>	101
<a href="#">Item 11. Executive Compensation</a>	101
<a href="#">Item 12. Security Ownership of Certain Beneficial Owners and Management and Related Stockholder Matters</a>	101
<a href="#">Item 13. Certain Relationships and Related Transactions, and Director Independence</a>	101
<a href="#">Item 14. Principal Accounting Fees and Services</a>	101
<a href="#">Part IV.</a>	
<a href="#">Item 15. Exhibits and Financial Statement Schedules</a>	102
<a href="#">Item 16. Form 10-K Summary</a>	105
<a href="#">Signatures</a>	106

---

## FORWARD-LOOKING STATEMENTS

This Annual Report on Form 10-K (the “Annual Report”), contains forward-looking statements that involve risks and uncertainties. We make such forward-looking statements pursuant to the safe harbor provisions of the Private Securities Litigation Reform Act of 1995 and other federal securities laws. All statements other than statements of historical facts contained in this Annual Report are forward-looking statements. You can identify forward-looking statements by terminology such as “may,” “will,” “should,” “expects,” “intends,” “plans,” “anticipates,” “believes,” “estimates,” “predicts,” “potential,” “continue” or the negative of these terms or other comparable terminology.

Our operations and business prospects are always subject to risks and uncertainties including, among others:

- the timing of regulatory submissions;
- our ability to obtain and maintain regulatory approval of our existing product candidates and any other product candidates we may develop, and the labeling under any approval we may obtain;
- approvals for clinical trials may be delayed or withheld by regulatory agencies;
- preclinical and clinical studies will not be successful or confirm earlier results, meet expectations, meet regulatory requirements, or meet performance thresholds for commercial success;
- risks relating to the timing and costs of clinical trials, the timing and costs of other expenses;
- risks associated with obtaining third-party funding;
- risks associated with delays, increased costs and funding shortages caused by or resulting from the COVID-19 pandemic;
- management and employee operations and execution risks;
- loss of key personnel;
- competition;
- risks related to market acceptance of products;
- intellectual property risks;
- assumptions regarding the size of the available market, benefits of our products, product pricing, and timing of product launches;
- risks associated with the uncertainty of future financial results;
- our ability to attract collaborators and partners; and
- risks associated with our reliance on third-party organizations.

Any forward-looking statements in this Annual Report reflect our current views with respect to future events or to our future financial performance and involve known and unknown risks, uncertainties and other factors that may cause our actual results, performance or achievements to be materially different from any future results, performance or achievements expressed or implied by these forward-looking statements. Factors that may cause actual results to differ materially from current expectations include, among other things, those listed under Part I, Item 1A. “Risk Factors” and elsewhere in this Annual Report. Given these uncertainties, you

should not place undue reliance on these forward-looking statements. Except as required by law, we assume no obligation to update or revise these forward-looking statements for any reason, even if new information becomes available in the future.

This Annual Report also contains estimates, projections and other information concerning our industry, our business, and the markets for certain diseases, including data regarding the estimated size of those markets, and the incidence and prevalence of certain medical conditions. Information that is based on estimates, forecasts, projections, market research or similar methodologies is inherently subject to uncertainties and actual events or circumstances may differ materially from events and circumstances reflected in this information. Unless otherwise expressly stated, we obtained this industry, business, market and other data from reports, research surveys, studies and similar data prepared by market research firms and other third parties, industry, medical and general publications, government data and similar sources.

#### **Risk Factor Summary –**

Our business is subject to significant risks and uncertainties that make an investment in us speculative and risky. Below we summarize what we believe are the principal risk factors but these risks are not the only ones we face, and you should carefully review and consider the full discussion of our risk factors in the section titled “Risk Factors”, together with the other information in this Annual Report on Form 10-K. If any of the following risks actually occurs (or if any of those listed elsewhere in this Annual Report on Form 10-K occur), our business, reputation, financial condition, results of operations, revenue, and future prospects could be seriously harmed. Additional risks and uncertainties that we are unaware of, or that we currently believe are not material, may become important factors that adversely affect our business.

*We expect to continue to incur increasing net losses for the foreseeable future, and we may never achieve or maintain profitability.*

*Our consolidated financial statements include an explanatory paragraph that expresses substantial doubt about our ability to continue as a going concern, indicating the possibility that we may not be able to operate in the future.*

*Available cash resources may be insufficient to provide for our working capital needs beyond the next twelve months.*

*We will require substantial additional capital in the future. If additional capital is not available, we will have to delay, reduce or cease operations.*

*If we fail to successfully complete clinical trials, fail to obtain regulatory approval or fail to successfully commercialize our product candidates, our business would be harmed and the value of our securities would decline.*

*We, or our collaborators, may face delays in completing our clinical trials, and may not be able to complete them at all.*

*Our development of a COVID-19 therapeutic candidate is at an early stage and we may not be able to successfully develop an effective therapeutic to treat COVID-19 in a timely manner to maximize the commercial market opportunity, if at all.*

*If we encounter difficulties enrolling patients in our clinical trials, our clinical trials could be delayed or otherwise adversely affected.*

*Clinical development is a lengthy and expensive process with an uncertain outcome, and results of earlier studies and clinical trials may not be predictive of future trial results.*

*We have no experience manufacturing our product candidates at commercial scale, and there can be no assurance that our product candidates can be manufactured in compliance with regulations at a cost or in quantities necessary to make them commercially viable. There can be no assurance that any contract manufacturing facilities will be acceptable for licensure by regulatory authorities or that we can contract to build acceptable facilities.*

*Our contract manufacturers are subject to significant regulation with respect to manufacturing of our products.*

*We rely on relationships with third-party contract manufacturers and raw material suppliers, which limits our ability to control the availability of, and manufacturing costs for, our product candidates.*

*A pandemic, epidemic or outbreak of an infectious disease, such as COVID-19, may materially and adversely affect our business and operations.*

*If our joint venture with Hepalink is not successful or if we fail to realize the benefits we anticipate from such joint venture, we may not be able to capitalize on the full market potential of our products in China, Hong Kong, Macau and Taiwan.*

*We compete in an industry characterized by extensive research and development efforts and rapid technological progress. New discoveries or commercial developments by our competitors could render our potential products obsolete or non-competitive.*

*Our competitors may develop and market products that are less expensive, more effective, safer or reach the market sooner than our product candidates, which may diminish or eliminate the commercial success of any products we may commercialize.*

*We rely on third parties to conduct our preclinical studies and our clinical trials and to store and distribute our products for the clinical trials we conduct. If these third parties do not perform as contractually required or expected, we may not be able to obtain regulatory approval for our product candidates, or we may be delayed in doing so.*

*The biopharmaceutical industry is subject to significant regulation and oversight in the United States, in addition to approval of products for sale and marketing. We may be subject, directly or indirectly, to federal and state healthcare fraud and abuse laws, transparency, health information privacy and security laws and other healthcare laws and regulations. If we are unable to comply, or have not fully complied, with such laws, we could face substantial penalties.*

*Changes in health care reform policies could adversely affect our business.*

*If we are unable to protect our proprietary rights or to defend against infringement claims, we may not be able to compete effectively or operate profitably.*

*If we cannot meet requirements under our license and sublicense agreements, we could lose the rights to our products, which could have a material adverse effect on our business.*

*The price of our common stock may fluctuate substantially.*

*Our 10% or more stockholders and management own a significant percentage of our stock and will be able to exercise significant influence over matters subject to stockholder approval.*

## **PART I**

*Unless the context requires otherwise, references to “Aridis,” “Company,” “we,” “us” or “our” refer to Aridis Pharmaceuticals, Inc., a Delaware corporation and its subsidiaries.*

### **Item 1. Business –**

#### **Overview**

We are a late-stage biopharmaceutical company focused on the discovery and development of targeted immunotherapy using fully human monoclonal antibodies, or mAbs, to treat life-threatening infections. mAbs represent a fundamentally new treatment approach in the infectious disease market and are designed to overcome key issues associated with current therapies, including drug resistance, short duration of response, tolerability, negative impact on the human microbiome, and lack of differentiation between treatment alternatives. Our proprietary product pipeline is comprised of fully human mAbs targeting specific pathogens associated with life-threatening bacterial and viral infections, primarily hospital-acquired pneumonia, or HAP, ventilator-associated pneumonia, or VAP, cystic fibrosis, and COVID-19. Our clinical stage product candidates have exhibited promising preclinical data and clinical data. Our lead product candidate, AR-301, targets the alpha toxin produced by gram-positive bacteria *Staphylococcus aureus*, or *S. aureus*, a

common pathogen associated with HAP and VAP. Current clinical development activities are focused on AR-301, AR-320, AR-701, and AR-501.

The majority of candidates from our product pipeline are derived by employing our differentiated antibody discovery platform called MabIgX™ and IPEX™. This platform is designed to comprehensively screen the B-cell repertoire and isolate human antibody-producing B-cells from individuals who have either successfully overcome an infection by a particular pathogen or have been vaccinated against a particular pathogen. We believe that B-cells from these patients are the ideal source of highly protective and efficacious mAbs which can be administered safely to other patients. IPEX™ complements and further extends the capabilities of MabIgX to quickly screen large number of antibody producing B-cells from patients and generation of high mAb producing mammalian production cell line at a speed not previously attainable. As a result, we can significantly reduce time for antibody discovery and manufacturing compared to conventional approaches.

Our initial clinical indication for AR-301 is for adjunctive therapeutic treatment with standard of care, or SOC, antibiotics for HAP and VAP. AR-320 is being developed as a pre-emptive treatment of mortality and morbidity associated with HAP and VAP in the intensive care units, or ICUs, remain high despite aggressive treatment with SOC antibiotics. Current SOC antibiotics used to treat HAP and VAP typically involve a combination of several broad spectrum antibiotics that are prescribed empirically at the start of treatment. The specific empirical antibiotic regimens that are prescribed vary widely among physicians, and generally results in modest clinical benefits due to a number of reasons, including the frequent mismatch of the antibiotics regimen to the etiologic agent and/or infection by an antibiotic resistant strain. Recently, rapid diagnostic tests have been introduced that allow the identification of infection-causing agents within hours. These increasingly common tests allow physicians to prescribe a more appropriate antibiotics regimen, and eventually targeted anti-infectives such as AR-301, AR-320, and AR-101 earlier in the course of infection. This evidenced-based treatment approach is designed to remove issues associated with empirical broad-spectrum antibiotics such as inappropriate antibiotic selection and promotion of antibiotic resistance. In contrast to the lack of differentiation among SOC antibiotics, mAbs are highly differentiated from SOC antibiotics in mechanism of action, pharmacokinetic and pharmacodynamic profile, and thus are well suited to complement antibiotics when used together. As an adjunctive treatment, AR-301 has the potential to improve the effectiveness of SOC antibiotics and cover antibiotic resistant *S. aureus* strains, while not competing directly with antibiotics. To emphasize the benefits of our product candidates as an adjunctive therapy, we design clinical trials based on superiority endpoints.

In July 2021, we announced an in-licensing agreement with MedImmune Limited, a wholly owned subsidiary of AstraZeneca, for the worldwide commercial rights of suvratoxumab, which is a half-life extended fully human IgG1 monoclonal antibody that targets the alpha toxin produced by *S. aureus*. This product is given the product code 'AR-320'. As with AR-301, AR-320's mode of action is independent of the antibiotic resistance profile of *S. aureus*, and it is active against infections caused by both MRSA and MSSA. Suvratoxumab and AR-301 are complementary products. Suvratoxumab's focus on preventive treatment of *S. aureus* pneumonia complements Aridis' AR-301 Phase 3 mAb program which is being developed as a therapeutic treatment of *S. aureus* pneumonia. We believe that AR-320 will be first-line treatment, first to market, first-in-class pre-emptive treatment of *S. aureus* colonized patients. The same first-line, first to market and first-in-class strategy applies to the acute treatment with the monoclonal antibody AR-301, which we believe can make us a global leader in this space.

AR-320 is being developed for pre-emptive treatment of high-risk patients under 65 years old for prevention of nosocomial pneumonia caused by *S. aureus*, which is associated with significant morbidity and mortality despite current standard of care, including antibiotics and infection control practices like ventilator-associated pneumonia (VAP) bundles. Currently, there are no treatments available for prevention or early preemptive management of patients at high-risk of developing *S. aureus* pneumonia. Suvratoxumab has the potential to address this unmet medical need by reducing the incidence of *S. aureus* pneumonia in patients at high-risk of developing the disease, e.g., mechanically ventilated patients in the intensive care unit (ICU) who are colonized with *S. aureus* in their respiratory tract.

HAP and VAP pose serious challenges in the hospital setting, as SOC antibiotics are becoming inadequate in treating infected patients. There are approximately 3,000,000 cases of pneumonia reported in the U.S. per year and approximately 628,000 annual cases of HAP and VAP caused by gram negative bacteria and MRSA (DRG, 2016). These patients are typically at high risk of mortality, which is compounded by other life-threatening co-morbidities and the rise in antibiotic resistance. Epidemiology studies estimate that the probability of death attributed to *S. aureus* ranges from 29% to 55% and for *P. aeruginosa* ranges from 24% to 76%. In addition, pneumonia infections can prolong patient stays in ICUs and the use of mechanical ventilation, creating a major economic burden on patients, hospital systems and payors. For example, ICU cost of care for a ventilated pneumonia patient is approximately \$10,000 per day in the U.S., and the duration of ICU stays are typically twice that of a non-ventilated patient (Infection Control and Hospital

Epidemiology, 2010, vol. 31, pp. 509-515). The average cost of care per pneumonia patient is approximately \$41,250 which increases 86% for HAP/VAP patients to approximately \$76,730. We estimate that our three clinical mAb candidates have an addressable market of \$25 billion and the potential to address approximately 325,000 HAP and VAP patients in the U.S.

Our proprietary pipeline is primarily focused on severe lung infections and is comprised of six wholly-owned product candidates which are highlighted below.

**Figure 1**  
*Our Product Pipeline*

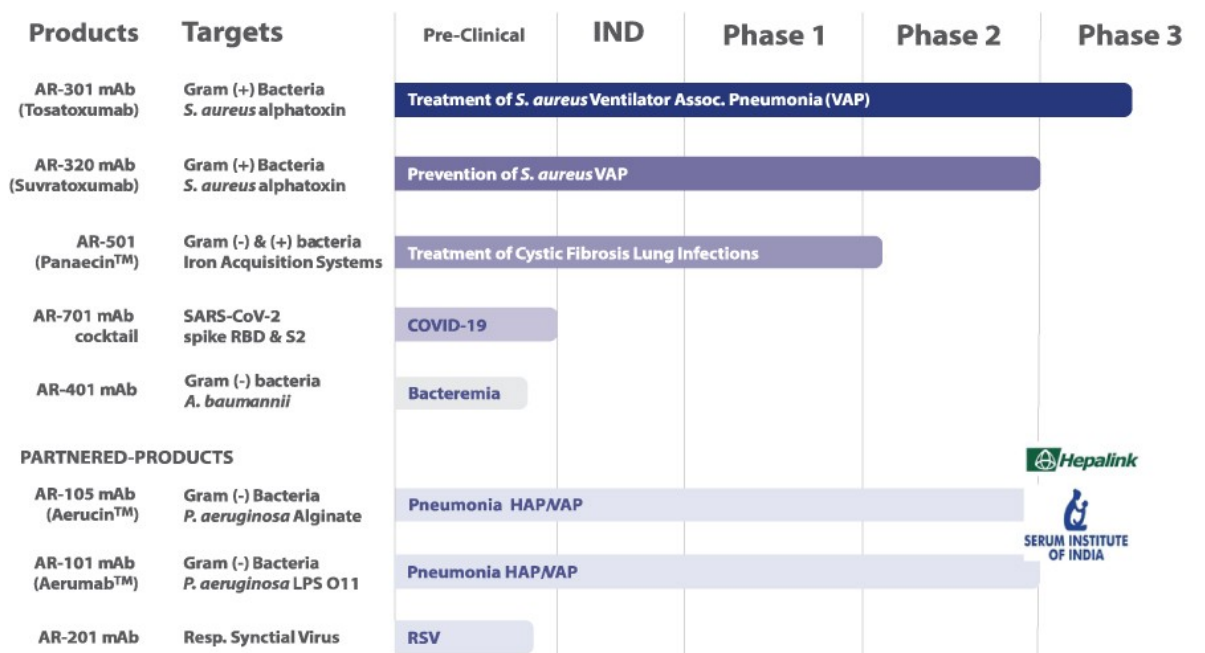

- AR-301** is a fully human immunoglobulin 1, or IgG1, mAb targeting the gram-positive bacteria *S. aureus* alpha toxin. We are developing AR-301 initially as an adjunctive immunotherapy in combination with SOC antibiotics to treat acute pneumonia caused by *S. aureus* infection. We filed an Investigational New Drug Application, or IND for AR-301 in June 2015. We completed a randomized, double-blind, placebo-controlled Phase 2a trial in 48 HAP and VAP patients. The trial met its primary endpoint of tolerability. AR-301 was generally well tolerated with no serious adverse events, or SAEs, related to the product candidate, and its pharmacokinetic properties were consistent with that of human IgG1. In addition, the trial showed trends towards benefit in various patient benefits related endpoints, including improvements in time on ventilator for VAP patients, microbiological eradication rate, time to microbiological eradication, and overall ICU and hospital stays for AR-301 plus SOC antibiotics compared to antibiotics alone. We initiated a Phase 3 pivotal trial in VAP patients in January 2019. AR-301 has been granted Fast-Track designation by the FDA, orphan drug designation in the EU, and has filed for orphan drug designation in the U.S.
- AR-320** is a fully human, IgG1 monoclonal antibody targeting *S. aureus* alpha toxin. AR-320 is active against infections caused by both MRSA and MSSA. Suvratoxumab’s focus on preventive treatment of *S. aureus* pneumonia complements Aridis’ AR-301 Phase 3 mAb program which is being developed as a therapeutic treatment of *S. aureus* pneumonia. A multinational, randomized, double blinded, placebo controlled Phase 2 study conducted by AstraZeneca (n=196 patients) showed that mechanically ventilated ICU patients colonized with *S. aureus* who are treated with suvrattoxumab saw a relative risk reduction of pneumonia by 32% in the overall intend to treat (“ITT”) study population, and by 47% in the prespecified under 65 year old population, which is the target population in the planned Phase 3 study. The relative risk

reduction in the target population reached statistical significance, and was also associated with a substantial reduction in the duration of care needed in the ICU and hospital [see [https://www.thelancet.com/journals/laninf/article/PIIS1473-3099\(20\)30995-6/fulltext](https://www.thelancet.com/journals/laninf/article/PIIS1473-3099(20)30995-6/fulltext)].

- **AR-501** (Panaecin) is a broad spectrum small molecule anti-infective we are developing in addition to our targeted mAb product candidates. This product candidate is currently in a Phase 1/2a clinical study and is funded by the Cystic Fibrosis Foundation. AR-501 is administered as an inhalable aerosol to treat lung infections in cystic fibrosis patients. Preclinical studies have shown that mice infected with *P. aeruginosa* can be rescued with a single inhalation exposure of aerosolized AR-501. We filed the IND application and subsequently initiated a Phase 1/2a trial in December 2018. The Phase 1 portion of the clinical study in healthy adults has been completed and results were reported in 2020. We have initiated a phase 2a clinical study in cystic fibrosis patients in the first half of 2021. AR-501 has been granted Fast-Track and Qualified Infectious Disease Product (QIDP) designations by the FDA.
- **AR-701** is a cocktail of fully human mAbs discovered from convalescent COVID-19 patients that are directed at multiple protein epitopes on the SARS-CoV-2 virus. It is formulated for delivery via intramuscular injection or inhalation using a nebulizer. Both mAbs in the AR-701 cocktail neutralized all authentic SARS-CoV-2 beta, gamma, delta, epsilon, and omicron variants *in vitro* and when used either individually or in combination, conferred complete eradication of virus from Omicron infected mice and protection against disease pathology.
- **AR-401** is our mAb discovery program aimed at treating infections caused by *Acinetobacter baumannii*, a gram-negative bacterium that is increasingly prevalent in blood stream, lung, and skin infections. We used our MabIgX technology to identify novel targets and select several fully human mAb candidates that bind to outer membrane proteins of the bacteria. We intend to select a development candidate for additional preclinical studies.
- **AR-101** is a fully human immunoglobulin M, or IgM, mAb targeting the gram-negative bacteria *P. aeruginosa* serotype O11. We filed an Investigational Medicinal Product Dossier, or IMPD, with the European Union (EU) in October 2004. We have completed a Phase 1 trial in healthy adults and a Phase 2a trial in 27 HAP and VAP patients. In the Phase 2a trial, AR-101 plus SOC antibiotics was generally well tolerated. The per protocol population (defined as study patients who completed the study without any major protocol deviation) demonstrated numeric improvement over standalone antibiotics across multiple clinical endpoints, including initial clinical resolution rate, time to initial clinical resolution, time on ventilator or in ICU and all-cause mortality was seen. AR-101 has been granted orphan drug designation in the U.S. and in the EU. This program is licensed to the Serum Institute of India and Hepalink.
- **AR-201** is a fully human IgG1 mAb with high affinity for respiratory syncytial virus, or RSV, glycoprotein F and neutralizes diverse clinical isolates of RSV. In *in vivo* preclinical studies, AR-201 has shown to be 12-fold more potent than Synagis in a head-to-head comparison study, a currently marketed drug for pediatric RSV. AR-201 has also been shown to bind to RSV strains that are resistant to Synagis. This program is licensed exclusively to the Serum Institute of India.

To date, we have raised over \$152 million in public and private investments. Furthermore, we have been able to augment our own financial resources by obtaining approximately \$53 million of non-dilutive awards and grants, including approximately \$32 million from the Department of Health and Human Services, or DHHS, the National Institute of Health, or NIH, and the Biomedical Advanced Research and Development Authority, or BARDA, and approximately \$12 million from the Department of Defense, Program for Appropriate Technology in Health (PATH), Gates Foundation, the Cystic Fibrosis Foundation and other strategic research and development collaborations. We believe that our ability to attract significant financial investments and grant funding underscores the recognized need for new anti-infective products and the strength of our product candidate portfolio.

We have assembled a senior management team with substantial product development experience and a successful track record of navigating complex drug development and regulatory pathways. Our management team has over 175 years of combined drug development experience from proven biopharmaceutical companies, such as Abgenix, Inc. Aviron, Genentech, Inc., GlaxoSmithKline plc, F. Hoffmann-La Roche, MedImmune (AstraZeneca), and Novartis AG among others, and has contributed to the development and launch of products with multi-billions in annual sales.



## Strategy

Our goal is to become a global leader in anti-infective immunotherapy by discovering, developing and commercializing best-in-class mAbs with the potential to significantly improve upon SOC treatments for life-threatening infections. Key elements of our strategy are as follows:

- **Leverage the favorable regulatory environment in infection diseases to expedite approval pathways for our product candidates.** We intend to closely interact with the FDA, the European Medicines Agency, or the EMA, and other regulatory agencies to create efficient clinical development plans and expedite approval pathways for our product candidates. For development outside of the U.S., we will evaluate potential regional collaborations which may lead to more rapid and cost-effective path to market compared to a standalone strategy. Consistent with this strategy, we completed a licensing agreement with Serum AMR Products, an affiliate of Serum International BV (SIBV) and the Serum Institute of India, Ltd. The agreement grants Serum AMR a license to multiple programs from us for certain limited territories and access our MabIgX® platform technology for asset identification and selection. As with our prior out-licensing transaction involving several of our mAb programs to Shenzhen Hepalink Pharmaceuticals for the China territory, this transaction allows for the introduction of innovative anti-infective therapies that are effective against antibiotic resistant infections to a broader area of the world where antimicrobial resistance is particularly high.
- **Obtain favorable regulatory designations that will fast track our product candidates.** Regulatory designations can provide numerous benefits for our product candidates, including expedited development pathway and review, market exclusivity, premium pricing and faster product adoption among others. We plan to obtain QIDP, Fast-track, and Breakthrough Therapy designations for our existing and future product candidates to enhance their likelihood of approval and commercial success. To date, we have successfully received Fast Track Designation for AR-301, AR-320, and AR-105, orphan drug designation in the U.S. for AR-101 and orphan drug designation in the EU for AR-301 and AR-101. We have obtained QIDP, and Fast-track designations for AR-501.
- **Demonstrate pharmacoeconomic benefits of our product candidates.** We aim to change the treatment paradigm of infectious disease by focusing on the pharmacoeconomic benefits of our product candidates. We utilize superiority clinical trial designs rather than non-inferiority designs typically used by antibiotics, as positive outcomes from such trials can better demonstrate efficacy and safety advantages of our product candidates. We target indications where our product candidates may address drivers of high cost of care in hospital settings, such as time on ventilator, ICU stay and hospital stay. In addition, we will continue to invest resources in market research to better identify and quantify pharmacoeconomic benefits of our product candidates.
- **Implement a targeted commercialization strategy.** Our core therapeutic indications can be addressed with a relatively small, specialized sales organization. As such, we may develop and operate our own dedicated sales force to directly market our products in the U.S., to hospitals. For geographies outside of the U.S., we may seek commercial partners with more regional expertise to maximize the commercial value of our products.
- **Employ the advantages of our IPEX and MabIgX antibody discovery platforms as a basis to expand our product pipeline.** We believe our IPEX and MabIgX platforms offer us distinct advantages over our peers in terms of new product candidate discovery and development. We can screen and identify functionally optimized B-cells from patients, and manufacture mAbs, faster than traditional technologies. Our differentiated approach reduces mAb discovery and manufacturing time compared to traditional technologies. We believe that using our technology, clinical drug supplies can be manufactured within one year from screening the patient's blood. We intend to continue to use our platform technologies to generate new product candidates for bacterial, viral, and other infectious diseases where mAb immunotherapy has the potential to address deficiencies of current treatment alternatives.
- **Continue to pursue grant funding and strategic collaborations.** To date, we have been awarded more than \$53 million in non-dilutive grant funding. We believe that the industry's need for novel products, such as our product candidates, makes non-dilutive funding from governmental agencies and research organizations more accessible. Furthermore, our robust pipeline of wholly-owned product candidates and highly productive discovery platform offer opportunities for value-accretive partnerships. We will continue to pursue grant funding and strategic collaborations in addition to traditional financings.

## Market Opportunities

Our mission is to improve the treatment of infectious diseases, particularly the deficiencies of conventional antibiotics. It is widely recognized that there is a growing problem of antibiotic resistance at a time when the pipeline of antibiotics is dwindling and much of the development activity currently ongoing is devoted to modifications of existing classes of antibiotics. We believe this antibiotic strategy has merely delayed rather than solved the underlying resistance problem as evidenced by the spread of drug resistant bacteria, particularly in the hospital settings. The drug resistance and adverse impact on the human microbiome, particularly the gut microbial flora, brought about by frequent use of broad spectrum antibiotics increased the need for targeted, narrow spectrum anti-infectives that counteract only the etiologic bacterial agent. The ability to identify the infection-causing agent has significantly improved in recent years because of the availability and proliferation of rapid diagnostic tests. These diagnostics have enabled the identification of pathogen profiles within hours of patient sample collection, thus providing physicians with the rapid, precise information necessary to make more informed treatment decisions. Given the identity of the specific pathogen responsible for an infection, we believe the physician is more likely to prescribe a targeted anti-infective, rather than a broad-spectrum antibiotic. Therefore, we believe that the treatment of infectious diseases will see a paradigm shift from broad spectrum antibiotic utilization to narrow, targeted anti-infectives. Such paradigm shift is similar to that observed in oncology starting in the early 2000s, from broad acting chemotherapies to targeted immune-oncology mAbs. Therefore, we believe that the opportunity for application of mAbs in infectious diseases is highly attractive.

The current small molecule antibiotics market is crowded, highly competitive, and lacking in product differentiation. The lack of antibiotic product differentiation is traced to the usage of non-inferiority clinical trial designs that is common practice for most of the antibiotics that have been marketed to date. No new class of antibiotic has been introduced to the market within the last two decades, which further heightens the need for new anti-infectives. In addition to significant market differentiation, mAbs may offer substantially less market competition, and higher barrier to entry. Unlike antibiotics, mAbs have a more predictable and attractive safety profile and are designed to kill via an immunological mechanism of action that is different from the mechanisms of action of all antibiotics and mechanisms of antibiotic resistance. Therefore, so long as it binds to such bacteria or their toxins, mAbs are likely unaffected by the rise in antibiotic resistant bacteria and will remain effective against antibiotic resistant bacteria. mAbs also have a dosing frequency of once or twice a month and may require only a single administration for treatment of hospital acquired pneumonia. Our mAbs will be used as an adjunct therapy in combination with antibiotics, so they will not directly compete with antibiotics. By improving the outcome in terms of mortality and reducing the time to clinical cure and length of hospital and ICU stay, mAbs offer both a medical benefit to the patient and an economic benefit to the hospital. Our clinical study designs utilize superiority in primary end points, which will allow for clear demonstration of measurable clinical benefits and product differentiation.

We are initially focused on respiratory infections in the ICU settings, particularly bacterial pneumonia. In the U.S., there are approximately 628,000 cases of HAP and VAP (DRG 2016). HAP due to methicillin-resistant *Staphylococcus aureus*, or MRSA, infections results in substantial loss of life with an annual worldwide incidence of approximately 200,000 patients (Decision Resources, 2016 data) and mortality rates as high as 50% depending on the patient population and treatment regimen (Methicillin-Resistant *Staphylococcus Aureus*, Decision Resources, 2016). Mechanical Ventilation for VAP patients costs over \$30 billion annually in the U.S. Infections due to MRSA represent a high-value segment of the overall antibiotics market. According to this report, the worldwide market for existing therapies for MRSA infections was over \$800 million in 2015. The progressively aging population is expected to increase the number of MRSA infections that result in HAP. Moreover, MRSA infections are associated with significantly longer hospital stays, repeated hospitalizations and increased healthcare costs. Currently, the median hospital stay of a patient with VAP is 29 days, and the average length of ICU stay is 19 days. The median total hospitalization costs for a VAP patient is approximately \$198,000. Current SOC antibiotics for MRSA pneumonia is dominated by five antibiotics: Linezolid, Daptomycin, Vancomycin, Ceftriaxone and Tigecycline, which combined have approximately 90% market share. There is a significant need for new anti-MRSA agents given the *S. aureus* resistance rate of 31% to 53%. We believe that the addition of AR-301 to SOC antibiotics has the potential to improve clinical outcome and could be effective in patients with MRSA infections.

**Figure 2**  
*Potential Addressable Patient Population of our mAbs AR-301 and AR-320*

	<b>AR-301 Potential Addressable Patient Population</b>	<b>AR-320 Potential Addressable Patient Population</b>
	<b>HAP/VAP (approximately)</b>	<b>(approximately)</b>
<b>US</b>	251,600	280,000
<b>EU</b>	53,750	157,000
<b>Japan</b>	90,000	102,000

#### *Cystic Fibrosis with Pseudomonas aeruginosa Infection*

There are more than 70,000 patients with cystic fibrosis worldwide. 80% of these patients present with chronic polymicrobial infections, particularly *P. aeruginosa* infection. We believe the medical need and market potential for an anti-infective therapeutic that can be given to cystic fibrosis patients chronically is substantial. The current market for inhaled antimicrobials for cystic fibrosis, based on recent combined sales figures for TOBI (tobramycin) and Cayston (aztreonam), is approximately \$600 million worldwide. Existing therapies such as aminoglycoside antibiotics lead to a temporary improvement in bacterial load, but ultimately 80% to 95% of cystic fibrosis patients succumb to respiratory failure due to chronic *P. aeruginosa* infection and airway inflammation. *P. aeruginosa* is the most significant pathogen, with the majority of cystic fibrosis patients becoming chronically infected by the age of 18 years.

#### *COVID-19 pandemic*

The ongoing pandemic of coronavirus disease 2019 (COVID-19) is caused by severe acute respiratory syndrome coronavirus 2 (SARS-CoV-2). Worldwide as of February 2022, more than 431 million cases have been confirmed, with more than 5.93 million deaths attributed to COVID-19. Symptoms of COVID-19 are highly variable, ranging from none to life-threatening illness. The virus spreads mainly through the air when people are near each other. Infection generally lasts for up to two weeks and transmission from an infected person occurs as they breathe, cough, sneeze, or speak. There are several highly efficacious vaccines that are marketed in different regions of the world. Regarding antiviral treatment, two monoclonal antibody-based therapies are available in the US, indicated for early use in cases thought to be at high risk of progression to severe disease. The antiviral remdesivir is also available as another treatment option. However, it is not recommended for people needing mechanical ventilation, and is discouraged altogether by the World Health Organization (WHO) due to limited evidence of its efficacy. Vaccination campaigns are being implemented across the world, with the expectation that it will require one to two years from now to reach the peak coverage of COVID-19 vaccination worldwide. At peak vaccination coverage, surveys have shown that at least a third of the world's population will remain unvaccinated and an additional approximately 10% or greater of the population who are vaccinated will not be adequately protected. Because SARS-CoV-2 is expected to remain endemic for years to come, the above population remains at-risk of contracting COVID-19. Currently, approximately 80 million cases of COVID-19 infection and 950,000 deaths occurred in the U.S. The COVID vaccination coverage is approximately 65%, with only 28% of the U.S. population having received a booster shot. Given the dominance of the Omicron BA.1 and BA.2 variants, having rendered vaccines and mAbs less effective or ineffective, and the low vaccine booster coverage, the majority of the US population remains vulnerable to COVID-19 infection. Therefore, there is a substantial addressable patient population who will be in need of effective therapeutic intervention.

#### **Our Product Candidates**

mAbs represent a fundamentally new immunologic approach for treating bacterial infections that can potentially overcome the problems of toxicity and resistance that may occur with traditional antibiotics when they are used long-term in individual patients and pervasively across patient populations. Our product portfolio consists of candidates that have novel mechanisms of action differing from that of traditional antibiotics and includes five mAb programs, most of which were discovered using our MabIgX platform technology, and one broad spectrum small molecule anti-infective.

## AR-301

Our lead product candidate, AR-301 is a fully human mAb of IgG1, for the treatment of lung infections resulting from *S. aureus* including MRSA strains. We are developing AR-301 as an adjunctive therapy with SOC antibiotics to treat HAP and VAP, which is in contrast to other mAb programs currently under development for prevention of HAP and VAP. AR-301 was discovered by screening the B-cell immune response repertoire generated against *S. aureus* infection. It has received Fast-Track designation in the U.S., Orphan status in the EU and has advanced into a Phase 3 pivotal trial.

A Phase 2a clinical trial was conducted to evaluate AR-301 plus SOC antibiotics compared to SOC antibiotics alone to treat HAP and VAP caused by *S. aureus*. AR-301 is targeted against *S. aureus* alpha toxin, which is a toxin produced by most *S. aureus* strains to cause destruction of human cells and tissues. In mouse models AR-301 is effective against *S. aureus* infections whether or not the bacteria are resistant to conventional antibiotics. We believe AR-301 has the potential to positively impact the outcome of *S. aureus* infections in patients by improving survival rates and/or shortening the duration of overall hospital stays, the length of time a patient requires mechanical ventilation, and/or the time a patient spends in the ICU.

We initiated the first of two Phase 3 pivotal trials in VAP patients in January 2019, which is currently ongoing. We expect to announce top line results from this trial in the second half of 2022.

### Background and Mechanism of Action

AR-301 was discovered by screening B-cell lymphocytes from a patient with a confirmed *S. aureus* infection. AR-301 binds to alpha toxin with high affinity and prevents its assembly into an active complex, which prevents alpha toxin-mediated breakdown of cell membranes, or lysis, of erythrocytes, human lung cells and immune cells such as lymphocytes (see Figure 3 below). This prevention of killing of host cells, in turn, may protect the patient from further progression of pneumonia disease and systemic infections caused by *S. aureus*. During infection and active proliferation, *S. aureus* is metabolically more virulent, geared toward higher toxin production than during its more sessile colonization stage. In contrast to other programs targeting *S. aureus* colonization, AR-301 targets the active, disease causing infection stage. There is no commercially available product that specifically neutralizes the pathogenic effects brought about by *S. aureus* toxins. We believe that this mechanism of action complements the bacterial killing properties of many conventional antibiotics, essentially neutralizing the bacterial toxins left behind following antibiotic-mediated killing. Additional indications for AR-301 may include any *S. aureus* infection, particularly surgical site infections, blood stream infections, endocarditis, and skin and soft tissue infections such as diabetic ulcers and non-healing wounds.

**Figure 3**

*AR-301's Mechanism of Action*

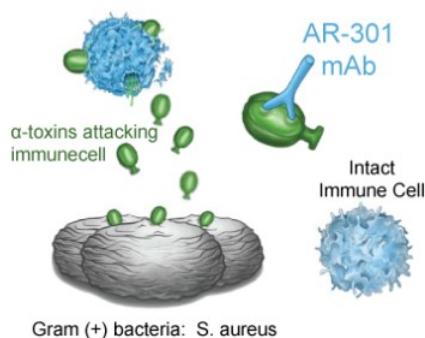

### Clinical Development Summary.

We completed a randomized, double-blind, placebo-controlled, active comparator, ascending dose Phase 2a clinical trial to assess the safety, tolerability, pharmacokinetics, efficacy and pharmacodynamics of a single intravenous administration of AR-301 plus SOC in patients with severe pneumonia caused by *S. aureus* (Francois, B. *et al.*, 2018. Intensive Care Medicine journal, *in-press*). The

SOC regimens were the physicians' choice and were based on the individual clinical site's prescribing practice. Forty-eight patients were enrolled in the study. Six patients enrolled in the first cohort (1 mg/kg AR-301 plus SOC), eight in the second cohort (3 mg/kg AR-301 plus SOC), ten in the third cohort (10 mg/kg AR-301 plus SOC) and eight in the fourth cohort (20 mg/kg AR-301 plus SOC). An additional 16 patients received placebo plus SOC as an active control. This Phase 2a clinical trial included 31 sites located across Belgium, France, Spain, the United Kingdom, and the U.S. and was designed primarily to address the safety and pharmacokinetics of AR-301. The drug was generally well tolerated. In exploratory analysis of the VAP subgroup of 25 patients, numeric clinical improvement of antibody treated patients over placebo were observed in time to extubation. Additionally, patients treated with AR-301 exhibited trends toward a higher rate of microbiological eradication, and reduction in number of hospital or ICU days.

*Phase 2a Safety and Pharmacokinetics.*

Data from the Phase 2a clinical trial suggest that AR-301 was well tolerated as a treatment for severe pneumonia due to *S. aureus* when used as directed and in addition to antibiotics. Few (2.8%) adverse events, or AEs, and no SAEs were deemed related to AR-301 treatment. A total of 36 SAEs were observed, which are listed as follows: septic shock (3 patients or approximately 6.3% of patients), anaemia (3 patients), bacteraemia (2 patients or approximately 4.2% of patients), sepsis (2 patients), acute respiratory failure (2 patients), hypoxia (2 patients), pancreatic abscess (1 patient or approximately 2.1% of patients), pneumonia (1 patient), carbon dioxide increase (1 patient), gamma-glutamyltransferase increase (1 patient), platelet count increase (1 patient), abnormal prothrombin level (1 patient), duodenal ulcer (1 patient), epistaxis (1 patient), hypoventilation (1 patient), pleurisy (1 patient), pulmonary embolism (1 patient), haemodynamic instability (1 patient), hypotension (1 patient), shock haemorrhagic (1 patient), superior vena cava syndrome (1 patient), vena cava thrombosis (1 patient), cardiac arrest (1 patient), coronary artery stenosis (1 patient), ventricular tachycardia (1 patient), multi-organ failure (1 patient), pyrexia (1 patient), hepatic failure (1 patient), hepatocellular injury (1 patient), hypoalbuminaemia (1 patient), malnutrition (1 patient), heparin-induced thrombocytopenia (1 patient), coma (1 patient), peripheral motor neuropathy (1 patient), renal failure acute (1 patient), renal failure chronic (1 patient), renal tubular necrosis (1 patient), post procedural haemorrhage (1 patient) and subdural haematoma (1 patient). Immunogenicity was observed in one subject, with no related adverse event. No significant difference in mortality was observed between groups. There were six deaths in the trial, none of which were deemed related to AR-301. Furthermore, the overall mortality observed (8.5%) in this small sample size study was very low when compared to historic published references. The pharmacokinetic, or PK, profile of AR-301 is consistent with that of a human IgG1mAb, with a plasma half-life of 23 to 31 days and supports a single-dose administration for the pneumonia indication (Figure 4).

**Figure 4**  
*Pharmacokinetics Profile of AR-301*

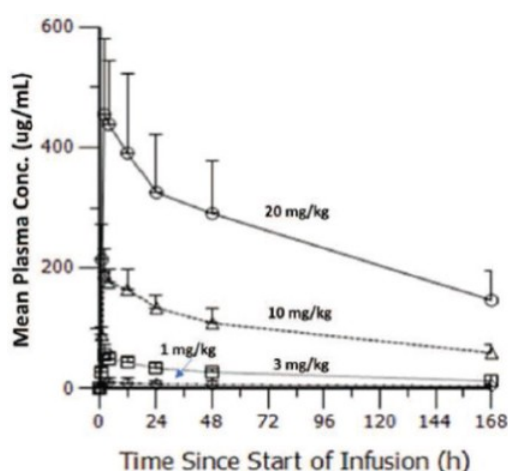

*Phase 2a Clinical Efficacy.*

We assessed multiple endpoints of clinical improvement including time to extubation. Time intubated to day 28 showed a decrease in the length of time patients who were treated with AR-301 plus SOC remained intubated as compared to those receiving

placebo and SOC. When the subset of 25 patients with VAP was assessed, a Kaplan-Meier analysis of time to extubation showed a separation of the group of patients treated with AR-301 plus SOC as compared to those treated with placebo plus SOC (see Figure 5). In the same subgroup of VAP patients, ventilation time was reduced numerically for patients in all four active dose groups receiving AR-301 plus SOC compared to those receiving placebo plus SOC. In an exploratory analysis, with all four treated cohorts pooled and compared versus the placebo cohort, statistical significance was achieved at  $p < 0.01$ . The lack of dose response could be attributed to high variability associated with a small sample size, and/or to the high level of circulating AR-301 mAb as compared to alphatoxin load in infected patients, i.e. even at the lowest dose administered (i.e. one mg/kg) it is estimated that there is more than ten-fold mAbs than the predicted alphatoxin load.

**Figure 5**

*Impact Adjunctive AR-301 Treatment on Mechanical Ventilation Time (VAP subgroup)*

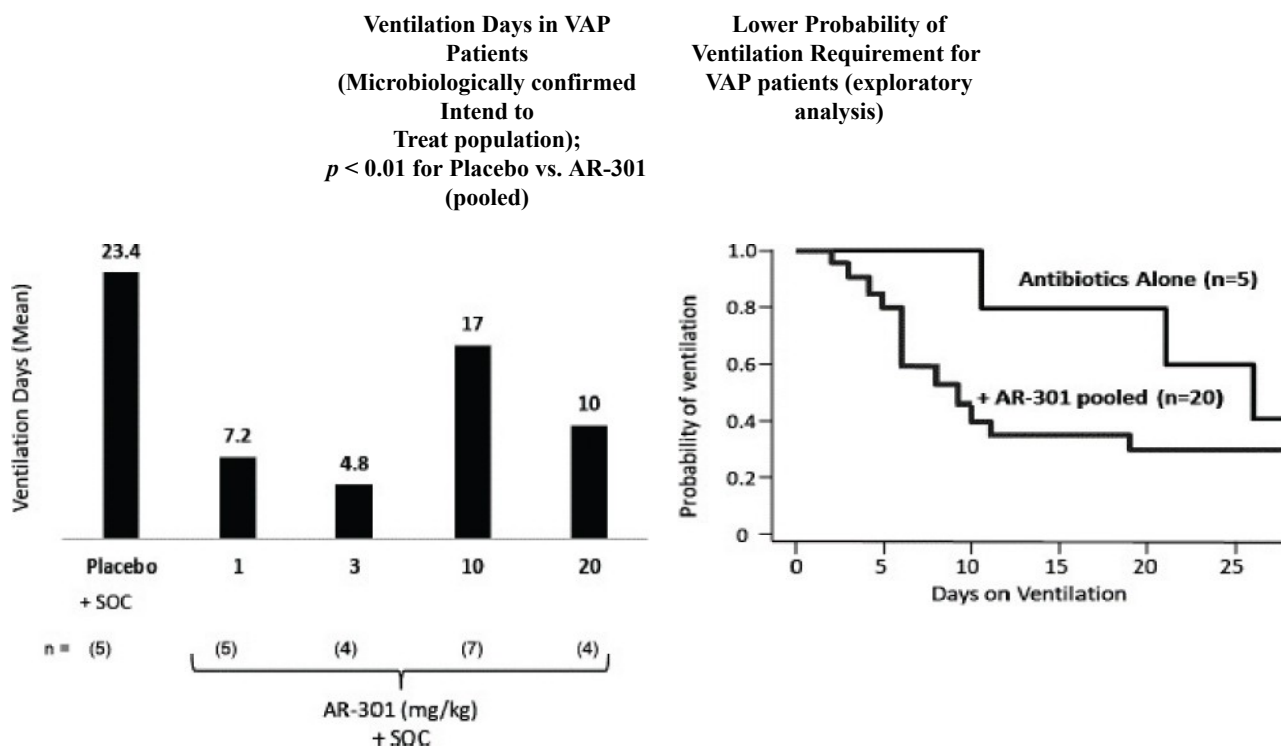

We also determined microbiological outcomes in the overall study population. Eradication or presumed eradication (cured of pneumonia) was observed in 25 (78.1%) patients treated with AR-301 plus SOC and ten (62.5%) of 16 subjects treated with placebo plus SOC. Details of microbiological outcome by treatment cohort are provided in Figure 6a and the mean time to eradication of *S. aureus* bacteria also trended shorter in AR-301 treated cohorts as compared to the Placebo cohort (Figure 6b)

**Figure 6a**

*Summary of Microbiological Outcome by Dose Level*

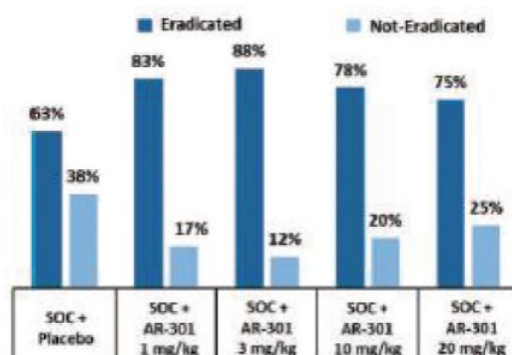

**Figure 6b**

*Mean Time to Microbiological Eradication*

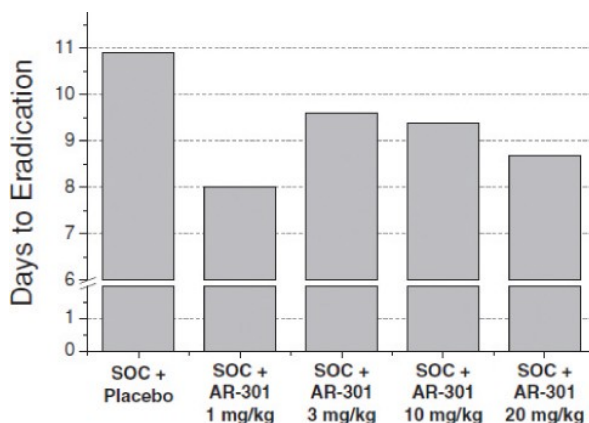

When clinical cure was assessed based on the sole judgment of the investigator, there was no statistically significant difference between the groups, and the overall cure rate was high compared to historic published references. Over the first 28 days of the study, the length of stay in the ICU and in the hospital, both showed a modest decrease in the AR-301 plus SOC groups as compared to placebo plus SOC-treated subjects, however, this difference did not reach statistical significance.

Although SOC antibiotics were effective, the results suggest that the addition of AR-301 to SOC treatment may increase the rate of microbiological eradication, and may reduce time to eradication, time under mechanical ventilation and overall duration of hospital stay. Time ventilated in the pooled AR-301 treated cohorts (n=20) showed an exploratory  $p < 0.01$  reduction in the subset of patients with VAP as compared to the placebo plus SOC cohort (n=5). A manuscript summarizing this clinical study has been published in a peer-reviewed journal Intensive Care Medicine (Francois, B., et al. 'Safety and tolerability of a single administration of AR-301, a human monoclonal antibody, in ICU patients with severe pneumonia caused by Staphylococcus aureus: first-in-human trial' Intensive Care Medicine. 44(11):1787-1796).

### *Planned Development Activities*

We plan to conduct two pivotal clinical trials in pneumonia patients for regulatory approval in the U.S. and Europe. We had an end of Phase 2 meeting with the FDA in June 2017 on the two proposed primary efficacy endpoints, ventilation time and clinical cure, for these two Phase 3 clinical trials. We also submitted a briefing document and received feedback from the EMA's Scientific Advice experts in January 2018. We have reached concurrence with the FDA on a consolidated single primary endpoint, which may include the components of mortality, ventilation requirements and signs and symptoms of pneumonia and presented these to the EMA. Per discussions with clinical experts in the field, approximately a 15% or more improvement of AR-301 plus SOC over placebo plus SOC on these efficacy outcomes is deemed to be clinically meaningful. The first Phase 3 clinical trial is a randomized, double-blind, placebo-controlled active comparator AR-301 (20 mg/kg) plus SOC versus placebo plus SOC. Subject to the extent of COVID-19 related ICU utilization, we plan to enroll up to 240 VAP microbiologically evaluable patients at approximately 130 clinical sites in over 20 countries. Assuming a treatment effect of clinical cure of 85% versus 65% in active drug treated patients would provide 90% power to demonstrate a statistically significant result. We also reached agreement with the FDA on the size of the safety database required for approval and we plan to include the following safety endpoints: immunogenicity, adverse events, and standard safety laboratory tests. We enrolled the first subject in the first quarter of 2019. The protracted COVID-19 pandemic has continued to cause an impact on patient enrollment globally and the rate of clinical site activation, as has the 2022 war between Russia and Ukraine. Pending the COVID-19 vaccination coverage, resolution of the pandemic and Russia/Ukraine war, we provisionally expect to report top-line data in the second half of 2022.

#### **AR-320**

AR-320 or 'suvratoxumab' is a human immunoglobulin G1 kappa (IgG1k) monoclonal antibody (mAb) with an extended half-life that binds alpha-toxin (AT) with high affinity and effectively blocks AT pore formation in target cell membranes. AR-320 shares similar mechanism of action as AR-301. The nonclinical pharmacologic program for suvratoxumab includes studies evaluating the ability of suvratoxumab to bind and neutralize AT and determining the frequency of AT expression in *S. aureus* clinical isolates. Suvratoxumab binds AT with high affinity and effectively blocks AT pore formation in target cell membranes. The AT gene was present in 99% and expressed by 83% of approximately 1,200 clinical isolates tested. Suvratoxumab effectively neutralizes all AT sequence variants identified in these clinical isolates indicating its epitope is highly conserved. In vitro, MEDI4893 inhibits AT mediated rabbit red blood cell (RBC) and human lung epithelial, monocytic and keratinocyte cell line lysis.

Pharmacology studies were performed using the non-YTE (i.e., non half-life extended) version of suvratoxumab (known as LC10) because YTE mutations increase antibody half-life and exposure in mice, preventing the use of suvratoxumab directly in murine models. Other than the YTE modification in suvratoxumab, the sequences of suvratoxumab and LC10 are identical.

Prophylaxis with LC10 reduced disease severity in 3 murine infection models (dermonecrosis, pneumonia, and lethal bacteraemia/sepsis) and in rabbit and ferret pneumonia models. In the lethal *S. aureus* pneumonia model, LC10 significantly improved survival, preserved lung integrity, and reduced both bacterial load in lungs and bacterial dissemination to the kidneys. Efficacy of LC10 was demonstrated, both for prophylaxis and adjunctive treatment utilizing the lethal *S. aureus* murine pneumonia model, in both immunocompetent (Hua et al, 2014) and immunocompromised (Hua et al, 2015) mice. The LC10 serum EC90 in the murine pneumonia model was 211 µg/mL, and this value was set as the clinical target level for suvratoxumab in patients. LC10 also reduced lesion size and improved survival in the murine dermonecrosis and lethal bacteraemia/sepsis models.

The nonclinical safety evaluation program for suvratoxumab included a tissue cross-reactivity study and a single-dose toxicity study in cynomolgus monkeys. As predicted for a bacterial target, no specific staining with suvratoxumab was observed using a full panel of normal human tissues in the cross-reactivity study, indicating an absence of cross-reactivity of suvratoxumab with the tested human tissues. Following a single IV infusion, suvratoxumab was well tolerated in cynomolgus monkeys at dosages exceeding the expected human therapeutic dosage. No mortality was observed in the study and during the 12-week observation period there were no adverse suvratoxumab related findings.

Toxicokinetic (TK) analyses confirmed all monkeys were exposed to suvratoxumab and revealed the expected extended half-life of this molecule. An ex vivo AT-neutralization assay demonstrated pharmacodynamic activity of suvratoxumab in serum samples from monkeys administered suvratoxumab confirming that pharmacologically active concentrations of suvratoxumab were attained. As suvratoxumab is a mAb that binds to a bacterial target not expressed in healthy humans or healthy animals, no additional toxicology studies (including reproductive toxicity studies) are planned for suvratoxumab in accordance with International Council for Harmonisation (ICH) S6(R1) guidance for Preclinical Safety Evaluation of Biotechnology-Derived Pharmaceuticals.



## Clinical Development

The clinical development of suvratoxumab is aimed to support the target indication of prevention of nosocomial pneumonia caused by *S. aureus* is a pre-emptive approach, evaluating the effects of suvratoxumab in hospitalized patients with confirmed *S. aureus* colonisation of the lower respiratory tract.

Suvratoxumab has been evaluated in two clinical studies, including a Phase 1 study in healthy adult volunteers and a Phase 2 study in mechanically ventilated patients at high risk for *S. aureus* infections. A single Phase 3 study is being proposed to support the Marketing Authorization of suvratoxumab.

Study CD-ID-MEDI4893-1133 was a Phase 1 randomised, double-blind, placebo-controlled, dose-escalation study to evaluate the safety and tolerability of suvratoxumab, administered as a single IV dose of 225, 750, 2250, or 5000 mg, compared to placebo in 33 healthy adult volunteers. Suvratoxumab exhibited linear and dose proportional serum pharmacokinetics (PK), with a half-life ( $t_{1/2}$ ) of 80-112 days, and no major safety findings were observed. PK analyses and simulations from this study served as the basis for advancing 2 dosages (2000 mg and 5000 mg) into Study CD-ID-MEDI4893-1139. The 2000 mg dose was selected as the likely efficacious dose because it was the lowest dose expected to maintain a serum AR-320 exposure above 211 µg/mL for 30 days. The 5000 mg suvratoxumab dose was selected to explore maximal efficacy in patients, and to ensure appropriate drug exposure in case there was significantly greater drug clearance in the mechanically ventilated ICU patients compared with the healthy volunteers, which would lead to the 2000 mg dose providing suboptimal exposure.

Study CD-ID-MEDI4893-1139 was a Phase 2, randomised, double-blind, placebo-controlled, single-dose, superiority design study evaluating the efficacy and safety of 2 dosages of suvratoxumab in mechanically ventilated subjects (Francois et al, 2021). These patients were in the ICU and deemed at high risk for *S. aureus* infections and were currently free of *S. aureus*-related disease but who were colonised with *S. aureus* in the lower respiratory tract.

Study enrollment was completed on April 1, 2018, when 767 patients were screened, of whom 213 patients with confirmed *S. aureus* colonisation of the lower respiratory tract were randomly assigned to the suvratoxumab 2000 mg group (n=15), the suvratoxumab 5000 mg group (n=96), or the placebo group (n=102). The 2000 mg group was discontinued per recommendation from the trial's data monitoring committee. At 30 days after treatment, 17 (18%) of 96 patients in the suvratoxumab 5000 mg group and 26 (26%) of 100 patients in the placebo group had developed *S. aureus* pneumonia (relative risk reduction 31.9% [90% CI -7.5 to 56.8], p=0.17), as determined by an independent endpoint adjudication committee (Table 1). The incidence of treatment-emergent adverse events at 30 days were similar between the suvratoxumab 5000 mg group (87 [91%]) and the placebo group (90 [90%]). The incidence of treatment-emergent serious adverse events at 30 days were also similar between the suvratoxumab 5000 mg group (36 [38%]) and the placebo group (32 [32%]). No significant difference in the incidence of treatment-emergent adverse events between the two groups at 90 days (89 [93%] in the suvratoxumab 5000 mg group vs 92 [92%] in the placebo group) and at 190 days (93 [94%] vs 93 [93%]) was observed. Forty (40%) patients in the placebo group and 50 (52%) in the suvratoxumab 5000 mg group had a serious adverse event at 190 days. In the suvratoxumab 5000 mg group, one (1%) patient reported at least one treatment-emergent serious adverse event deemed related to treatment, two (2%) patients reported an adverse event of special interest, and two (2%) reported a new-onset chronic disease.

Pre-specified analyses (Table 1) were performed for EAC-determined *S. aureus* pneumonia (primary efficacy endpoint), as well as for the exploratory efficacy endpoints of EAC-determined all-cause pneumonia, and EAC-determined all-cause pneumonia or death.

**Table 1. Pre-Specified Subgroup Analyses for Primary Efficacy Endpoint**

Endpoint — no. of subjects (%)	Placebo (n = 100)	Suvratoxumab 5000 mg (n = 96)	RRR (90% CI)*	ARR	P-value*
EAC-determined <i>S. aureus</i> pneumonia	26 (26.0)	17 (17.7)	31.9 (-7.5 to 56.8)	8.3	0.166
EAC-determined all-cause pneumonia	30 (30.0)	20 (20.8)	30.6 (-4.9 to 54.0)	9.2	0.146
EAC-determined all-cause pneumonia or death	42 (42.0)	31 (32.3)	23.1 (-4.9 to 43.6)	9.7	0.164

ARR denotes absolute risk reduction, CI confidence interval, EAC endpoint adjudication committee; mITT modified intent-to-treat, RRR relative risk reduction, *S. aureus Staphylococcus aureus*.

\*RRR (suvratouxumab vs. placebo), 90% CI, and P value based on modified Poisson regression with robust variance.

Two prespecified analyses that were conducted were 1) a subgroup of subjects who are less than or equal to 65 years old and 2) impact on the 5 VAP bundles, which is a clinical outcome improvement assessment (i.e., elevation of the head of the bed, daily sedation vacation and readiness to extubate assessment, peptic ulcer disease prophylaxis, deep vein thrombosis prophylaxis, daily oral care with chlorhexidine). Aging is associated with immunosenescence, progressively reduced innate and adaptive immune response against infections, and a concomitant increased frequency of age-related diseases, inflammatory status and comorbidities such as neurodegenerative diseases, cancer, cardiovascular, and metabolic diseases (Crooke et al, 2019; Barbe-Tuana et al, 2020). As an anti-exotoxin, suvratouxumab does not directly mediate bacterial killing, rather, a competent host immune response is required for bacterial killing. Older patients, such as those > 65 years of age, may not have sufficient immune competency to eradicate the bacterial cells, and may derive less clinical benefits from AR-320 treatment. In the Phase 2 study, 83% of subjects >65 years of age had at least 1 comorbidity compared to 64% of subjects ≤ 65 years of age (including congestive heart failure, COPD, cerebrovascular disease, chronic liver disease, coronary artery disease, diabetes, hypertension, renal insufficiency, etc). Hypertension was the most frequently reported comorbidity, and was higher among >65 years of age (63%) vs those ≤ 65 years of age (44%). A ≤ 65 years old subgroup analysis was prespecified in a Phase 2 study. Results of the prespecified subgroup analyses of the primary endpoint are shown in Figure 1. Compared with placebo, suvratouxumab treatment was associated with a statistically significant reduction of *S. aureus* pneumonia in subjects ≤ 65 years of age (relative risk reduction [RRR] = 47.4%, 90%CI, 3.5% to 71.4%, P=0.075; Table 2) and in subjects who received all 5 VAP bundles during the course of MV, statistical significant relative risk reduction was achieved (RRR = 46.3%, 90%CI, 2.2% to 70.5%, P=0.075). Post hoc analysis also demonstrated a reduction of *S. aureus* pneumonia in suvratouxumab-treated subjects with a low *S. aureus* LRT colonisation load (RRR = 66.7%, 90%CI, 21.3% to 86.2%, P=0.069) (Figure 1).

**Figure 1. Results of Pre-Specified Subgroup Analyses**

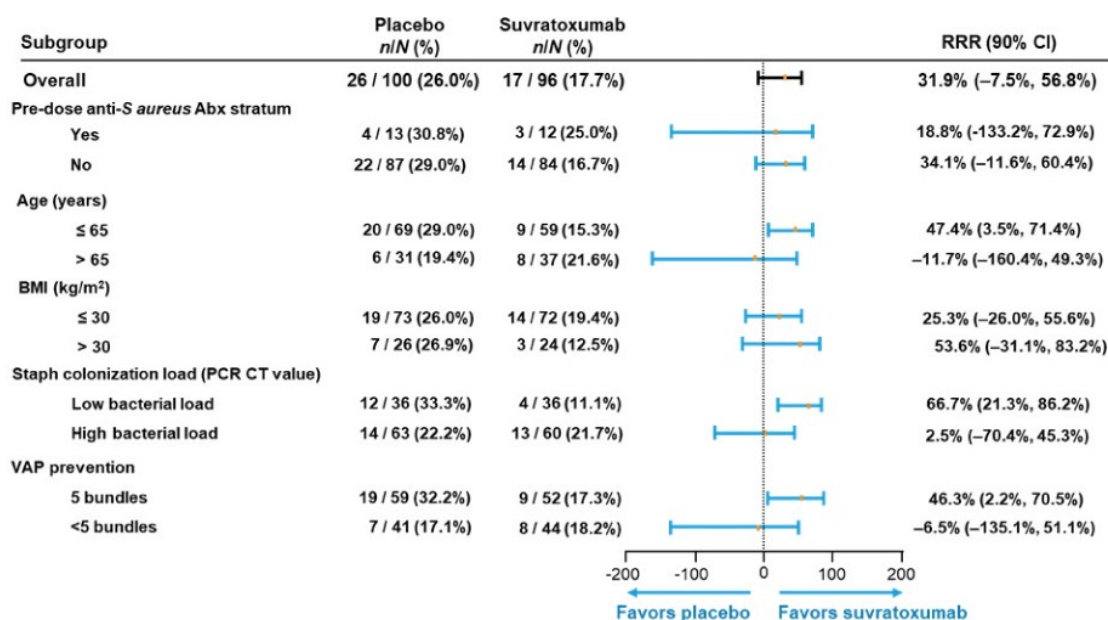

Note: Overall RRRs and 90% CI were calculated with Poisson regression with robust variance. Subgroup analyses were prespecified. Subgroup RRRs and 90% Cis were based on the unconditional CI on the ratio of proportions. Abx= antibiotics; CT= cycle threshold; RRR= relative risk reduction; VAP= ventilator-associated pneumonia. Subgroup analysis of *S. aureus* colonisation load was done as a post-hoc analysis. Preventive VAP measures (bundles) were elevation of the head of the bed, daily sedation vacations and extubation readiness assessment, peptic ulcer disease prophylaxis, deep vein thrombosis prophylaxis and daily oral care with chlorhexidine.

Efficacy analyses of the prespecified subgroup of subjects ≤ 65 years of age provided consistent magnitude of absolute risk reduction across the primary and key exploratory endpoints of EAC-determined *S. aureus* pneumonia (primary efficacy endpoint), as

well as for EAC-determined all-cause pneumonia, and EAC-determined all-cause pneumonia or death (exploratory efficacy endpoints) as shown in Table 2.

**Table 2. Efficacy Analysis on the Prespecified Subgroup of Subjects ≤ 65 years of age**

EAC-Endpoint Definition	Placebo N = 69	MEDI4893 5000 mg N = 59	Absolute Risk Reduction	Relative Risk Reduction (90% CI)	P Value	NNT
<i>S. aureus</i> Pneumonia	20 (29.0%)	9 (15.3%)	13.7%	47.4% (3.5%, 71.4%)	0.075	7.3
<i>S. aureus</i> -Only Pneumonia	5 (7.2%)	0	7.2%	100% (33.5%, 100%)	ND	13.9
All-Cause Pneumonia	22 (31.9%)	10 (16.9%)	15%	46.8% (6.3%, 69.9%)	0.055	6.7
All-Cause Pneumonia or Death	29 (42.0%)	17 (28.8%)	13.2%	31.4% (-5.4%, 55.2%)	0.131	7.6

NNT = numbers needed to treat

The duration of healthcare resource utilization analyses (Table 3 and Table 4) suggested trends in reduction of HRU in the mITT, those ≤ 65 years old. In addition, the duration of HRU were also shorter in HRU duration among subjects who developed EAC *S. aureus* pneumonia.

**Table 3. Duration of Healthcare Resource Utilization Analyses**

Health Resource	Overall Study Population			Subjects ≤65 Years of Age		
	Placebo N=100	Suvratoxumab N=96	Days Saved/ Subject	Placebo N=69	Suvratoxumab N=59	Days Saved/ Subject
<b>Hospital duration</b>						
Mean hospitalisation duration (days)	37.9	35.2	2.7	39.1	30.3	8.8
<b>ICU duration</b>						
Mean ICU duration (days)	20.5	18.5	2.0	20.0	16.7	3.3
<b>MV duration</b>						
Mean MV duration (days)	15.3	14.2	1.1	14.6	12.7	1.9
<b>Systemic Antibiotics</b>						
Mean antibiotic duration (days)	21.4	20.9	0.2	23.6	18.0	5.6

MV = mechanical ventilation

**Table 4. Duration of All Cause Healthcare Resource Utilisation Through Day 91 (mITT Population – Subjects with EAC-determined *S. aureus* Pneumonia)**

Parameter	Placebo N = 26	MEDI4893 5000 mg N = 17	Days Saved/ Subject in MEDI4893 group
Duration of hospitalisation (days)			
n	26	17	
Mean (SD)	42.2 (24.7)	33.3 (24.6)	8.9
Duration of ICU stay (days)			
n	26	17	
Mean (SD)	23.3 (17.5)	18.1 (10.3)	5.2
Duration of mechanical ventilation (days)			
n	26	17	
Mean (SD)	18.7 (16.9)	13.4(6.2)	5.3
Duration of systemic antibiotic usage (days)			
n	26	17	
Mean (SD)	23.7 (19.0)	18.8 (15.1)	4.9

EAC = Endpoint Adjudication Committee; ICU = intensive care unit; mITT = modified intent-to-treat; SD = standard deviation.

In patients in the ICU receiving mechanical ventilation with PCR-confirmed *S. aureus* colonisation of the lower respiratory tract, the incidence of *S. aureus* pneumonia at 30 days following treatment with 5000 mg suvratoxumab than with placebo. These results support that mAbs represent a promising therapeutic option to reduce antibiotic consumption that require further exploration and studies.

*Planned Development Activities*

An IND amendment is planned for the second quarter of 2022 to include the final Phase 3 protocol (AR-320-003), in addition to an updated Module 3 for the description of the drug substance and drug product lots produced at a new manufacturing facility, using the same Phase 1-2 Master Cell Bank, and same Phase 1-2 DP formulation.

Study AR-301-003 will be a Phase 3, randomised, double-blind, placebo-controlled, single-dose study to evaluate the efficacy and safety of suvratoxumab in mechanically ventilated adults ( $\leq 65$  years old) and adolescents for the prevention of nosocomial pneumonia caused by *S. aureus*. Approximately 420 subjects will be enrolled at 200 centres worldwide. Subjects will be randomly assigned in a 1:1 ratio (210:210) to receive a single IV dose of suvratoxumab (5000 mg) or placebo. Randomisation will be stratified by age group (adults vs. adolescents), country, by whether or not subjects received systemic anti-*S. aureus* systemic antibiotic treatment, and by whether the subject has underlying COVID-19 infection. Following investigational product administration on Day 1, subjects will be followed through Day 91. A schematic representation of the study design is presented in Figure 2.

**Figure 2. Study Flow Diagram and Additional Design Details**

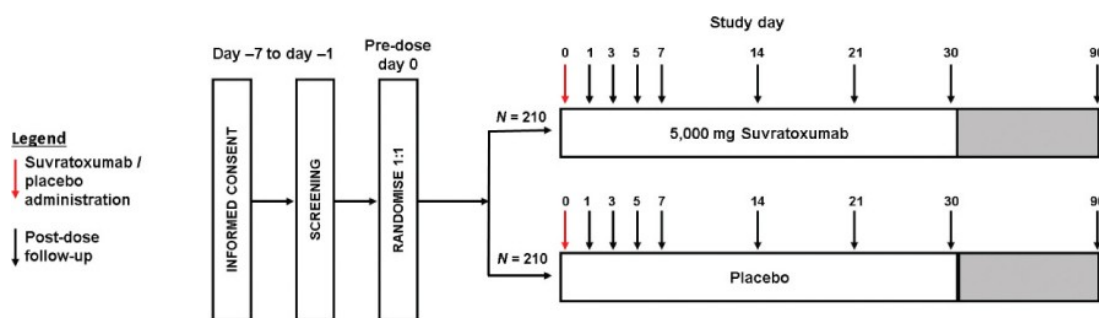

The primary endpoint for this study is the incidence of *S. aureus* pneumonia through 30 days after a single dose of suvratumab in mechanically ventilated subjects at risk for *S. aureus* pneumonia. It is anticipated that while a substantial number of mechanically ventilated subjects will continue to require mechanical ventilation throughout the 30-day post-dose period, a number of subjects will be weaned off the ventilator during this period.

Assuming successful outcomes from the proposed Phase 3 study and agency agreement to the development strategy, it is the intent that a Biologics License Application (BLA) will be submitted at the end of the clinical trial

### AR-101

AR-101 is a human IgM mAb that we are developing to treat *P. aeruginosa*, the leading cause of hospital acquired lung infections. AR-101, which we are initially developing as an adjunct therapy for the treatment of HAP and VAP caused by *P. aeruginosa* serotype O11, binds to the lipopolysaccharide, or LPS, on the cell surface of *P. aeruginosa*. Serotype O11 is one of the most prevalent *P. aeruginosa* serotypes in HAP and VAP, representing approximately 23% of cases (Lu et al 2014). It is estimated that the addressable patient population in the U.S., EU and Japan combined is approximately 95,600 patients. AR-101 has been granted orphan drug designation in the U.S. and in the EU. We intend to incorporate a companion diagnostic test based on polymerase chain reaction, or PCR, technology that can rapidly identify *P. aeruginosa* serotype O11 strains in order to identify those patients most likely to respond to AR-101. We have completed a Phase 1 safety and tolerability trial of single ascending doses of AR-101 in healthy adults and an open-label Phase 2a safety and pharmacokinetics trial of up to three single doses of AR-101 in pneumonia patients. These studies suggested AR-101 to be generally well tolerated in both healthy adults and HAP and VAP patients. Comparison of the per protocol population (n=13) of the Phase 2a study, which excluded four patients from the ITT population (n=17) because they did not complete the treatment regimen, and a contemporaneous control cohort suggested that AR-101 therapy may improve survival, cure rate of the index pneumonia, and time to cure pneumonia.

**Figure 7**  
*AR-101 Mechanism of Action*

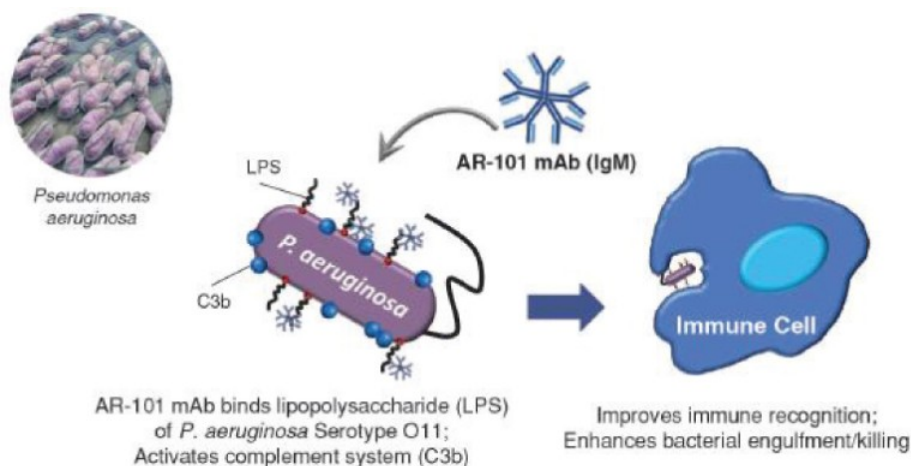

### *Background and Mechanism of Action*

Upon binding, AR-101 mediates the deposition of the human complement to the surface of *P. aeruginosa* bacteria. This antibody-complement complex leads to improved recognition by the host immune cells, which results in engulfment and killing of the bacteria (Figure 7). AR-101, like IgM antibodies in general, provides several advantages towards more effective bacterial killing. They possess ten binding sites rather than two for IgG, and they are 100 to 1,000 times more effective than IgG at binding and/or activating key enzymes that facilitate the killing of *P. aeruginosa*. As a result, IgM antibodies are becoming more prevalent as candidates for drug therapies.

### *Clinical Development Summary*

We have completed two clinical studies of AR-101 to date. We completed a Phase 1 study in healthy volunteers to assess the safety and pharmacokinetic characteristics of AR-101. This randomized, double-blind, placebo-controlled study enrolled 32 volunteers in four antibody treatment cohorts at doses of 0.1, 0.4, 1.2 and 4.0 mg/kg as well as placebo cohort. No SAEs were observed, and no subject was discontinued due to an AE. Reported AEs were mild or moderate in intensity, and all resolved without sequelae, and the incidence of AEs did not increase with the dose. There was no activation of an immune response against AR-101. Pharmacokinetic characteristics that were observed were consistent with the characteristics of a human IgM, with a serum half-life between 70 and 95 hours.

Subsequently, we completed an open-label Phase 2a study in 18 subjects, which was the first study performed in the target indication of patients with severe bacterial pneumonia caused by *P. aeruginosa* serotype O11. Treatment consisted of three intravenous infusions of 1.2 mg/kg of AR-101 given over two hours on days one, four and seven for a total dose of 3.6 mg/kg. The 30-day survival rates were 82% in the intent-to-treat (ITT; 17 subjects) and 100% in the per protocol (13 subjects) populations, respectively. Clinical resolution of pneumonia was observed in 76% of patients in the ITT population and 100% of patients in the per protocol population. Microbiological resolution was observed in six subjects, representing 35% of the ITT population and 31% of the per protocol population. The time to resolution of pneumonia was 14 days and nine days in the ITT and per protocol populations, respectively. The time to extubation or cessation of ICU management was 22 days in the ITT and 13 days in the per protocol populations, respectively. Measurements of clinical status improved promptly in parallel with clinical resolution of disease.

14 SAEs were experienced by six of the subjects. The types of SAEs were: gastrointestinal bleeding (3 patients or approximately 21% of patients), cardiac and respiratory arrest (2 patients or approximately 14% of patients), multi-organ failure (2 patients), hyperbilirubinemia and cholestasis (1 patient or approximately 7% of patients), neutropenia (1 patient), low count of platelets (1 patient), activated partial thromboplastin time (1 patient), prolongation (1 patient), septic shock (1 patient); cholestasis (1 patient) and troponin increase (due to cardiac arrest) (1 patient). An event of cardiorespiratory arrest was judged as probably related to AR-101 and events of hyperbilirubinemia and cholestasis, although pre-existent, were deemed possibly related. In both cases, the investigators assessed that a contribution by AR-101 to the adverse event could not be excluded with certainty but acknowledged other probable causes were acknowledged. The other SAEs were deemed unrelated.

In parallel, we also conducted a contemporaneous cohort study of the incidence and outcome of HAP and VAP caused by various *P. aeruginosa* serotypes in critically ill patients. The data were extracted from the medical files of the patients selected according to eligibility criteria similar to those of our Phase 2a study. Cohort patients infected with *P. aeruginosa* serotype O11 (14 patients in total) had a lower survival rate, cure rate, and microbiological resolution rate, as well as longer mean times on ventilator and in the ICU as compared to patients in our Phase 2a clinical trial who received a complete treatment of three 1.2 mg/kg doses of AR-101. A summary of the results of the Phase 2a study and the contemporaneous cohort study is shown in Figure 8 below.

**Figure 8**  
*AR-101 Phase 2 Trial Comparison of Adjunctive (AR-101 + Antibiotics) to Cohort (Antibiotics Alone) Groups*

	AR-101 + Antibiotics Intent-to-Treat (n=17)	AR-101 + Antibiotics Per Protocol (n=13)	Contemporaneous Cohort Study Serotype O11 (n=14)
Mortality (%)	18% (3/17 pts)	0% (0/13 pts)	21% (3/14 pts)
Time to Initial Clinical Resolution of Pneumonia (mean)	14 days ± 10 days SD	9 days ± 2.9 days SD	19 days ± 10 days SD
Initial Clinical Resolution of Pneumonia (%)	76% (13/17 pts)	100% (13/13 pts)	64% (9/14 pts)
Clinical Resolution of Pneumonia on Day 30	65% (11/17 pts)	85% (11/13 pts)	57% (8/14 pts)
Microbiological Resolution on Day 30	35% (6/17 pts)	31% (4/13 pts)	14% (2/14 pts)
Time on Ventilator or Time in ICU*	22 days	13 days	21 days

\* Kaplan-Meier time-to-event estimation of the times where 50% of patients had experienced the event. ‘pts’ = patients

*Preclinical Summary*

AR-101 reacts with a wide range of *P. aeruginosa* serotype O11 clinical isolates from different hospitals, indicating broad application against infections with this serotype. AR-101 is also capable of stimulating phagocytic immune cells to ingest *P. aeruginosa* bacterial cells in a dose dependent manner, thereby killing the pathogen. Passive immunization with murine mAb recognizing O-polysaccharides in LPS of *P. aeruginosa* conferred protection against lethal challenge with live pseudomonas bacteria in several animal models of pneumonia infections. In preclinical studies, AR-101 was found to demonstrate attenuating protection against pulmonary infections caused by *P. aeruginosa* serotype O11 and exhibited a complementary effect with meropenem, a broad-spectrum antibiotic. Additionally, we had the following observations in preclinical studies of AR-101. AR-101 protected mice in a dose-dependent manner from *P. aeruginosa* infection after a burn-wound challenge. Doses of five µg/mouse (corresponding to about 0.2 mg/kg body weight) conferred 70% to 100% protection from systemic *P. aeruginosa* challenge. Administration of decreasing doses resulted in lower survival rates and administration of AR-101 led to rapid clearance of *P. aeruginosa* from the lung in mice and was associated with milder lung pathology six and 24 hours after infection. In addition, AR-101-treated animals had a significantly lower systemic *P. aeruginosa* bacterial load compared to control animals that received saline. To mimic the adjunctive use of AR-101 in humans, AR-101 was administered in combination with meropenem (used clinically to treat pseudomonas infections) in a modified lung challenge model. When meropenem and AR-101 were administered in combination, significant reductions in lung weight (a surrogate marker for injection-induced inflammation), bacterial load and lung inflammation were observed in infected mice compared to each agent given alone.

**AR-501**

To complement our suite of targeted antibody product candidates, we are developing AR-501 (gallium(III) citrate) as an anti-infective therapy to manage both chronic lung infections in cystic fibrosis patients. AR-501 exhibits broad antimicrobial activity against antibiotic resistant gram-negative and gram-positive bacteria in free-living, or planktonic, and biofilm communities, as well as against non-tuberculosis mycobacteria and fungi. We believe AR-501’s unique combination of broad spectrum antimicrobial activity against pathogens, lower propensity to develop resistance than inhaled TOBI (tobramycin) and Cayston (aztreonam), and less frequent dosing as compared to SOC, make it an ideal candidate for treatment of chronic polymicrobial infections, such as lung infections in cystic fibrosis patients. AR-501 has been granted Fast-Track and QIDP designations by the FDA.

To enhance delivery to the lungs and provide a simple method of administration, we are developing AR-501 as an inhaled formulation that can be administered conveniently with one of several commercially available liquid nebulization devices. We were awarded a development grant from the Cystic Fibrosis Foundation for up to approximately \$7.5 million to develop an aerosolized formulation of AR-501 to manage bacterial lung infections in cystic fibrosis patients. We have produced, good manufacturing practice, or GMP, clinical bulk drug that is ready for use in human clinical trials, and we have completed good laboratory practice, or GLP, toxicology studies. We believe that the novel characteristics of AR-501, namely broad spectrum activity, lower propensity to develop resistance, and long half-life, may enable cystic fibrosis patients to avoid the current need for the intermittent “drug holidays” commonly employed with SOC drugs such as TOBI (tobramycin). The novel characteristics of AR-501 may also benefit patients with other infectious lung diseases such as chronic obstructive pulmonary disease, bronchiectasis, and pneumonia.

### *Background and Mechanism of Action*

AR-501 is a proprietary formulation of gallium(III) citrate. Trivalent ions of the element gallium (Ga) have biologic activity because Ga(III) chemically mimics the ferric iron ions (Fe(III)) that bacteria and many other microorganisms require for survival. Bacterial iron-binding proteins imperfectly distinguish Ga(III) from Fe(III), functionally starving bacteria of iron and poisoning critical Fe(III)-dependent metabolic pathways. We believe this novel mechanism of action is distinct from those underlying all current antibiotics.

There is a long history of administering gallium(III) salts to humans. Gallium scans are used as diagnostic tests to identify areas of inflammation, infection, or cancer in the body, and Ganite, a formulation of gallium(III) nitrate, was introduced in 2003 as an FDA-approved intravenous treatment for hypercalcemia secondary to cancer. The anti-infective activity was only recently demonstrated using gallium(III) nitrate in citrate buffer. Our *in vitro* tests and *in vivo* animal studies show that gallium(III) citrate exhibits the same antimicrobial activity as gallium(III) nitrate in citrate buffer, demonstrating that Ga(III) ion itself, and not any particular salt form, is responsible for the anti-infective activity.

### *Clinical Data Summary*

More than 50 published human clinical trials conducted in more than 1,000 cancer patients attest to the safety of systemic Ga(III) compounds and establish a tolerated dose that greatly exceeds the dose at which we project AR-501 will be used. Recently an open-label Phase 1 proof-of-concept clinical trial of Ganite administered intravenously to cystic fibrosis patients showed evidence of an improvement in lung function and reduction of *P. aeruginosa* burden in the lungs. Investigators at the University of Washington, or UW, and the Cystic Fibrosis Foundation conducted the clinical study, and we analyzed patient samples to determine pharmacokinetics. The aim of the study was to assess the pharmacokinetics, lung distribution, and safety of intravenous Ga(III) in cystic fibrosis patients. This non-randomized Phase 1 study comprised two dosing cohorts (cohort one: n=9 patients, cohort two: n=11 patients). Analysis of subjects' sputum, urine, and plasma showed persistent Ga(III) levels in sputum up to 28 days after a single dose. Encouragingly, a number of patients in both cohorts showed significant reduction in sputum *P. aeruginosa* and an improvement in steady forced expiratory volume (FEV1) throughout the 28 days. We anticipate that inhaled AR-501 can result in at least 100-fold higher Ga(III) concentration in the lungs. The UW investigators continue to develop Ganite as an intravenous treatment for cystic fibrosis associated lung infections and initiated a randomized, double-blind Phase 2 clinical study in cystic fibrosis patients. This study was completed in the second half of 2018 and provided clinical evidence of the safety and efficacy of Ga(III) in cystic fibrosis patients (see Goss, C. et al. The Ignite Study: IV Gallium Nitrate As A Treatment For Chronic Pseudomonas Aeruginosa Infection In CF. North American Cystic Fibrosis Conference Abstract number 307, 2018).

### *Preclinical Data Summary*

AR-501 exhibits antimicrobial activity in diverse *in vitro* and *in vivo* bacterial infection models. The *in vitro* activity of Ga(III) salts extends to many gram-negative and some gram-positive bacteria, non-tuberculosis mycobacteria, fungi and *in vivo* activity has been demonstrated against *P. aeruginosa* when administered via inhalation and intraperitoneal injection. We showed that persistent exposure of *P. aeruginosa* to gallium(III) citrate did not change the minimum inhibitory concentration, or MIC, whereas parallel studies demonstrated a greater than eight-fold rise in MIC for the antibiotics tobramycin, vancomycin, or aztreonam. Thus, we believe that for mechanistic reasons, bacteria are less likely to develop resistance to Ga(III) compounds than to conventional antibiotics. Pharmacokinetic studies of inhaled AR-501 in mice showed the initial half-life was 0.6 hours and the terminal half-life was 40.0 hours. In preclinical animal lung infection studies, AR-501 at an inhaled dose as low as 3.7 mg/kg is protective against a lethal challenge with *P. aeruginosa* strain PA103.

We tested the local effects of inhaled Ga(III) on lung tissues by examining the acute pulmonary toxicity of inhaled gallium(III) nitrate formulated in a citrate buffer in mice. We exposed animals to aerosolized gallium(III) nitrate formulated in a citrate buffer (12.5 mg/mL) for two, four, or six hours in a whole body exposure chamber. Histopathological evaluation revealed no significant changes in lung tissues. Inflammation was observed that reached a maximum at four to eight hours post dosing but waned beyond eight hours. Mice and subsequently dogs that were administered AR-501 by inhalation once per week for 28 days (five administrations), showed unremarkable clinical chemistry findings, and no significant adverse observations were noted in the lungs or kidneys. The no observed adverse effect level from the GLP toxicology testing has been established.



*Planned Development Activities*

The Phase 1 portion of the clinical study in healthy adults has been completed and results were reported in 2020. The Phase 2a clinical study is initiated. Pending the resolution of the on-going COVID-19 pandemic, we provisionally expect to complete enrollment in the second half of 2021 and top-line data shortly afterwards.

**AR-701**

With the substantial number of people unvaccinated and immunocompromised world-wide, and the emergence of new variants that can evade immune protection, a great need remains for new therapeutics against SARS-CoV-2 that are unlikely to be impacted by its continued evolution. Furthermore, there is a potential treatment advantage of combining Abs that simultaneously inhibit multiple viral functions. AR-701 is a cocktail of two fully human immunoglobulin G1 (IgG1) lambda mAbs AR-720 and AR-703 that inhibits both ACE2 binding and viral fusion. The cocktail directed at the SARS-CoV-2 spike (S-protein) receptor binding domain (RBD) and the stem 'S2' region, respectively. AR-701 was identified by screening the blood of COVID-19 convalescent patients. Antibodies directed to the S-protein RBD are generally thought to be required for blockage of viral binding and host cell entry via the human angiotensin converting enzyme 2 (ACE2) receptor, and thus viral neutralizing. RBD is used predominantly as the target in clinical stage vaccines and antibody candidates, with positive clinical responses, with two mAbs receiving Emergency Use Authorization (EAU) from the FDA. AR-703 recognizes all human  $\beta$ -coronavirus and neutralize SARS-CoV and MERS-CoV. It has demonstrated significant prophylactic activity in K18 hACE2 mice infected with SARS-CoV-2 Wa-1, Beta, and Omicron. AR-703 delivered as a single 4 mg/kg intranasal (i.n.) dose to hamsters 12 hours following infection with SARS-CoV-2/Delta protected them from weight loss, with therapeutic activity further enhanced when combined with AR-720, an S1-specific neutralizing mAb. As little as 2 mg/kg of AR-703 i.n. 20 hours following infection with SARS-CoV/Urbani protected hamsters from weight loss and significantly reduced upper and lower respiratory viral burden. These results indicate co-operativity between S1 and S2 specific neutralizing mAbs and that potent universal coronavirus neutralizing mAbs with therapeutic potential may be induced in humans and may inform universal coronavirus vaccine development. AR-701 showed broad binding to SARS-CoV-2 clinical isolates, including recently reported variants of SARS-CoV-2 such as the variants associated with the UK, South Africa, Brazil and Japan SARS-CoV-2, Delta, and Omicron. AR-701 also binds and neutralized SARS and MERS coronaviruses, which were viruses that caused prior pandemic in China and the Middle East, respectively.

Different from other mAb therapies that are under clinical testing, AR-701 is intended to be delivered via inhalation. COVID-19 mAb has been shown to mediate therapeutic treatment benefits and eradication of SARS-CoV-2 infected animals at a lung deposited dose level that is more than 100-fold lower than the dose required to achieve similar levels of efficacy when delivered by the parenteral route of administration (Piepenbrink, et al., Cell Reports Medicine doi: 10.1016/j.xcrm.2021.100218). AR-701 has shown evidence of treatment benefit as low as 0.6 mg/kg of inhaled dose, equivalent to 0.01mg/kg of lung deposited dose (Figure 9).

**Figure 9**

*Intraperitoneal (IP) or intranasal showed eradication of Omicron SARS-CoV-2 in the lungs of infected ACE2 mice and protection from mortality.*

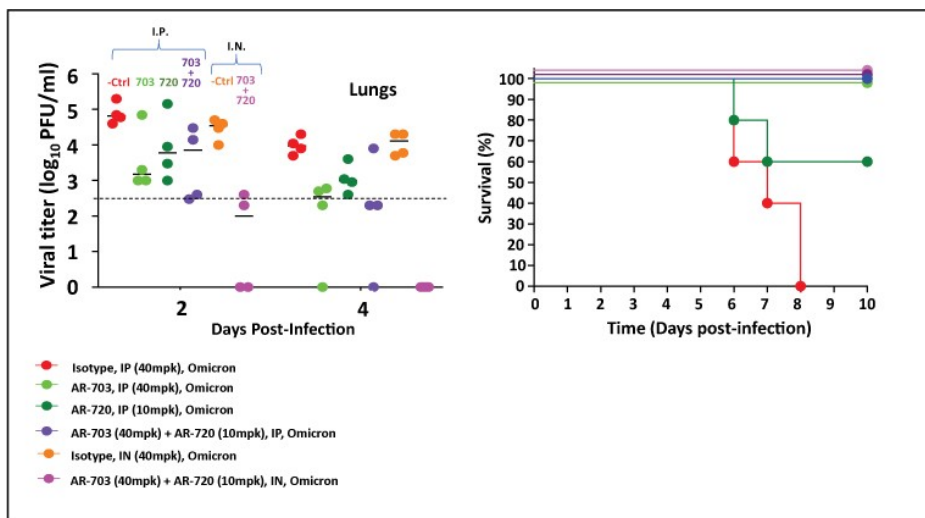

There are two key advantages of inhalation delivery of a mAb over standard IV administration. The first is dosing efficiency and dose sparing as compared to the parenteral routes of administration. With an efficient nebulization device, up to half the dose or more can be deposited in the lungs, which is the target organ. In contrast, a recent clinical study showed that when a 1800 mg mAb dose is delivered by IV, the estimated peak concentration of drug reached in the epithelial lining fluid (ELF) in the lungs (C<sub>max</sub>) was only 128 µg/mL (Magyarics, et al, 2019), which represents less than 0.2% of the drug administered (Fröhlich, et al, 2016). The benefit of significant dose sparing provided by inhalation administration will alleviate supply constraints for the drug, allowing the treatment of significantly more patients from each mAb production batch and thereby expanding the number of patients that can receive the drug. The second key advantage of inhalation delivery over parenteral delivery is convenience. Administration by inhalation does not require a hospital or clinic, and, as with many other inhaled treatments such as those for cystic fibrosis or asthma, can be performed by the patient themselves in their own home. The convenience of self-administration in an outpatient setting is designed to lower the barrier to COVID-19 treatment. This can also reduce the burden on hospital resources, reducing exposure risks to health care workers. These advantages, combined with increased supply, enables a uniquely positioned mAb treatment in much broader patient settings.

**AR-401**

AR-401 is our mAb discovery program aimed at treating infections caused by *A. baumannii*, which is a gram-negative pathogen that is rapidly emerging as a serious threat to patients in hospital care. Its high level of resistance to first-line antibiotic therapies, potential to survive prolonged periods on dry surfaces and ability to form biofilms rapidly on artificial devices, such as catheters and ventilators, have made it particularly virulent. The clinical impact of *A. baumannii* infections can have serious adverse consequences with crude mortality rates reaching 30% in infected ICU patients. Moreover, infection with *A. baumannii* leads to an increased length of stay at the ICU of an average of 15 extra days. We intend to develop an anti-*A. baumannii* human mAb to address the unmet medical need for new and effective anti-infectives to treat severe and life-threatening infections caused by this difficult-to-treat bacterium.

We have made significant progress toward the identification of potential anti-microbial targets on *A. baumannii*, which we believe will facilitate the development of both active and passive immune-based therapies. We believe our preliminary target identification work on *A. baumannii* is among the most comprehensive to date. We used a proteomic approach to identify bacterial surface proteins that are accessible to the immune system. We then performed a thorough analysis using multiple bioinformatic tools that reduced the number of identified proteins to eight outer membrane proteins on *A. baumannii*. Our studies showed that active immunization with each protein reduced mortality in a pneumonia model. Antibodies against these *A. baumannii* targets were also

detected in the majority of *A. baumannii* infected patient sera. Polyclonal rabbit immune sera raised against these targets mediated protection in the *Acinetobacter* pneumonia mouse model as shown by a reduction of mortality and clinical score.

Of the eight surface proteins identified as potential targets for mAbs, three have been previously characterized. The five remaining proteins are of unknown function, potentially representing completely unique and innovative targets. Antibody titers to all eight proteins can be detected in sera of convalescent patients whereas sera from healthy donors from a regional blood bank have only very low or undetectable antibody serum titers to these proteins. An initial study demonstrated that the peripheral blood lymphocytes, or PBL, from patients with a high serum titer can result in hybridoma cell lines that specifically stain *A. baumannii* cells. Our planned next step for this program is to select a lead therapeutic mAb and advance into *in vitro* potency testing and *in vivo* assessment of therapeutic efficacy in an *A. baumannii* challenge mouse model.

### **Our MabIgX® and IPEX™ Fully Human Antibody Discovery Platform**

Our proprietary MabIgX and IPEX discovery platforms enable us to rapidly screen, identify and optimize fully human therapeutic mAb product candidates directly from the B-cells of patients. We have developed a method of selecting rare, potent B-cells isolated either from convalescent individuals who have successfully survived an infection with the pathogen or healthy individuals who have been actively immunized with a vaccine against a target pathogen. These B-cells produce antibodies that are highly relevant for the body's defense against a particular pathogen and which we believe will be highly protective mAb therapeutic product candidates. Our mAb product candidates are of completely human origin, which we believe maximizes the antibodies' protection and effector functions and minimizes the risk of adverse reactions.

We believe our MabIgX and IPEX drug discovery platforms, which enable us to rapidly identify and manufacture naturally occurring fully human antibody product candidates, provides us with the following competitive advantages:

- ability to rapidly screen for rare and potent B-cells to produce differentiated mAb product candidates and expeditiously progress product candidates from target identification to clinical development;
- broad applicability to produce immunologically and clinically relevant product candidates across all relevant immunoglobulin isotypes, including IgG, IgA, IgM and IgE antibodies;
- discovery of mAb product candidates with high efficacy due to recognition of epitopes relevant for humans;
- generation of mAb product candidates that are well tolerated and that have the potential for multiple administrations due to low immunogenicity, or nominal ability to provoke an anti-drug immune response; and
- ability to rapidly progress to clinical manufacturing by avoiding the need for time consuming recombinant antibody engineering processes and production cell lines.

Our technology enables us to overcome one of the major challenges in developing human therapeutic mAbs, which is the inability to easily select and culture antigen-induced mAb-producing human B-cells and to use them to construct continuous mAb-producing cell lines. We have defined the properties of circulating antigen-specific human B-cells recruited through the immune response to polysaccharide and protein antigens, and have optimized their enrichment and propagation in culture for the production of fully human mAbs. After isolation, these highly antigen-specific human B-cells are for large scale manufacturing of our fully human mAbs.

Our technology enables us to isolate and select the most relevant and most effective human antibodies for a specific pathogen. Not all pathogens require the same type of immune effector function, and therefore, our immune system has developed a set of different antibody isotypes with very specific characteristics. For example, high-affinity IgG antibodies are more efficient at neutralizing viruses and preventing infections whereas IgM antibodies can more efficiently attack gram-negative bacteria by targeting the bacterial surface polysaccharides and by activating complement, which leads to a "flagging" of the bacteria, known as opsonization, and ultimately the destruction of the bacteria by the immune system. It is important to isolate antibodies of the proper isotype based on the infection targeted and the desired reaction of the human immune system. Our MabIgX technology enables the isolation of the isotype of an antibody that the human immune system utilizes to combat a particular pathogen and isolate all different isotypes.

Our IPEX™ platform technology is also designed to discover new monoclonal antibody products directly from patients but extends beyond MabIgX's utility in its B-cell screening capacity, with its ability to increase mAb productivity from existing mammalian production cell lines, and the involvement of a novel CHO based production cell line technology that differs from MabIgX's usage of hybridoma cell line. APEX allows for the unbiased discovery of new and highly potent antibodies against pathogens and a methodology to maximize the production/yield of selected antibodies on commercial scale. The platform technology is comprised of a silicon wafer-based array of nanoliter sized tissue microculture wells that enable rapid screening of antibody secreting cells, enabling discovery of potent antibodies against targets such as viruses within one day of a pandemic outbreak. It also features CRISPR (Clustered Regularly Interspaced Short Palindromic Repeats) gene editing enabled activation of endogenous genetic control elements that dramatically increase the yield of biotherapeutic drugs from manufacturing production cell lines, and a proprietary production cell line that is designed to rapidly manufacture multiple monoclonal antibody therapeutics at approximately half the manufacturing cycle time than current available manufacturing technologies. We have licensed the CRISPR gene editing technology from the Broad Institute of MIT and Harvard.

IPEX™ is expected to facilitate the rapid discovery and production of critical therapies for companies operating in the biopharmaceutical, biomanufacturing and biosimilar space. A summary of the IPEX technology suite is shown in Figure 10.

**Figure 10**

*IPEX™ Technology Suite Comprises Several Related Technologies that Enable Rapid Discovery of mAb and Scale up Manufacturing*

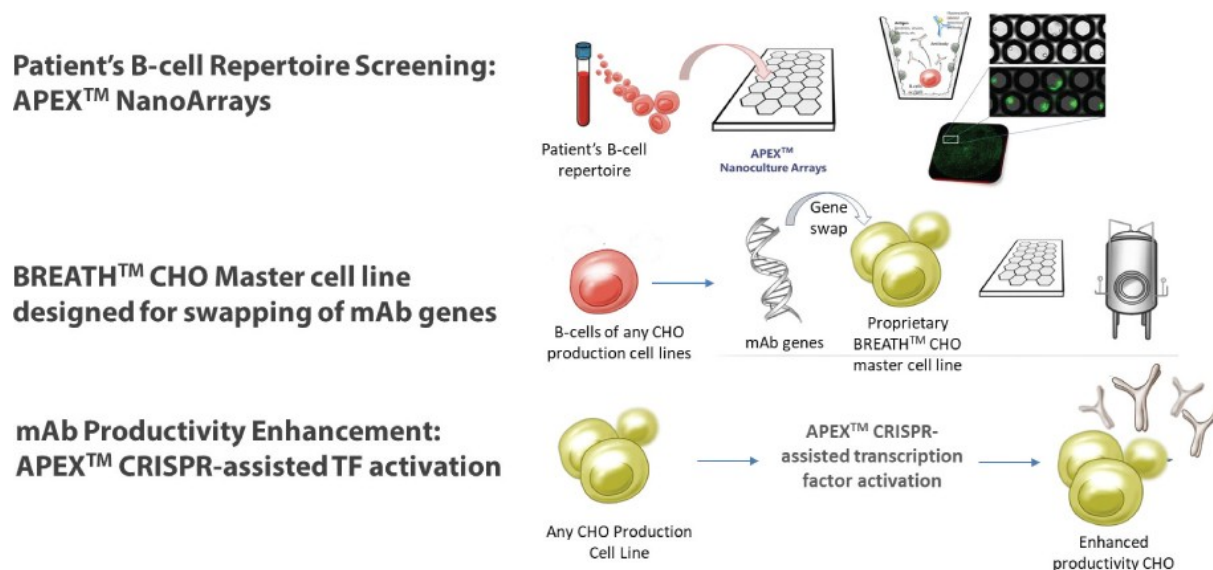

### Intellectual Property

Our success depends, in part, on our ability to obtain, maintain, and enforce patents and other proprietary protections of our commercially important technologies and product candidates, to operate without infringing the proprietary rights of others, and to maintain trade secrets or other proprietary know-how, both in the U.S. and other countries. Our ability to stop third parties from making, using, selling, offering to sell or importing our products will depend on the extent to which we have rights under valid and enforceable patents or trade secrets that protect these activities. We seek to protect proprietary technology, inventions, and improvements that are commercially important to our business by seeking, maintaining, and defending patent rights, whether developed internally or licensed from third parties.

As of December 31, 2021, our patent estate includes approximately 161 issued patents (approximately 32 of which are in the U.S.) and approximately 53 pending patent applications (approximately 8 of which are in the U.S.), which we either own or for which we have an exclusive commercial license (either in its entirety or within our field of use), as is more fully described below.

**AR-301: *Anti-Staphylococcus aureus HLA alphatoxin mAb***

Our AR-301 patent estate includes a patent family that we own related to AR-301 titled “Human Monoclonal Antibody against *S. aureus* derived alphatoxin and its use in treating or preventing abscess formation” which has a priority date of August 10, 2009. Issued claims include: composition of matter claims to a human mAb that binds to *S. aureus* alphatoxin and a cell line producing the antibody. Patents in this family have been issued in Europe, the U.S., China, Israel, India, Japan, Korea and Russia. National patent applications are currently pending in Canada and Brazil. Issued patents are expected to expire in 2030, absent any patent term adjustments or extensions. The portfolio is complemented by a patent family in-licensed from University of Chicago and titled “Methods and Compositions related to Immunizing Against Staphylococcal Lung Diseases and Conditions.” This patent family includes ten patents, which are granted in jurisdictions including Australia, China, Europe, Japan, Korea, and the U.S., and six patent applications that are pending in Brazil, Canada, China, Hong Kong, Japan and the U.S. Patents in this family are expected to expire in 2028, absent any patent term adjustments or extensions.

**AR-501: *Gallium citrate***

Our AR-501 patent estate includes three patent families, two of which we own and one of which is in-licensed from the University of Iowa Research Foundation. These patents are directed to Gallium containing formulations for anti-infective indications and methods of using the same. These patent families include granted patents in Australia, Canada, China, Europe, Hong Kong, Japan, Mexico, New Zealand, South Africa, and the U.S. The in-licensed issued patents are expected to expire in 2024 and the patents that we own are expected to expire in 2030, absent any patent term adjustments or extensions.

**AR-701: *Anti-SAR-CoV-2 mAb***

Our patent estate for AR-701 includes a patent family titled “Human monoclonal antibodies to SARS-CoV2 and use thereof” which has been in-licensed from University of Alabama. The provisional applications were filed in 2020 and 2021.

**AR-401: *Anti-Acinetobacter baumannii mAb***

Our patent estate for AR-401 includes a patent family titled “Novel targets of *Acinetobacter baumannii*” with priority to 2011. This family includes issued patents in Australia, China, Europe and the U.S. Patent applications are pending in Canada, China (divisional), Japan (divisional) and the U.S. (divisional). Claims in these patents and applications include those directed to certain vaccine compositions and to mAb against outer membrane protein targets. Patents in this family are expected to expire in 2032, and any patents that may issue from the pending patent applications are expected to expire in 2032, absent any patent term adjustments or extensions.

**AR-101: *Anti-Pseudomonas aeruginosa LPS serotype O11 mAb***

Our AR-101 patent estate includes a patent family, titled “Human Monoclonal Antibody Specific for LPS of serotype IATS 011 *Pseudomonas aeruginosa*,” with issued patents in seven jurisdictions including Canada, Europe, China, India, Israel, Japan, and the U.S. The issued patents include claims directed to certain antibodies, variants or Fab fragments thereof, hybridomas producing the antibodies, as well as nucleic acids encoding the antibodies. In the U.S. issued claims are directed to antibodies with specific variable region sequences that bind LPS of the *P. aeruginosa* LPS serotype IATS 011, or with variable region sequences having 85% identity thereto. Similar claims were granted in Europe, Canada, China, Israel, India and Japan. Patents in this family are expected to expire in 2026, absent any patent term adjustments or extensions. Additionally, we own a U.S. patent covering the O6 serotype of *P. aeruginosa* LPS titled “Human Monoclonal Antibody Specific for LPS of Serotype IATS O6 *Pseudomonas aeruginosa*”. This issued US patent is expected to expire in 2026, absent any patent term adjustments or extensions.

**AR-201: *Anti-Respiratory Syncytial Virus mAb***

Our patent estate for AR-201 comprises two U.S. patent and pending patent applications in Canada, China, Europe and India titled “Human Monoclonal Antibody Specific for the F Protein of Respiratory Syncytial Virus (RSV).” Claims in the U.S. patents are directed to antibodies with specificity to a region of RSV F protein, methods of producing certain antibodies and methods of treating or preventing RSV infections with such antibodies. The U.S. patents are expected to expire in 2034 and—in case of grant—currently pending patent applications are expected to expire in 2035, absent any patent term adjustments or extensions.

Complementing the product specific patents is a pharmaceutical processing and formulation technology related portfolio comprising five patent families of which one was in-licensed. The patent families consist of nine national patents and patent applications on formulation and delivery technologies. The issued patents have expected expiration ranges between 2022 and 2030, and the pending patent applications are expected to expire between 2022 and 2037, absent any patent term adjustments or extensions. Claims in the patents are directed to formulation, stabilization, and delivery of pharmaceuticals.

We are also actively pursuing additional patent applications in the U.S. and foreign patent jurisdictions for other preclinical product candidates and methods of use, including additional product candidates for infectious disease. In addition, we will pursue patent protection whenever it is deemed sufficiently beneficial for any product or product candidate and related technology we develop and/or acquire in the future.

The patent positions of biotechnology companies like ours are generally uncertain and involve complex legal, scientific and factual questions. In addition, the coverage claimed in a patent application can be significantly reduced before the patent is issued. Consequently, we do not know whether the product candidates we are developing will gain patent protection or, if patents are issued, whether they will provide significant proprietary protection or will be challenged, circumvented, invalidated, or found to be unenforceable. Because patent applications in the U.S. and certain other jurisdictions are maintained in secrecy for 18 months, and since publication of discoveries in the scientific or patent literature often lags behind actual discoveries, we cannot be certain of the priority of inventions or filing dates covered by pending patent applications. Moreover, we may have to participate in post-grant proceedings, interference proceedings, or third-party *ex parte* or *inter partes* reexamination proceedings before the U.S. Patent and Trademark Office, or in opposition proceedings in a foreign patent office, any of which could result in substantial cost to us, even if the eventual outcome is favorable to us. There can be no assurance that the patents, if issued, would be held valid and enforceable by a court of competent jurisdiction. An adverse outcome could subject us to significant liabilities to third parties, require disputed rights to be licensed from third parties or require us to cease using specific compounds or technology. To the extent it is prudent, we intend to bring litigation against third parties that we believe are infringing one or more of our patents or other intellectual property rights.

The term of individual patents depends upon the legal term of the patents in the countries in which they are obtained. In most countries in which we file, the patent term is 20 years from the earliest date of filing a non-provisional patent application. In the U.S., a patent term may be lengthened by patent term adjustment, which compensates a patentee for administrative delays by the U.S. Patent and Trademark Office in granting a patent or may be shortened if a patent is terminally disclaimed over another patent. Some of our patents currently benefit from patent term adjustment and some of our patents that will be issued in the future may benefit from patent term adjustment.

The patent term of a patent that covers an FDA-approved product may also be eligible for patent term extension, which permits patent term restoration as compensation for the patent term lost during the FDA regulatory review process. The Drug Price Competition and Patent Term Restoration Act of 1984, or the Hatch-Waxman Act, permits a patent term extension of up to five years beyond the expiration of the patent. The length of the patent term extension is related to the length of time the product is under regulatory review. Patent term extension cannot extend the remaining term of a patent beyond a total of 14 years from the date of product approval and only one patent applicable to an approved product may be extended. Similar provisions are available in Europe and other non-U.S. jurisdictions to extend the term of a patent that covers an approved product. In the future, if and when our product candidates receive FDA approval, we expect to apply for patent-term extensions on patents covering those products.

To protect our rights to any of our issued patents and proprietary information, we may need to litigate against infringing third parties, or avail ourselves of the courts or participate in hearings to determine the scope and validity of those patents or other proprietary rights. These types of proceedings are often costly and could be very time-consuming to us, and there can be no assurance that the deciding authorities will rule in our favor. An unfavorable decision could allow third-parties to use our technology without being required to pay us licensing fees or may compel us to license needed technologies to avoid infringing third-party patent and proprietary rights. Such a decision could even result in the invalidation or a limitation in the scope of our patents or forfeiture of the rights associated with our patents or pending patent applications.

We also rely on trade secret protection for our confidential and proprietary information. No assurance can be given that others will not independently develop substantially equivalent proprietary information and techniques or otherwise gain access to our trade secrets or disclose such technology, or that we can meaningfully protect our trade secrets. However, we believe that the substantial costs and resources required to develop technological innovations will help us to protect the competitive advantage of our products.

It is our policy to require our employees, consultants, outside scientific collaborators, sponsored researchers and other advisors to execute confidentiality agreements upon the commencement of employment or consulting or collaborative relationships with us. These agreements provide that all confidential information developed or made known to the individual during the course of the individual's relationship with us is to be kept confidential and not disclosed to third parties except in specific circumstances. In the case of employees, the agreements provide that all inventions conceived by the individual shall be and are our exclusive property. There can be no assurance, however, that these agreements will provide meaningful protection or adequate remedies for our trade secrets in the event of unauthorized use or disclosure of such information.

## **Licensing Agreements –**

### ***University Licensing Agreements***

#### *Broad Institute of MIT and Harvard — Non-Exclusive Manufacturing License Agreement*

We entered into a non-exclusive manufacturing licensing agreement with the Broad Institute of MIT and Harvard (the "Broad Institute") in 2021 to make and manufacture CRISPR Modified Cell Lines, CRISPR Modified Animals and CRISPR Modified Plants. These license rights permit the non-exclusive use of the CRISPR Technology for the creation of and improvement of yield from protein and mAb production cell lines, which is one of the core components of the IPEX™ mAb discovery and manufacturing production technology.

Pursuant to this agreement, we are obligated to pay to the Broad Institute an issue fee of \$25,000, an annual license maintenance fee of \$50,000 in 2022, and fees of \$100,000 in 2023 and each year thereafter. Additionally, we are obligated to pay a royalty of a single digit percentage of all service income received from a customer for the manufacture, sale or transfer of CRISPR modified cell line, CRISPR Modified Animals and CRISPR Modified Plants or end products, as well as a small royalty (a fraction of a percent) on end product net sales from use of any commercialized product that contains any small or large molecule made through the use of a CRISPR modified cell line, CRISPR Modified Animals and CRISPR Modified Plants. The term of the license agreement continues until all patents and filed patent applications, included within the licensed Broad Institute patents, have expired or been abandoned.

#### *The University of Alabama at Birmingham Research Foundation — Exclusive Patent License Agreement*

We are party to an exclusive licensing agreement with the University of Alabama at Birmingham Research Foundation (UABRF), a non-profit corporation, for the AR-712 mAb program, which we entered into in 2020. This agreement granted us an exclusive, royalty-bearing license for intellectual property entitled human neutralizing antibodies against SARS-CoV-2/COVID-19. The agreement was amended in 2021 to include the AR-703 mAb program, being UABRF intellectual properties entitled human neutralizing antibodies against SARS-CoV-2 Spike 2 Domain and Uses thereof, and human monoclonal antibodies to SARS-CoV-2 and use thereof. UABRF and Texas Biomedical Research Institute jointly own all rights, title and interest in the intellectual property. The UABRF license agreement also granted us the right to sublicense the technology. UABRF retained the non-transferrable right to use such patent rights for academic and research purposes, and also to certain pre-existing rights of the U.S. government.

The potential development and commercialization milestone payments under the UABRF agreement total up to approximately \$5.5 million. No milestones were met or accrued for as of December 31, 2021. We are also obligated to pay UABRF single digit percentage royalties on net sales from us and our sublicensee's sale of any commercialized licensed product or process, subject to minimum annual amounts starting in 2027. We are obligated to pay UABRF double digit percentage royalties on non-royalty income received during the term of the license agreement, and payments will be reduced by one half for non-royalty income received for a combination product as defined in the agreement. We are responsible for all patent protection expenses.

The term of the license agreement continues until all patents and filed patent applications, included within the licensed UABRF patents, have expired or been abandoned, or until the agreement is earlier terminated. We may terminate the license agreement by giving no less than ninety (90) days prior written notice to UABRF. UABRF has the right to immediately terminate the license agreement upon our uncured material breach of obligations under the agreement.

*The University of Chicago—Exclusive Licensing Agreement*

We are party to an exclusive licensing agreement with The University of Chicago (UChicago) for our AR-301 product candidate, which we entered into in 2018. This exclusive license agreement superseded the co-exclusive license agreement between us and UChicago, which we entered into in 2017. The UChicago agreement granted to us a worldwide exclusive, royalty-bearing license under UChicago’s rights in methods relating to certain licensed patents arising from the disclosure entitled, “Vaccine protection against *Staphylococcus aureus pneumonia*” regarding the work of Professors Juliane Bubeck Wardenburg and Loaf Schneewind. The UChicago agreement also granted to us the right to sublicense. We paid UChicago aggregate exclusivity payments of \$150,000 under the terms of the exclusive license agreement and co-license agreement.

We also are obligated to pay UChicago low single digit percentage royalties on net sales of licensed products, with a minimum royalty required per year once sales begin and ending when the last-to-expire patent covering such product expires, in addition to certain other milestone and other payments. The aggregate milestone payments under the UChicago agreement potentially total up to \$1.6 million.

The agreement provides that we have certain obligations to conduct further research and development and are obligated to utilize reasonable efforts to commercialize the UChicago licensed patent rights as licensed products.

The term of the agreement continues until the expiration of the last to expire patents (which is expected to be in 2031), or until the agreement is earlier terminated. We may terminate the agreement upon 90 days’ prior written notice. Additionally, UChicago will have the right to terminate the agreement upon any of the following events:

- We fail to make a payment within 30 days written notice of default;
- A breach of the agreement occurs that has not been cured in 30 days;
- We become insolvent, make an assignment for the benefit of creditors, or if a petition for bankruptcy is filed;
- We are dissolved or liquidated; and
- We fail to commence specific clinical trials prior to the fifth (5<sup>th</sup>) anniversary of the co-exclusive agreement.

*The Brigham and Women’s Hospital, Inc.—Exclusive Patent License Agreement*

We are party to an exclusive licensing agreement with The Brigham and Women’s Hospital, Inc. (BWH), a non-profit corporation for our AR-105 product candidate, which we entered into in 2010. This agreement granted to us an exclusive, royalty-bearing license under its and Beth Israel Deaconess Medical Center’s, or BIDMC, rights in methods and composition relating to specific binding peptides to *P. aeruginosa* mucoid exopolysaccharide to make, use and sell products and processes for the treatment of pseudomonas infections in humans that are covered by such patent rights worldwide. The BWH Agreement also granted to us the right to sublicense. BWH and BIDMC retained the non-transferrable right to use such patent rights for academic and research purposes, and also to certain pre-existing rights of the U.S. government. We paid BWH \$141,600 within one year of execution of the BWH Agreement.

We are obligated to pay BWH low single digit percentage royalties on net sales from our and our sublicensee’s sale of any commercialized licensed product or process, with a minimum royalty required per year once sales begin, and certain other milestone and other payments. We are responsible for diligently prosecuting and maintaining the licensed patent rights, at our sole cost and expense. The aggregate milestone payments under the BWH Agreement potentially total up to \$860,000.

The agreement provides that we have certain obligations to conduct further research and development, and are obligated to utilize reasonable efforts to commercialize, either directly or through a sublicensee, the licensed BWH patent rights as licensed products or processes.

The term of the agreement continues until all patents and filed patent applications, included within the licensed BWH patents, have expired (which is expected to be in 2025) or been abandoned, or until the agreement is earlier terminated. We may terminate the



agreement on prior written notice to BWH. We have the right to terminate the agreement upon 90 days written notice. Additionally, the BWH Agreement will terminate upon any of the following events:

- We fail to make a payment within 30 days written notice of default;
- We fail to maintain the insurance requirements as defined in the BWH Agreement;
- We become insolvent, make an assignment for the benefit of creditors, or if we file a petition for bankruptcy;
- A breach of the agreement occurs that has not been cured in 60 days; and
- Substantially all of our assets are seized or attached in a final, unappealed or unappealable order in conjunction with any action brought against it by a third-party creditor, such that we are unable to perform our continuing obligations thereunder.

*The University of Iowa Research Foundation—Exclusive Patent License Agreement*

We are party to an exclusive licensing agreement with The University of Iowa Research Foundation (UIRF) relating to our AR-501 product candidate, which we entered into in 2010. The agreement granted to us is an exclusive, royalty-bearing license under its rights in methods relating to gallium containing compounds for the treatment of infections to make, use and sell products that are covered by such patent rights worldwide. The UIRF agreement also granted to us the right to sublicense. UIRF retained the right and ability to grant right to use such patent rights for academic and research purposes, and also to certain pre-existing rights of the U.S. government including the rights of United States Department of Veterans Affairs. We paid \$25,000 to UIRF in connection with entering into the UIRF agreement.

We also are obligated to pay UIRF low single digit percentage royalties on net sales from our and our sublicensee's sale of any commercialized licensed product or process, and certain other milestone and other payments. The aggregate milestone payments under the UIRF agreement potentially total up to \$712,500. We are responsible for diligently prosecuting and maintaining the licensed UIRF patent rights, at our sole cost and expense.

The UIRF agreement provides that we have certain obligations to conduct further research and development, and are obligated to utilize reasonable efforts to commercialize, either directly or through a sublicensee, the licensed UIRF patent rights as licensed products or processes.

The term of the agreement continues until the expiration of the last to expire patents (which is expected to be in 2034), or until the agreement is earlier terminated. We may terminate the agreement on 90 days prior written notice to UIRF. Each party has the right to terminate the agreement for the other party's uncured material breach of obligations under the agreement.

Additionally, the UIRF Agreement will terminate upon any of the following events:

- We fail to make a payment upon 45 days written notice of default; or
- We are involved in liquidation or bankruptcy proceedings unless the remaining party agrees not to terminate.

*Brigham Young University—Exclusive Patent License Agreement*

We are party to an exclusive licensing agreement with Brigham Young University (BYU). This agreement granted to us an exclusive, royalty-bearing license under BYU's rights in stabilization of biological agents methods relating to human vaccines to make, use and sell products that are covered by such patent rights worldwide. The agreement also granted to us the right to sublicense. BYU and the Church of Jesus Christ of Latter-day Saints and the Church Education System retained the right and ability to use such patent rights for academic and ecclesiastical purposes and also to purchase products using such patents rights at a discounted price.

We also are obligated to pay BYU low single digit percentage royalties on the Adjusted Gross Sales as defined in the BYU Agreement, and certain other payments. The aggregate milestone payments under the BYU Agreement potentially total up to \$400,000.

BYU is responsible for diligently prosecuting and maintaining the licensed BYU patent rights and we will reimburse them for one-third of their costs.

The agreement provides that we have certain obligations to conduct further research and development, and are obligated to utilize reasonable efforts to commercialize, either directly or through a sublicensee, the licensed BYU patent rights as licensed products or processes.

The term of the BYU Agreement continues until the expiration of the last to expire patents (which is expected to be in 2022), or until the agreement is earlier terminated. We may terminate the agreement on prior written notice to BYU. Each party has the right to terminate the agreement for the other party's uncured material breach of obligations under the agreement. Additionally, the BYU Agreement will terminate upon any of the following events:

- We are placed in the hands of a receiver or make a general assignment for the benefit of creditors, such that we are unable to perform our obligations under the agreement; or
- Substantially all of our assets or our successor-in interest are seized or attached in a final, unappealed or unappealable order in conjunction with any action brought against us by a third-party creditor, such that we are unable to perform our continuing obligations hereunder.

#### *Cystic Fibrosis Foundation Agreement*

In December 2016, pursuant to a letter agreement between us and the Cystic Fibrosis Foundation, we received an award for up to \$2.9 million from the Cystic Fibrosis Foundation to advance research on potential drugs utilizing inhaled gallium citrate anti infective. On November 26, 2018, pursuant to an amendment to the letter agreement, the Cystic Fibrosis Foundation increased the potential award to up to approximately \$7.5 million. Under the award agreement, the Cystic Fibrosis Foundation will make payments to us as certain milestones are met. The award agreement also contains a provision whereby if we spend less on developing a potential drug utilizing inhaled gallium citrate anti infective than we actually receive under this award agreement, we will be required to return the excess portion of the award to the Cystic Fibrosis Foundation. No liability related to this excess amount was recorded by us as of December 31, 2021 and 2020.

In the event that development efforts are successful and we commercialized a drug from these related development efforts, we may be subject to pay to Cystic Fibrosis Foundation a one-time amount equal to nine times the awarded amount. Such amount shall be paid in not more than five annual installments.

In the event that we license rights to the product in the field to a third-party, sell the product, or consummate a change of control transaction prior to the first commercial sale, we shall pay to the Cystic Fibrosis Foundation an amount equal to fifteen percent (15%) of the amounts received by us and its shareholders in connection with such disposition up to nine times the actual awarded amount received from the Cystic Fibrosis Foundation.

In the event that the development efforts are delayed, which result from events within our control, for more than one hundred eighty (180) consecutive days at any time before we first commercialize the drug from the related development efforts, the Cystic Fibrosis Foundation may provide an interruption notice to us. We then have thirty (30) days to respond to such notice. If we do not respond within thirty (30) days, an interruption license shall be effective. The interruption license to the Cystic Fibrosis Foundation is an exclusive, worldwide license under the development program technology to manufacture, have manufactured, license, use, sell, offer to sell, and support the product in the field and includes financial conditions for both parties.

None of these events have occurred as of December 31, 2021.

#### *Program for Appropriate Technology in Health and PATH Vaccine Solutions*

We granted the Program for Appropriate Technology in Health, or PATH, a global non-profit organization, and the PATH Vaccine Solutions a non-exclusive license, with right to sublicense formulations, for use with the measles, rotavirus, live-attenuated influenza, pneumococcal and enteric vaccines only for sale in developing countries.

We have also agreed to provide rotavirus vaccines to public sector purchasers in developing countries at a preferential price relative to private sector purchasers in developing countries where the rotavirus vaccine utilizing the enabling formulation technology is offered for sale.

### **Corporate Licensing Arrangements**

#### *MedImmune Limited – License Agreement*

In July 2021, the Company executed a license agreement effective July 12, 2021 and entered into an amendment to the license agreement on August 9, 2021 (collectively the “MedImmune License Agreement”) with MedImmune Limited (“MedImmune”), pursuant to which MedImmune granted the Company an exclusive worldwide license for the development and commercialization of suvratomumab, a Phase 3 ready fully human monoclonal antibody targeting the staphylococcus aureus alpha toxin (the “Licensed Product”). As consideration for the MedImmune License Agreement, the Company issued 884,956 shares of its common stock to MedImmune and a \$5.0 million cash payment is due to MedImmune upon the earlier of (i) a registered direct offering in which the Company receives third-party funding or (ii) December 31, 2021. The \$5.0 million liability is unpaid as of December 31, 2021, but is expected to be made in 2022 pending resolution of certain documentary matters. It therefore has been included in accrued liabilities within the Company’s consolidated balance sheet at December 31, 2021, and recorded as research and development expense within its consolidated statement of operations for the year ended December 31, 2021. The fair value of the 884,956 shares of the Company’s common stock issued in connection with the MedImmune License agreement is approximately \$6.5 million (see Note 9) which the Company recognized as research and development expense within its consolidated statement of operations and additional paid-in capital within equity in its consolidated balance sheet during the year ended December 31, 2021.

As additional consideration, the Company will pay MedImmune milestone payments upon the achievement of certain regulatory approvals, for one licensed product, up to a total aggregate amount of \$30.0 million and sales related milestone payments of up to \$85.0 million. There are no development milestone payments. MedImmune is entitled to royalty payments based on aggregate net sales ranging from 12.5% to 15% dependent on net sales volume. Further, until delivery of an interim data readout, or an interim futility analysis, from the first Phase 3 clinical study for any indication, MedImmune has a right of first negotiation regarding any commercial rights that the Company intends to sub-license. The term of the MedImmune License Agreement continues until the expiration of the last royalty term for the last licensed product as defined in the license agreement.

#### *Serum Institute of India (via Serum AMR Products)*

In July 2019, we entered into an Option Agreement for Exclusive Product and Platform Technology License (the Option Agreement) with Serum International BV, a company incorporated in the Netherlands (SIBV). Pursuant to the Option Agreement, SIBV made a fee payment to us in the amount of \$5 million.

In September 2019, we entered into a License, Development and Commercialization Agreement (the License Agreement) with Serum AMR Products, a Netherlands based company (SAMR), which is a wholly owned subsidiary of SIBV, pursuant to the previous Option Agreement, and received an upfront cash payment of \$10 million (in addition to the \$5 million that was initially received upon the parties entering into the Option Agreement).

Pursuant to the License Agreement we granted to SAMR the following:

- a. Limited Territory Intellectual Property (IP) Licenses – exclusive licenses to develop, distribute, market, promote, sell, have sold, offer for sale, import and otherwise commercialize our products related to AR-301, AR-105, and AR-101 (Aridis Products) in (a) the country of India, and (b) all other countries of the world except the USA, Canada, EU Territory, UK, China, Australia, South Korea, Brazil, New Zealand, and Japan (the Limited Territory) for the term of the License Agreement. For our products AR-105 and AR-101, the countries do not exclude South Korea and Brazil. These licenses do not include the right to label, package, manufacture or have manufactured the products; however, we granted to SAMR a separate option for manufacturing rights related to these products, as discussed below.

- b. Worldwide Territory IP License – an exclusive license to develop, manufacture, make, have made, distribute, market, promote, sell, have sold, offer for sale, import and otherwise commercialize the AR-201 product in all countries of the world except China, Hong Kong, Macau and Taiwan (the Worldwide Territory) during the term of the License Agreement.
- c. Research & Development Option – the right for us to provide research services for the identification of up to five (5) candidates for SAMR Products including candidate development and an exclusive license to develop, manufacture, make, have made, distribute, market, promote, sell, have sold, offer for sale, import and otherwise commercialize these development products in the Worldwide Territory, during the term of the License Agreement. The five candidates to be identified and the development plans related to this option were to be agreed upon within 12 months of the License Agreement.
- d. Manufacturing Rights Option – the initial license granted above for the Limited License Products does not allow for manufacturing. This option provides incremental rights related to the Limited License Products beyond what is granted as part of the licensing discussed above—i.e., an exclusive license for use by SAMR to manufacture and supply the Limited License Products for SAMR’s own use (in the Limited Territory) and to manufacture and supply the Products to us or our affiliates (for Aridis’s use outside the Limited Territory) at commercially reasonable rates, and at sufficient capacity as specified in a manufacturing agreement that shall be negotiated and executed in good faith. The term of the manufacturing agreement shall be twenty (20) years. If a third-party sublicensee of Aridis Products wishes to have Aridis Product manufactured by itself for the territory for which it has a license from us, then we shall have the right to buy back the manufacturing rights by paying to SAMR \$5 million.

SAMR agrees to exercise or waive this option by December 31, 2021. However, in order to exercise the option SAMR must first demonstrate, to our reasonable satisfaction, SAMR’s ability for manufacturing consistency of Limited License Products in conformance to all regulatory FDA and EMA requirements. SAMR acknowledges that it must meet expected timelines for the expected approval date for the first Licensed Product and will need to have completed a ready production facility within a specified timeline in order to allow sufficient time for demonstration of capacity and consistency and completion of Quality Agreements. SAMR has not exercised this option as of December 31, 2021.

- e. Development Support Activities – we will share our know-how related to the products in order to assist SAMR in its efforts to develop, receive regulatory approval for, and manufacture and sale the licensed products in SAMR’s authorized territories. This will be performed under the direction of a Joint Steering Committee (JSC) and will follow the development plan approved by the JSC. As part of these activities each party shall share all relevant clinical data and regulatory documentation created by it anywhere in the world.

Additionally, in certain circumstances, SAMR and us will agree to commit to negotiate in good faith to extend the rights granted in the License Agreement to include an exclusive license to make, have made, import, use and have used, and sell and have sold, certain Aridis Products in the European Union during the Term. Such an obligation upon us to negotiate such rights is preconditioned upon the demonstration of certain milestones by SAMR, including its obtaining, under certain funding programs, sufficient financial support to cover all requisite clinical development and manufacturing development costs, under terms which allow distribution of Aridis Products at commercially reasonable prices and without materially hindering distribution of Aridis Products in any other territories.

Pursuant to the License Agreement, SAMR shall make commercially reasonable efforts to obtain all regulatory approvals, to have approved for commercialization and sale, and to commercialize and sell (i) Aridis Products in the Limited Territory, and (ii) SAMR Products and the AR-201 product in the Worldwide Territory.

In addition to the upfront payments noted above, upon the achievement of certain milestones, SAMR shall pay us up to \$42.5 million in milestone fees related to the products covered in the License Agreement. SAMR shall also be obligated to pay us royalties ranging from 4% to 6% on net sales of all licensed products, except for Aridis Products in the European Union, should such be authorized at a later date, which require payment of 20% royalties on the net sales of those products.

*Kenta Biotech Ltd.*

We are a party to an asset purchase agreement with Kenta Biotech Ltd., (Kenta), a for profit corporation incorporated in Schlieren (Canton of Zurich, Switzerland). The asset purchase agreement contains a licensing arrangement based upon the worldwide out-licensing or net sales of certain of Kenta's physical assets, contracts and technology. Pursuant to such agreement, we were obligated to pay Kenta a fixed purchase price, which was fully paid during 2013 and 2014, and are obligated to pay a declining scale of royalties on gross licensing revenues from either out-licensing of the assets or net sales revenues actually received by us up to a maximum of \$50 million.

The agreement also assigned and transferred certain of Kenta's physical assets, contracts and technology to us. The physical assets included all physical assets owned or controlled by Kenta, including but not limited to cell lines, genes, antibodies, diagnostic assays and related documentation, which were related to Kenta's MabIgX technology platform for hybridoma generation and its mAb targeting *S. aureus*, *P. aeruginosa*, *A. baumannii* and RSV. The technology included all intellectual property, including but not limited to patents, patent applications, trademarks, knowhow, trade secrets, regulatory filings, clinical trials, clinical trial information, all supporting documentation and all other related intellectual property which are related to Kenta's MabIgX technology platform for hybridoma generation and its mAb targeting *S. aureus*, *P. aeruginosa*, *A. baumannii* and RSV. The contracts included the contracts and agreements (including all rights and obligations thereunder), whether oral or written, which Kenta has concluded and which pertain to the assets. The contracts were primarily related to the ongoing clinical trial of AR-301.

*Emergent Product Development Gaithersburg Inc.*

We are party to a license agreement with Emergent Product Development Gaithersburg Inc. (Emergent), which we entered into in 2010. We granted Emergent an exclusive, perpetual, royalty-bearing license to use certain of our patents and related know how for the prevention or treatment of infection or illness caused by biodefense pathogens. We also granted a non-exclusive, royalty-bearing license to use certain of our patents and related know how for the prevention or treatment of tularemia and viral hemorrhagic fever indications. Both exclusive and non-exclusive licenses grants Emergent the opportunity to Exploit Licensed Products as defined in the Emergent Agreement in all of the countries of the world. There are currently no commercialized Exploit Licensed Products using this technology.

Emergent is obligated to pay us low single digit percentage royalties on net sales from their and their sublicensee's sale of any commercialized licensed product, and certain other payments. The aggregate milestone payments that we are entitled to pursuant to the Emergent Agreement potentially total up to \$2.8 million.

The term of the Emergent Agreement continues until expiration of all royalty obligations or until the agreement is earlier terminated. Emergent may terminate the agreement upon 60 days prior written notice. In addition, the Emergent Agreement terminates in the event the parties mutually agree to terminate the agreement.

**Joint Venture**

*Joint Venture with Shenzhen Hepalink Pharmaceutical Group Co., Ltd.*

We entered into a Joint Venture Contract, as amended, effective August 6, 2018, (JV Agreement) with Shenzhen Hepalink Pharmaceutical Group Co., Ltd., a People's Republic of China company (Hepalink), a related party and significant shareholder in the Company, pursuant to which we formed a Joint Venture company named Shenzhen Arimab BioPharmaceuticals Co., Ltd. (SABC), a People's Republic of China Company, to develop, manufacture, import and distribute AR-101, AR-301 and AR-105 in China, Hong Kong, Macau and Taiwan, collectively, referred to as the Territory. The Joint Venture received regulatory approval in China and SABC was formed on July 2, 2018.

Hepalink contributed the equivalent of \$7.2 million in renminbi, the official currency of the People's Republic of China, and owns 51% of the capital of SABC and we contributed (i) \$1.0 million in cash and (ii) a license to AR-101, AR-301 and AR-105 pursuant to an Amended and Restated Technology License and Collaboration Agreement between us and SABC and we own 49% of the capital of SABC. In addition, Hepalink will provide SABC with clinical and regulatory personnel services for clinical and regulatory review, application and filing procedures in the Territory and we will provide clinical and regulatory personnel services to assist in coordination of the execution of the clinical study in China and also with CMC personnel services for drug supply and manufacturing planning.

## [Table of Contents](#)

Hepalink is obligated to make an additional equity investment of \$10.8 million into SABC in connection with a future financing of SABC provided that (i) such financing does not occur earlier than January 1, 2019, (ii) top-line clinical results of the first global AR-301 Phase 3 study are available, (iii) CFDA approval for a Phase 3 clinical trial in China is granted, (iv) we have not breached the Amended and Restated Technology License and Collaboration Agreement and (v) the SABC Board has approved such financing. If and to the extent these milestone events occur and Hepalink contributes additional capital to SABC, our 49% ownership stake in SABC will be diminished in proportion to such investment. It was agreed by the parties that we shall be reimbursed for certain legal and contract manufacturing expenses related to the clinical drug supply for a Phase 3 clinical study of AR-301 and the clinical drug supply for a clinical study of AR-105.

The Board of Directors of SABC consists of five directors, of which Hepalink appoints three members and we appoint two members. The term of office for each director is for four years. The Chief Executive Officer and Chief Financial Officer of SABC were approved by unanimous consent of the Board of Directors of SABC. The term of SABC is 20 years from the date of formation.

The JV Agreement will terminate and SABC will be dissolved in the event that:

- The term expires and is not extended;
- The parties decide to terminate the JV Agreement;
- A party fails to contribute funds for the capital it subscribed for and such failure exceeds six months;
- A party is involved in liquidation or bankruptcy proceedings unless the remaining party agrees not to terminate;
- A party fails to obtain approval of a resolution requiring the unanimous vote of the Board and such party notifies the other party that such failure will materially adversely affect SABC and cannot be resolved;
- A force majeure event prevails for a period in excess of six months;
- A breach of the agreement occurs and has not been cured in 60 days; or
- Either we or SABC terminates the Technology License and Collaboration Agreement in accordance with its terms.

### **Government Regulation**

We operate in a highly regulated industry that is subject to significant federal, state, local and foreign regulation. Our present and future business has been, and will continue to be, subject to a variety of laws including, the Federal Food, Drug, and Cosmetic Act, or FDC Act, and the Public Health Service Act, among others.

The FDC Act and other federal and state statutes and regulations govern the testing, manufacture, safety, effectiveness, labeling, storage, record keeping, approval, advertising and promotion of our products. As a result of these laws and regulations, product development and product approval processes are very expensive and time-consuming.

#### *FDA Approval Process*

In the United States, pharmaceutical products, including biologics, are subject to extensive regulation by the FDA. The FDC Act and other federal and state statutes and regulations, govern, among other things, the research, development, testing, manufacture, storage, recordkeeping, approval, labeling, promotion and marketing, distribution, post-approval monitoring and reporting, sampling, and import and export of pharmaceutical products. Failure to comply with applicable U.S. requirements may subject a company to a variety of administrative or judicial sanctions, such as FDA refusal to approve pending new drug applications, or NDAs, or biologic license applications, or BLAs, warning letters, product recalls, product seizures, total or partial suspension of production or distribution, injunctions, fines, civil penalties, and criminal prosecution.

Pharmaceutical product development in the United States typically involves preclinical laboratory and animal tests, the submission to the FDA of an IND, which must become effective before clinical testing may commence, and adequate and well-controlled clinical trials to establish the safety and effectiveness of the drug or biologic for each indication for which FDA approval is sought. Satisfaction of FDA pre-market approval requirements typically takes many years and the actual time required may vary substantially based upon the type, complexity and novelty of the product or disease.

Preclinical tests include laboratory evaluation as well as animal trials to assess the characteristics and potential pharmacology and toxicity of the product. The conduct of the preclinical tests must comply with federal regulations and requirements including good laboratory practices. The results of preclinical testing are submitted to the FDA as part of an IND along with other information, including information about product chemistry, manufacturing and controls, and a proposed clinical trial protocol. Long term preclinical tests, such as animal tests of reproductive toxicity and carcinogenicity, may continue after the IND is submitted.

A 30-day waiting period after the submission of each IND is required prior to the commencement of clinical testing in humans. If the FDA has not objected to the IND within this 30-day period, the clinical trial proposed in the IND may begin.

Clinical trials involve the administration of the investigational drug to healthy volunteers or patients under the supervision of a qualified investigator. Clinical trials must be conducted in compliance with federal regulations and good clinical practices, or GCP, as well as under protocols detailing the objectives of the trial, the parameters to be used in monitoring safety and the effectiveness criteria to be evaluated. Each protocol involving testing on U.S. patients and subsequent protocol amendments must be submitted to the FDA as part of the IND.

The FDA may order the temporary or permanent discontinuation of a clinical trial at any time or impose other sanctions if it believes that the clinical trial is not being conducted in accordance with FDA requirements or presents an unacceptable risk to the clinical trial patients. The clinical trial protocol and informed consent information for patients in clinical trials must also be submitted to an institutional review board, or IRB, for approval. An IRB may also require the clinical trial at the site to be halted, either temporarily or permanently, for failure to comply with the IRB's requirements, or may impose other conditions.

Clinical trials to support NDAs or BLAs, which are applications for marketing approval, are typically conducted in three sequential Phases, but the Phases may overlap. In Phase 1, the initial introduction of the investigational drug candidate into healthy human subjects or patients, the investigational drug is tested to assess metabolism, pharmacokinetics, pharmacological actions, side effects associated with increasing doses and, if possible, early evidence on effectiveness. Phase 2 usually involves trials in a limited patient population, to determine the effectiveness of the investigational drug for a particular indication or indications, dosage tolerance and optimum dosage, and identify common adverse effects and safety risks. In the case of product candidates for severe or life-threatening diseases such as pneumonia, the initial human testing is often conducted in patients rather than in healthy volunteers.

If an investigational drug demonstrates evidence of effectiveness and an acceptable safety profile in Phase 2 evaluations, Phase 3 clinical trials are undertaken to obtain additional information about clinical efficacy and safety in a larger number of patients, typically at geographically dispersed clinical trial sites, to permit the FDA to evaluate the overall benefit-risk relationship of the investigational drug and to provide adequate information for its labeling.

After completion of the required clinical testing, an NDA or, in the case of a biologic, a BLA, is prepared and submitted to the FDA. FDA approval of the marketing application is required before marketing of the product may begin in the United States. The marketing application must include the results of all preclinical, clinical and other testing and a compilation of data relating to the product's pharmacology, chemistry, manufacture, and controls.

The FDA has 60 days from its receipt of an NDA or BLA to determine whether the application will be accepted for filing based on the agency's threshold determination that it is sufficiently complete to permit substantive review. Once the submission is accepted for filing, the FDA begins an in-depth review. The FDA has agreed to certain performance goals in the review of marketing applications. Most such applications for non-priority drug products are reviewed within ten months. The review process may be extended by the FDA for three additional months to consider new information submitted during the review or clarification regarding information already provided in the submission. The FDA may also refer applications for novel drug products or drug products that present difficult questions of safety or efficacy to an advisory committee, typically a panel that includes clinicians and other experts, for review, evaluation and a recommendation as to whether the application should be approved. The FDA is not bound by the recommendation of an advisory

committee, but it generally follows such recommendations. Before approving a marketing application, the FDA will typically inspect one or more clinical sites to assure compliance with GCP.

Additionally, the FDA will inspect the facility or the facilities at which the drug product is manufactured. The FDA will not approve the NDA or, in the case of a biologic, the BLA unless compliance with cGMPs is satisfactory and the marketing application contains data that provide substantial evidence that the product is safe and effective in the indication studied. Manufacturers of biologics also must comply with FDA's general biological product standards.

After the FDA evaluates the NDA or BLA and the manufacturing facilities, it issues an approval letter or a complete response letter. A complete response letter outlines the deficiencies in the submission and may require substantial additional testing or information in order for the FDA to reconsider the application. If and when those deficiencies have been addressed in a resubmission of the marketing application, the FDA will re-initiate review. If the FDA is satisfied that the deficiencies have been addressed, the agency will issue an approval letter. The FDA has committed to reviewing such resubmissions in two or six months depending on the type of information included. It is not unusual for the FDA to issue a complete response letter because it believes that the drug product is not safe enough or effective enough or because it does not believe that the data submitted are reliable or conclusive.

An approval letter authorizes commercial marketing of the drug product with specific prescribing information for specific indications. As a condition of approval of the marketing application, the FDA may require substantial post-approval testing and surveillance to monitor the drug product's safety or efficacy and may impose other conditions, including labeling restrictions, which can materially affect the product's potential market and profitability. Once granted, product approvals may be withdrawn if compliance with regulatory standards is not maintained or problems are identified following initial marketing.

#### *Orphan Drug Act in the United States*

The Orphan Drug Act provides incentives to manufacturers to develop and market drugs for rare diseases and conditions affecting fewer than 200,000 persons in the U.S. at the time of application for orphan drug designation. Orphan drug designation must be requested before submitting a BLA. Orphan drug designation does not convey any advantage in, or shorten the duration of, the regulatory review and approval process. If a product that has orphan drug designation subsequently receives the first FDA approval for the disease for which it has such designation, the holder of the approval is entitled to a seven-year exclusive marketing period in the U.S. for that product except in very limited circumstances. For example, a drug that the FDA considers to be clinically superior to, or different from, another approved orphan drug, even though for the same indication, may also obtain approval in the U.S. during the seven-year exclusive marketing period. In addition, holders of exclusivity for orphan drugs are expected to assure the availability of sufficient quantities of their orphan drugs to meet the needs of patients. Failure to do so could result in the withdrawal of marketing exclusivity for the drug.

QIDP Designation is awarded to antibacterial or antifungal product candidates for human use that are intended to treat serious or life-threatening infections caused by certain bacterial or fungal pathogens that are deemed to be a particular threat to public health. QIDP designated products have a five-year market exclusivity extension and receive priority review for the first application submitted for product approval.

#### *Orphan Designation and Exclusivity in the European Union*

Products authorized as "orphan medicinal products" in the EU are entitled to certain exclusivity benefits. In accordance with Article 3 of Regulation (EC) No. 141/2000 of the European Parliament and of the Council of 16 December 1999 on orphan medicinal products, a medicinal product may be designated as an orphan medicinal product if: (1) it is intended for the diagnosis, prevention or treatment of a life-threatening or chronically debilitating condition; (2) either (a) such condition affects no more than five in 10,000 persons in the European Union when the application is made, or (b) the product, without the incentives derived from orphan medicinal product status, would not generate sufficient return in the European Union to justify investment; and (3) there exists no satisfactory method of diagnosis, prevention or treatment of such condition authorized for marketing in the EU, or if such a method exists, the product will be of significant benefit to those affected by the condition.

An application for orphan drug designation must be submitted before the application for marketing authorization. Orphan drug designation does not convey any advantage in, or shorten the duration of, the regulatory review and approval process.



Products authorized in the EU as orphan medicinal products are entitled to 10 years of market exclusivity. The 10-year market exclusivity may be reduced to six years if, at the end of the fifth year, it is established that the product no longer meets the criteria for orphan designation, for example, if the product is sufficiently profitable not to justify maintenance of market exclusivity. Additionally, marketing authorization may be granted to a similar product during the 10-year period of market exclusivity for the same therapeutic indication at any time if:

- The second applicant can establish in its application that its product, although similar to the orphan medicinal product already authorized, is safer, more effective or otherwise clinically superior;
- The holder of the marketing authorization for the original orphan medicinal product consents to a second orphan medicinal product application; or
- The holder of the marketing authorization for the original orphan medicinal product cannot supply enough orphan medicinal product.

#### *Other Regulatory Requirements*

Once a NDA or BLA is approved, a product will be subject to certain post-approval requirements. For instance, the FDA closely regulates the post-approval marketing and promotion of therapeutic products, including standards and regulations for direct-to-consumer advertising, off-label promotion, industry-sponsored scientific and educational activities and promotional activities involving the internet.

Biologics may be marketed only for the approved indications and in accordance with the provisions of the approved labeling. Changes to some of the conditions established in an approved application, including changes in indications, labeling, or manufacturing processes or facilities, require submission and FDA approval of a new BLA or BLA supplement, before the change can be implemented. A BLA supplement for a new indication typically requires clinical data similar to that in the original application, and the FDA uses the same procedures and actions in reviewing BLA supplements as it does in reviewing BLAs. We cannot be certain that the FDA or any other regulatory agency will grant approval for our product candidates for any other indications or any other product candidate for any indication on a timely basis, if at all.

Adverse event reporting and submission of periodic reports is required following FDA approval of a BLA. The FDA also may require post-marketing testing, known as Phase 4 testing, risk evaluation and mitigation strategies, and surveillance to monitor the effects of an approved product or place conditions on an approval that could restrict the distribution or use of the product. In addition, quality control as well as product manufacturing, packaging, and labeling procedures must continue to conform to cGMPs after approval. Manufacturers and certain of their subcontractors are required to register their establishments with the FDA and certain state agencies and are subject to periodic unannounced inspections by the FDA during which the agency inspects manufacturing facilities to assess compliance with cGMPs. Accordingly, manufacturers must continue to expend time, money and effort in the areas of production and quality control to maintain compliance with cGMPs. Regulatory authorities may withdraw product approvals or request product recalls if a company fails to comply with regulatory standards, if it encounters problems following initial marketing, or if previously unrecognized problems are subsequently discovered.

#### *Companion Diagnostic Review and Approval*

Some of our product candidates currently may rely upon the use of a companion microbial diagnostic test to select patients who are infected with either *S. aureus*, *P. aeruginosa*, or *A. baumannii* bacteria and in the future, we may utilize other biomarkers as companion diagnostic tests for our other product candidates. Approval of our product candidates may require FDA approval of a Premarket Approval Application, or PMA, for a reproducible, validated diagnostic test to be used with our mAb product candidates.

The PMA process is costly, lengthy, and uncertain, although the PMA review for the microbial tests is not currently planned to occur concurrently with the development and review of a BLA for our product candidates. The receipt and timing of PMA approval may have a significant effect on the receipt and timing of commercial approval for our product candidates. Human diagnostic products are subject to pervasive and ongoing regulatory obligations, including the submission of medical device reports, adherence to the Quality Systems Regulation, recordkeeping and product labeling, as enforced by the FDA and comparable state authorities.

*U.S. Foreign Corrupt Practices Act*

The U.S. Foreign Corrupt Practices Act, to which we are subject, prohibits corporations and individuals from engaging in certain activities to obtain or retain business or to influence a person working in an official capacity. It is illegal to pay, offer to pay or authorize the payment of anything of value to any foreign government official, government staff member, political party or political candidate in an attempt to obtain or retain business or to otherwise influence a person working in an official capacity.

*Federal and State Fraud and Abuse Laws*

Healthcare providers, physicians and third-party payors play a primary role in the recommendation and prescription of drug and biologic product candidates which obtain marketing approval. In addition to FDA restrictions on marketing of pharmaceutical products, pharmaceutical manufacturers are exposed, directly, or indirectly, through customers, to broadly applicable fraud and abuse and other healthcare laws and regulations that may affect the business or financial arrangements and relationships through which a pharmaceutical manufacturer can market, sell and distribute drug and biologic products. These laws include, but are not limited to:

The federal Anti-Kickback Statute which prohibits, any person or entity from, among other things, knowingly and willfully offering, paying, soliciting, or receiving any remuneration, directly or indirectly, overtly or covertly, in cash or in-kind, to induce or reward either the referring of an individual for, or the purchasing, leasing, ordering, or arranging for the purchase, lease, or order of any healthcare item or service reimbursable, in whole or in part, under Medicare, Medicaid, or any other federally financed healthcare program. The term “remuneration” has been broadly interpreted to include anything of value. This statute has been interpreted to apply to arrangements between pharmaceutical manufacturers on one hand and prescribers, purchasers, and formulary managers on the other hand. Although there are a number of statutory exceptions and regulatory safe harbors protecting certain common activities from prosecution, the exceptions and safe harbors are drawn narrowly, and practices that involve remuneration intended to induce prescribing, purchases, or recommendations may be subject to scrutiny if they do not qualify for an exception or safe harbor.

The federal false claims and civil monetary penalty laws, including the Federal False Claims Act, which imposes significant penalties and can be enforced by private citizens through civil qui tam actions, prohibits any person or entity from, among other things, knowingly presenting, or causing to be presented, a false, fictitious or fraudulent claim for payment to the federal government, or knowingly making, using or causing to be made, a false statement or record material to a false or fraudulent claim to avoid, decrease or conceal an obligation to pay money to the federal government. In addition, a claim including items or services resulting from a violation of the federal Anti-Kickback Statute constitutes a false or fraudulent claim for purposes of the Federal False Claims Act. As a result of a modification made by the Federal Fraud Enforcement and Recovery Act of 2009, a claim includes “any request or demand” for money or property presented to the U.S. government. In addition, manufacturers can be held liable under the False Claims Act even when they do not submit claims directly to government payors if they are deemed to “cause” the submission of false or fraudulent claims. Criminal prosecution is also possible for making or presenting a false, fictitious or fraudulent claim to the federal government. Recently, several pharmaceutical and other healthcare companies have been prosecuted under these laws for allegedly providing free product to customers with certain expectation that the customers would bill federal programs for the product. Other companies have been prosecuted for causing false claims to be submitted because of the company’s marketing of the product for unapproved, and thus non-reimbursable, uses.

The federal Health Insurance Portability and Accountability Act of 1996, or HIPAA, which, among other things, imposes criminal liability for executing or attempting to execute a scheme to defraud any healthcare benefit program, including private third-party payors, knowingly and willfully embezzling or stealing from a healthcare benefit program, willfully obstructing a criminal investigation of a healthcare offense, and creates federal criminal laws that prohibit knowingly and willfully falsifying, concealing or covering up a material fact or making any materially false, fictitious or fraudulent statements or representations, or making or using any false writing or document knowing the same to contain any materially false, fictitious or fraudulent statement or entry in connection with the delivery of, or payment for, benefits, items or services.

HIPAA, as amended by the Health Information Technology for Economic and Clinical Health Act of 2009, or HITECH, and its implementing regulations, which impose certain requirements relating to the privacy, security, transmission and breach reporting of individually identifiable health information upon entities subject to the law, such as health plans, healthcare clearinghouses and certain healthcare providers and their respective business associates that perform services for them that involve individually identifiable health information. HITECH also created new tiers of civil monetary penalties, amended HIPAA to make civil and criminal penalties directly

applicable to business associates, and gave state attorneys general new authority to file civil actions for damages or injunctions in U.S. federal courts to enforce the federal HIPAA laws and seek attorneys' fees and costs associated with pursuing federal civil actions.

The federal physician payment transparency requirements, sometimes referred to as the "Physician Payments Sunshine Act," and its implementing regulations, which require certain manufacturers of drugs, devices, biologics and medical supplies for which payment is available under Medicare, Medicaid or the Children's Health Insurance Program (with certain exceptions) to report annually to the United States Department of Health and Human Services, or HHS, information related to payments or other transfers of value made to physicians (defined to include doctors, dentists, optometrists, podiatrists and chiropractors) and teaching hospitals, as well as ownership and investment interests held by physicians and their immediate family members.

State and foreign law equivalents of each of the above federal laws, such as anti-kickback and false claims laws, that may impose similar or more prohibitive restrictions, and may apply to items or services reimbursed by non-governmental third-party payors, including private insurers.

State laws that require pharmaceutical companies to implement compliance programs, comply with the pharmaceutical industry's voluntary compliance guidelines and the relevant compliance guidance promulgated by the federal government, or to track and report gifts, compensation and other remuneration provided to physicians and other healthcare providers, state and local laws that require the registration of pharmaceutical sales representatives, and other federal, state and foreign laws that govern the privacy and security of health information or personally identifiable information in certain circumstances, including state health information privacy and data breach notification laws which govern the collection, use, disclosure, and protection of health-related and other personal information, many of which differ from each other in significant ways and often are not pre-empted by HIPAA, thus requiring additional compliance efforts.

Because of the breadth of these laws and the narrowness of the safe harbors, it is possible that some business activities can be subject to challenge under one or more of such laws. The scope and enforcement of each of these laws is uncertain and subject to rapid change in the current environment of healthcare reform, especially in light of the lack of applicable precedent and regulations. Federal and state enforcement bodies have recently increased their scrutiny of interactions between healthcare companies and healthcare providers, which has led to a number of investigations, prosecutions, convictions and settlements in the healthcare industry.

Ensuring that business arrangements with third parties comply with applicable healthcare laws and regulations is costly and time consuming. If business operations are found to be in violation of any of the laws described above or any other applicable governmental regulations a pharmaceutical manufacturer may be subject to penalties, including civil, criminal and administrative penalties, damages, fines, disgorgement, individual imprisonment, exclusion from governmental funded healthcare programs, such as Medicare and Medicaid, contractual damages, reputational harm, diminished profits and future earnings, additional reporting obligations and oversight if subject to a corporate integrity agreement or other agreement to resolve allegations of non-compliance with these laws, and curtailment or restructuring of operations, any of which could adversely affect a pharmaceutical manufacturer's ability to operate its business and the results of its operations.

#### *Health care reform measures could adversely affect our business*

In the United States and foreign jurisdictions, there have been, and continue to be, a number of legislative and regulatory changes and proposed changes to the healthcare system that could affect our future results of operations. In particular, there have been and continue to be a number of initiatives at the U.S. federal and state levels that seek to reduce healthcare costs. In 2010, the PPACA was enacted, which includes measures to significantly change the way health care is financed by both governmental and private insurers. Among the provisions of the Patient Protection and Affordable Care Act (PPACA) of greatest importance to the pharmaceutical and biotechnology industry are the following:

- an annual, nondeductible fee on any entity that manufactures or imports certain branded prescription drugs and biologic agents, apportioned among these entities according to their market share in certain government healthcare programs;
- implementation of the federal physician payment transparency requirements, sometimes referred to as the "Physician Payments Sunshine Act";

- a licensure framework for follow-on biologic products;
- a new Patient-Centered Outcomes Research Institute to oversee, identify priorities in, and conduct comparative clinical effectiveness research, along with funding for such research;
- establishment of a Center for Medicare Innovation at the Centers for Medicare & Medicaid Services, or CMS, to test innovative payment and service delivery models to lower Medicare and Medicaid spending, potentially including prescription drug spending;
- an increase in the statutory minimum rebates a manufacturer must pay under the Medicaid Drug Rebate Program, to 23.1% and 13% of the average manufacturer price for most branded and generic drugs, respectively and capped the total rebate amount for innovator drugs at 100% of the Average Manufacturer Price, or AMP;
- a new methodology by which rebates owed by manufacturers under the Medicaid Drug Rebate Program are calculated for certain drugs and biologics, including our product candidates, that are inhaled, infused, instilled, implanted or injected;
- extension of manufacturers' Medicaid rebate liability to covered drugs dispensed to individuals who are enrolled in Medicaid managed care organizations;
- expansion of eligibility criteria for Medicaid programs by, among other things, allowing states to offer Medicaid coverage to additional individuals and by adding new mandatory eligibility categories for individuals with income at or below 133% of the federal poverty level, thereby potentially increasing manufacturers' Medicaid rebate liability;
- a new Medicare Part D coverage gap discount program, in which manufacturers must agree to offer 70% point-of-sale discounts off negotiated prices of applicable brand drugs to eligible beneficiaries during their coverage gap period, as a condition for the manufacturers' outpatient drugs to be covered under Medicare Part D; and
- expansion of the entities eligible for discounts under the Public Health program.

Some of the provisions of the PPACA have yet to be implemented, and there have been legal and political challenges to certain aspects of the PPACA. During President Trump's administration, he signed two executive orders and other directives designed to delay, circumvent, or loosen certain requirements mandated by the PPACA. Concurrently, Congress has considered legislation that would repeal or repeal and replace all or part of the PPACA. While Congress has not passed repeal legislation, the Tax Cuts and Jobs Act of 2017 ("TCJA") includes a provision repealing, effective January 1, 2019, the tax-based shared responsibility payment imposed by the PPACA on certain individuals who fail to maintain qualifying health coverage for all or part of a year that is commonly referred to as the "individual mandate". Congress may consider other legislation to repeal or replace elements of the PPACA.

Many of the details regarding the implementation of the PPACA are yet to be determined, and at this time, the full effect that the PPACA would have on our business remains unclear. In particular, there is uncertainty surrounding the applicability of the biosimilars provisions under the PPACA to our product candidates. The FDA has issued several guidance documents, and withdrawn others, but no implementing regulations on biosimilars have been adopted. A number of biosimilar applications have been approved over the past few years. It is not certain that we will receive 12 years of biologics marketing exclusivity for any of our products. The regulations that are ultimately promulgated and their implementation are likely to have considerable impact on the way we conduct our business and may require us to change current strategies. A biosimilar is a biological product that is highly similar to an approved drug notwithstanding minor differences in clinically inactive components, and for which there are no clinically meaningful differences between the biological product and the approved drug in terms of the safety, purity, and potency of the product.

Individual states have become increasingly aggressive in passing legislation and implementing regulations designed to control pharmaceutical and biological product pricing, including price or patient reimbursement constraints, discounts, restrictions on certain product access, and marketing cost disclosure and transparency measures, and to encourage importation from other countries and bulk purchasing. Legally mandated price controls on payment amounts by third-party payors or other restrictions could harm a pharmaceutical manufacturer's business, results of operations, financial condition and prospects. In addition, regional healthcare authorities and

individual hospitals are increasingly using bidding procedures to determine what pharmaceutical products and which suppliers will be included in their prescription drug and other healthcare programs. This could reduce ultimate demand for certain products or put pressure on product pricing, which could negatively affect a pharmaceutical manufacturer's business, results of operations, financial condition and prospects.

In addition, given recent federal and state government initiatives directed at lowering the total cost of healthcare, Congress and state legislatures will likely continue to focus on healthcare reform, the cost of prescription drugs and biologics and the reform of the Medicare and Medicaid programs. While we cannot predict the full outcome of any such legislation, it may result in decreased reimbursement for drugs and biologics, which may further exacerbate industry-wide pressure to reduce prescription drug prices. This could harm our ability to generate revenues. Increases in importation or re-importation of pharmaceutical products from foreign countries into the United States could put competitive pressure on our ability to profitably price our products, which, in turn, could adversely affect our business, results of operations, financial condition and prospects. We might elect not to seek approval for or market our products in foreign jurisdictions in order to minimize the risk of re-importation, which could also reduce the revenue we generate from our product sales. It is also possible that other legislative proposals having similar effects will be adopted.

Furthermore, regulatory authorities' assessment of the data and results required to demonstrate safety and efficacy can change over time and can be affected by many factors, such as the emergence of new information, including on other products, changing policies and agency funding, staffing and leadership. We cannot be sure whether future changes to the regulatory environment will be favorable or unfavorable to our business prospects. For example, average review times at the FDA for marketing approval applications can be affected by a variety of factors, including budget and funding levels and statutory, regulatory and policy changes.

#### *Regulation in the European Union*

Biologics are also subject to extensive regulation outside of the U.S. In the EU, for example, there is a centralized approval procedure that authorizes marketing of a product in all countries of the EU, which includes most major countries in Europe. If this procedure is not used, approval in one country of the European Union can be used to obtain approval in another country of the EU under two simplified application processes, the mutual recognition procedure or the decentralized procedure, both of which rely on the principle of mutual recognition. After receiving regulatory approval through any of the European registration procedures, pricing and reimbursement approvals are also required in most countries.

#### *Other Regulations*

We are also subject to numerous federal, state and local laws relating to such matters as safe working conditions, manufacturing practices, environmental protection, fire hazard control, and disposal of hazardous or potentially hazardous substances and biological materials. We may incur significant costs to comply with such laws and regulations now or in the future.

#### **Reimbursement**

Obtaining coverage and reimbursement approval for a product from a government or other third-party payor is a time-consuming and costly process that can require the provision of supporting scientific, clinical and cost effectiveness data for the use of drug or biologic products to the payor. There may be significant delays in obtaining such coverage and reimbursement for newly approved products, and coverage may be more limited than the purposes for which the product is approved by the FDA or similar regulatory authorities outside of the United States. Moreover, eligibility for coverage and reimbursement does not imply that a product will be paid for in all cases or at a rate that covers operating costs, including research, development, intellectual property, manufacture, sale and distribution expenses. Reimbursement rates may vary according to the use of the product and the clinical setting in which it is used, may be based on reimbursement levels already set for lower cost products and may be incorporated into existing payments for other services. Net prices for products may be reduced by mandatory discounts or rebates required by government healthcare programs or private payors and by any future relaxation of laws that presently restrict imports of product from countries where they may be sold at lower prices than in the U.S.

There is significant uncertainty related to the insurance coverage and reimbursement of newly approved products. Third-party payors often rely upon Medicare coverage policy and payment limitations in setting their own reimbursement policies, but also have their own methods and approval process apart from Medicare coverage and reimbursement determinations. It is difficult to predict what third-party payors will decide with respect to coverage and reimbursement for new drug and biologic product candidates. An inability

to promptly obtain coverage and adequate reimbursement rates from both government-funded and private payors for any approved products could have a material adverse effect on a pharmaceutical manufacturer's operating results, ability to raise capital needed to commercialize products and overall financial condition.

Reimbursement may impact the demand for, and/or the price of, any product which obtains marketing approval. Even if coverage is obtained for a given product by a third-party payor, the resulting reimbursement payment rates may not be adequate or may require co-payments that patients find unacceptably high. Patients who are prescribed medications for the treatment of their conditions, and their prescribing physicians, generally rely on third-party payors to reimburse all or part of the costs associated with those medications. Patients are unlikely to use products unless coverage is provided and reimbursement is adequate to cover all or a significant portion of the cost of the products. Therefore, coverage and adequate reimbursement is critical to new product acceptance. Coverage decisions may depend upon clinical and economic standards that disfavor new drug products when more established or lower cost therapeutic alternatives are already available or subsequently become available.

The U.S. government, state legislatures and foreign governmental entities have shown significant interest in implementing cost containment programs to limit the growth of government-paid healthcare costs, including price controls, restrictions on reimbursement and coverage and requirements for substitution of generic products for branded prescription drugs. Adoption of government controls and measures and tightening of restrictive policies in jurisdictions with existing controls and measures, could exclude or limit our products from coverage and limit payments for pharmaceuticals.

In addition, it is expected that the increased emphasis on managed care and cost containment measures in the United States by third-party payors and government authorities will continue and place further pressure on pharmaceutical pricing and coverage. Coverage policies and third-party reimbursement rates may change at any time. Even if favorable coverage and reimbursement status is attained for one or more drug products that gain regulatory approval, less favorable coverage policies and reimbursement rates may be implemented in the future.

## **Employees**

As of December 31, 2021, we had 34 employees, and engaged several consultants as needed to support our operations compared with 33 employees as of December 31, 2020. None of our employees are covered by a collective bargaining agreement. We consider our relationship with our employees to be good.

## **Our Corporate Information**

We were formed under the name "Aridis, LLC" in the State of California on April 24, 2003 as a limited liability company. On August 30, 2004, we changed our name to "Aridis Pharmaceuticals, LLC." On May 21, 2014, we converted into a Delaware corporation named "Aridis Pharmaceuticals, Inc." Our fiscal year end is December 31. Our principal executive offices are located at 983 University Avenue, Building B, Los Gatos, California 95032. Our telephone number is (408) 385-1742. Our website address is [www.aridispharma.com](http://www.aridispharma.com). The information contained on, or that can be accessed through, our website is not a part of this Annual Report.

We have proprietary rights to a number of trademarks used in this prospectus which are important to our business. Solely for convenience, the trademarks and trade names in this prospectus are referred to without the ® and TM symbols, but such references should not be construed as any indicator that their respective owners will not assert, to the fullest extent under applicable law, their rights thereto. All other trademarks, trade names and service marks appearing in this prospectus are the property of their respective owners.

## **Item 1A. Risk Factors**

*You should carefully consider the risks described below, as well as general economic and business risks and the other information in this Annual Report on Form 10-K. The occurrence of any of the events or circumstances described below or other adverse events could have a material adverse effect on our business, results of operations and financial condition and could cause the trading price of our common stock to decline. Additional risks or uncertainties not presently known to us or that we currently deem immaterial may also harm our business.*

*An investment in our common stock involves a high degree of risk. You should give careful consideration to the following risk factors, in addition to the other information included in this prospectus, including our consolidated financial statements and related notes, before deciding whether to invest in shares of our common stock. The occurrence of any of the adverse developments described in the following risk factors could materially and adversely harm our business, financial condition, results of operations or prospects. In that case, the trading price of our common stock could decline, and you may lose all or part of your investment.*

### **Risks Relating to Our Financial Position and Need for Additional Capital**

***We expect to continue to incur net losses for the foreseeable future, and we may never achieve or maintain profitability.***

We are a clinical-stage biopharmaceutical company with a limited operating history. Investment in biopharmaceutical product development is highly speculative because it entails substantial upfront capital expenditures and significant risk that any potential product candidate will fail to demonstrate adequate effect or an acceptable safety profile, gain regulatory approval and become commercially viable. We have no products approved for commercial sale and have not generated any revenue from product sales to date, and we continue to incur significant research and development and other expenses related to our ongoing operations. As a result, we are not profitable and have incurred losses in each period since our inception. For the year ended December 31, 2021, we reported a net loss of approximately \$42.2 million. As of December 31, 2021, we had an accumulated deficit of \$165.3 million.

To become and remain profitable, we or our partners must succeed in developing our product candidates, obtaining regulatory approval for them, and manufacturing, marketing and selling those products for which we or our partners may obtain regulatory approval. We or they may not succeed in these activities, and we may never generate revenue from product sales that is significant enough to achieve profitability. Because of the numerous risks and uncertainties associated with biopharmaceutical product development and commercialization, we are unable to accurately predict the timing or amount of future expenses or when, or if, we will be able to achieve or maintain profitability. Currently, we have no products approved for commercial sale, and to date we have not generated any product revenue. We have financed our operations primarily through the sale of equity securities, upfront payments pursuant to collaboration and license agreements, government grants and capital lease and equipment financing. The size of our future net losses will depend, in part, on the rate of growth or contraction of our expenses and the level and rate of growth, if any, of our revenues. Our ability to achieve profitability is dependent on our ability, alone or with others, to complete the development of our products successfully, obtain the required regulatory approvals, manufacture and market our proposed products successfully or have such products manufactured and marketed by others, and gain market acceptance for such products. There can be no assurance as to whether or when we will achieve profitability.

***Our consolidated financial statements include an explanatory paragraph that expresses substantial doubt about our ability to continue as a going concern, indicating the possibility that we may not be able to operate in the future.***

Primarily as a result of our losses incurred to date, our expected continued future losses, and limited cash balances, we have included disclosure in our consolidated financial statements expressing substantial doubt about our ability to continue as a going concern. Our ability to continue as a going concern is contingent upon, among other factors, the sale of the shares of our common stock or obtaining alternate financing.

***Available cash resources may be insufficient to provide for our working capital needs beyond the next twelve months.***

We expect to continue to incur losses for the foreseeable future and will have to raise additional capital to fund our planned operations and to meet our long-term business objectives. As a result, there is substantial doubt about our ability to continue as a going concern unless we are able to successfully raise additional capital. Until we can generate significant cash from operations, including product and assay revenues, we expect to continue to fund our operations with the proceeds from offerings of our equity securities or debt, or transactions involving product development, technology licensing or collaboration. We can provide no assurances that any sources of a sufficient amount of financing will be available to us on favorable terms, if at all. Failure to raise additional capital in sufficient amounts would significantly impact our ability to continue as a going concern. The actual amount of funds that we will need and the timing of any such investment will be determined by many factors, some of which are beyond our control.

***We will require substantial additional capital in the future. If additional capital is not available, we will have to delay, reduce or cease operations.***

Developing pharmaceutical products, including conducting preclinical studies and clinical trials, is expensive. Development of our product candidates will require substantial additional funds to conduct research, development and clinical trials necessary to bring such product candidates to market and to establish manufacturing, marketing and distribution capabilities. We expect our development expenses to substantially increase in connection with our ongoing activities, particularly as we advance our clinical programs. Our future capital requirements will depend on many factors, including, among others:

- the scope, rate of progress, results and costs of our preclinical and non-clinical studies, clinical trials and other research and development activities;
- the scope, rate of progress and costs of our manufacturing development and commercial manufacturing activities;
- the cost, timing and outcomes of regulatory proceedings, including FDA review of any Biologics License Application, or BLA, or New Drug Application, or NDA, that we file;
- payments required with respect to development milestones we achieve under our in-licensing agreements, including any such payments to University of Chicago, University of Iowa, Brigham and Women's Hospital, Inc., Brigham Young University, Public Health Service and Kenta Biotech Ltd., Massachusetts Institute of Technology-Broad Institute, University of Alabama at Birmingham Research Foundation, and Medimmune Ltd.;
- the costs involved in preparing, filing, prosecuting, maintaining and enforcing patent claims;
- the costs associated with commercializing our product candidates, if they receive regulatory approval;
- the cost and timing of establishing sales and marketing capabilities;
- competing technological efforts and market developments;
- changes in our existing research relationships;
- our ability to establish collaborative arrangements to the extent necessary;
- revenues received from any future products;
- the ability to achieve and receive milestone payments for products licensed to collaborators; and
- payments received under any future strategic collaborations.

We anticipate that we will continue to generate significant losses for the next several years as we incur expenses to complete our clinical trial programs for our product candidates, build commercial capabilities, develop our pipeline and expand our corporate infrastructure. There is a risk of delay or failure at any stage of developing a product candidate, and the time required and costs involved in successfully accomplishing our objectives cannot be accurately predicted. Actual drug research and development costs could substantially exceed budgeted amounts, which could force us to delay, reduce the scope of or eliminate one or more of our research or development programs. Additionally, if the Cystic Fibrosis Foundation does not continue to provide funding support, we may not be able to complete the Phase 1/2a clinical trial relating to AR-501. Furthermore, if the European Commission's IMI (Innovative Medicines Initiative) does not continue to provide support, we may not be able to complete the Phase 3 clinical trial relating to AR-320.

We may never be able to generate a sufficient amount of product revenue to cover our expenses. Until we do, we expect to seek additional funding through public or private equity or debt financings, collaborative relationships, license agreements, capital lease transactions or other available financing transactions. However, there can be no assurance that additional financing will be available on



acceptable terms, if at all, and such financings could be dilutive to existing security holders. Moreover, in the event that additional funds are obtained through arrangements with collaborators, such arrangements may require us to relinquish rights to certain of our technologies, product candidates or products that we would otherwise seek to develop or commercialize ourselves.

If adequate funds are not available, we may be required to delay, reduce the scope of or eliminate one or more of our research or development programs. Our failure to obtain adequate financing when needed and on acceptable terms would have a material adverse effect on our business, financial condition and results of operations.

### **Risks Relating to Clinical Development and Commercialization of Our Product Candidates**

***If we fail to successfully complete clinical trials, fail to obtain regulatory approval or fail to successfully commercialize our product candidates, our business would be harmed and the value of our securities would decline.***

We must be evaluated in light of the uncertainties and complexities affecting a pre-commercial biopharmaceutical company. We have not completed clinical development for any of our product candidates. Our four lead product candidates are AR-301, AR-501 and AR-101, and AR-701. We initiated a Phase 3 pivotal trial of AR-301 in VAP patients, AR-501 is in Phase 1/2a clinical testing and AR-101 is ready for Phase 2/3 pivotal testing. We are planning to initiate both a Phase 3 clinical trial for AR-320 and a Phase 1/2 clinical trial for AR-701 in the second half of 2022. We cannot be assured that our planned clinical development for our product candidates will be completed in a timely manner, or at all, or that we, or any future partner, will be able to obtain approval for our product candidates from the FDA or any foreign regulatory authority.

Regulatory agencies, including the FDA must approve our product candidates before they can be marketed or sold. The approval process is lengthy, requires significant capital expenditures, and is uncertain as to outcome. Our ability to obtain regulatory approval of any product candidate depends on, among other things, completion of additional clinical trials, whether our clinical trials demonstrate statistically significant efficacy with safety issues that do not potentially outweigh the therapeutic benefit of the product candidates, and whether the regulatory agencies agree that the data from our future clinical trials are sufficient to support approval for any of our product candidates. The final results of our current and future clinical trials may not meet FDA or other regulatory agencies' requirements to approve a product candidate for marketing, and the regulatory agencies may otherwise determine that our manufacturing processes or facilities are insufficient to support approval. We, and our current and potential future collaborators, may need to conduct more clinical trials than we currently anticipate. Even if we do receive FDA or other regulatory agency approval, we or our collaborators may not be successful in commercializing approved product candidates. If any of these events occur, our business could be materially harmed and the value of our securities would decline.

***We, or our collaborators, may face delays in completing our clinical trials, and may not be able to complete them at all.***

Clinical trials necessary to support an application for approval to market any of our product candidates have not been completed. Our, or our collaborators', current and future clinical trials may be delayed, unsuccessful, or terminated as a result of many factors, including, but not limited to:

- delays in reaching agreement on trial design and clinical study protocol with investigators and regulatory authorities in various countries where our clinical trials are being conducted;
- governmental or regulatory delays, failure to obtain regulatory approval or changes in regulatory requirements, policy or guidelines;
- adding new clinical trial sites;
- reaching agreement on acceptable terms with prospective contract research organizations, or CROs, and clinical trial sites, the terms of which can be subject to extensive negotiation and may vary significantly among different CROs and trial sites;
- the actual performance of CROs and clinical trial sites in ensuring the proper and timely conduct of our clinical trials;
- developing and validating companion diagnostics on a timely basis;

## [Table of Contents](#)

- adverse effects experienced by subjects in clinical trials;
- manufacturing sufficient quantities of product candidates for use in clinical trials;
- delay or failure in achieving study efficacy endpoints and completing data analysis for a trial;
- regulators or institutional review boards, or IRBs, may not authorize us to commence a clinical trial;
- regulators or IRBs may suspend or terminate clinical research for various reasons, including noncompliance with regulatory requirements or concerns about patient safety;
- we may suspend or terminate our clinical trials if we believe that they expose the participating patients to unacceptable health risks;
- patients may not complete clinical trials due to safety issues, side effects, such as injection site discomfort, a belief that they are receiving placebo instead of our product candidates, or other reasons;
- patients with serious diseases included in our clinical trials may die or suffer other adverse medical events for reasons that may not be related to our product candidates;
- in those trials where our product candidate is being tested in combination with one or more other therapies, deaths may occur that may be attributable to the other therapies;
- we may have difficulty in maintaining contact with patients after treatment, preventing us from collecting the data required by our study protocol;
- product candidates may demonstrate a lack of efficacy during clinical trials;
- personnel conducting clinical trials may fail to properly administer our product candidates;
- COVID-19 pandemic may be protracted and cause a significant decline in patient enrollment rate; and
- our collaborators may decide not to pursue further clinical trials.

Our estimate that the AR-301 Phase 3 study is a 90% power study is based on an assumed 20% effect size. If the actual effect size is less than 20%, the probability that we reach statistical significance would be reduced to a level lower than 90%, which may negatively affect the approval process for AR-301.

In addition, we rely on academic institutions, medical institutions, physician practices and CROs to conduct, supervise or monitor some or all aspects of clinical trials involving our product candidates. We have less control over the timing and other aspects of these clinical trials than if we conducted the monitoring and supervision entirely on our own. Third parties may not perform their responsibilities for our clinical trials on our anticipated schedule or consistent with a clinical trial protocol or applicable regulations. We also may rely on CROs to perform our data management and analysis. They may not provide these services as required or in a timely or compliant manner, and we may be held legally responsible for any or all of their performance failures or inadequacies.

If we or our collaborators experience delays in the completion of, or termination of, any clinical trial of our product candidates, the commercial prospects of our product candidates will be harmed, and our ability to generate product revenues from any of these product candidates will be delayed or eliminated. In addition, any delays in completing our clinical trials will increase our costs, slow our product candidate development and approval process, and jeopardize our ability to commence product sales and generate revenues. Any of these occurrences may harm our business, financial condition and prospects. In addition, many of the factors that cause, or lead to, a delay in the commencement or completion of clinical trials may also lead to the denial of regulatory approval of our product candidates.

***Our development of a COVID-19 therapeutic candidate is at an early stage and we may not be able to successfully develop an effective therapeutic to treat COVID-19 in a timely manner, if at all.***

Various government entities, including the U.S. government, are offering incentives, grants, and contracts to encourage additional investment by commercial organizations into preventative and therapeutic agents against COVID-19, and this may have the effect of increasing the number of competitors and/or providing advantages to known competitors. We are aware of a substantial number of companies, individuals and institutions working to develop a treatment for COVID-19, many of which have substantially greater financial, scientific, and other resources than us, and another party may be successful in producing an effective treatment against COVID-19 before we do. The rapid expansion of development programs directed at COVID-19 may also generate a scarcity of manufacturing capacity among contract research organizations that provide cGMP materials for development and commercialization of biopharmaceutical products.

We are committing financial resources to the development of a monoclonal antibody treatment for COVID-19, which may cause delays in or otherwise negatively impact our other development programs. Similarly resources committed to other development programs may negatively impact the financial resources available for our COVID-19 therapeutic development. In addition, our management and scientific teams have dedicated substantial efforts to our COVID-19 therapeutic development. As of the date of this report, we have 34 employees, which may make us more reliant on our individual employees and on outside contractors than companies with a greater number of employees. If we fail to attract and retain management and scientific personnel, we may be unable to successfully produce, develop and commercialize our therapeutic candidates.

In addition, any success in preclinical testing we might observe for our COVID-19 therapeutic candidate may not be predictive of the results of later-stage human clinical trials. Factors such as safety, efficacy and adverse events can emerge at any time in clinical testing and have the potential to have adverse consequences for our ability to proceed with clinical trials. Other factors such as the emergence of new SARS-CoV-2 mutant virus variants rendering a reduction or complete loss of binding or neutralization by the mAbs, manufacturing challenges, availability of raw materials, and slow-downs in the global supply chain may delay or prevent us from receiving regulatory approval of our therapeutic candidate or, if we do receive regulatory approval, prevent a successful product launch. We may not be successful in developing a therapeutic, or another party may be successful in producing a more efficacious vaccine or other treatment for COVID-19.

***If we encounter difficulties enrolling patients in our clinical trials, our clinical trials could be delayed or otherwise adversely affected.***

Clinical trials for our product candidates require us to identify and enroll a large number of patients with the disease under investigation. We may not be able to enroll a sufficient number of patients with required or desired characteristics to conduct our clinical trials in a timely manner, if at all. Patient enrollment is affected by factors including, but not limited to:

- severity of the disease under investigation;
- design of the trial protocol;
- the size and nature of the patient population;
- eligibility criteria for the study in question;
- lack of a sufficient number of patients who meet the enrollment criteria for our clinical trials;
- delays in characterizing a patient's infection to allow us to select a product candidate, which may lead patients to seek to enroll in other clinical trials or seek alternative treatments;
- perceived risks and benefits of the product candidate under study;
- availability of competing therapies and clinical trials;
- efforts to facilitate timely enrollment in clinical trials;

- clinical trial sites being overtaxed by treating COVID-19 patients;
- scheduling conflicts with participating clinicians;
- patient referral practices of physicians;
- the ability to monitor patients adequately during and after treatment; and
- proximity and availability of clinical trial sites for prospective patients.

The COVID-19 pandemic continues to impact on clinical trial enrollment worldwide. We have experienced slower enrollment of patients in our clinical trials due to the pace in which clinical sites were being initiated for enrollment and may experience similar difficulties in the future. In addition, AR-301 and AR-101 have been granted orphan drug designation for the treatment of *P. aeruginosa* and *S. aureus* in the EU, respectively, and the low prevalence of such diseases relative to the total population may make it harder to identify patients to enroll. If we have difficulty enrolling a sufficient number or diversity of patients to conduct our clinical trials as planned, we may need to delay or terminate ongoing or planned clinical trials, either of which would have an adverse effect on our business.

***Our product candidates are based on a novel technology, which may raise development issues we may not be able to resolve, regulatory issues that could delay or prevent approval, or personnel issues that may keep us from being able to develop our product candidates.***

Our product candidates are based on our mAb technology and gallium-based anti-infective platforms. There can be no assurance that development problems related to our novel technologies will not arise in the future that will cause significant delays or that we will not be able to resolve.

Regulatory approval of novel product candidates such as ours can be more expensive and take longer than for other, more well-known or extensively studied pharmaceutical or biopharmaceutical product candidates due to our and regulatory agencies' lack of experience with them. We believe three mAbs have been approved by the FDA to date, and four other mAbs have received Emergency Use Authorization (for COVID-19 treatment). The approved mAbs are Synagis® which stimulates the immune system to target a viral infection, Anthim® which treats inhalational anthrax in combination with appropriate antibiotics, and ZINPLAVA® to reduce recurrence of *Clostridium difficile* infections. The novelty of our platform may lengthen the regulatory review process, require us to conduct additional studies or clinical trials, increase our development costs, lead to changes in regulatory positions and interpretations, delay or prevent approval and commercialization of our product candidates or lead to significant post-approval limitations or restrictions. For example, the FDA could require additional studies that may be difficult or impossible to perform.

The novel nature of our product candidates also means that fewer people are trained in or experienced with product candidates of this type, which may make it difficult to find, hire and retain capable personnel, particularly for research, development, commercialization and manufacturing positions. For example, study personnel may administer the wrong version of our product candidates or assign study therapy to the wrong treatment group, resulting in potential disqualification of subjects from data analysis. These factors could potentially cause a trial to fail for a reason unrelated to the efficacy of our product candidates. If we are unable to hire and retain the necessary personnel, the rate and success at which we can develop and commercialize product candidates will be limited. Any such events would increase our costs and could delay or prevent our ability to commercialize our product candidates, which could adversely impact our business, financial condition and results of operations.

***If we are unable to successfully develop companion diagnostics for our therapeutic product candidates, or experience significant delays in doing so, we may not realize the full commercial potential of our product candidates.***

We intend to use rapid diagnostic tests of patients' respiratory samples to target our mAb product candidates to those patients we believe are infected with the bacterial agents which our mAb will act against. However, currently there is no commercially available companion diagnostic for AR-101 and AR-401. Therefore, there is a risk that a companion diagnostic for these products are not developed or available to support product launch. The FDA and similar regulatory authorities outside the United States regulate companion diagnostics. Companion diagnostics require separate or coordinated regulatory approval prior to commercialization of the

therapeutic product. Changes to applicable regulations could delay our development programs or delay or prevent eventual marketing approval for our product candidates that may have otherwise been approved.

The FDA's evolving position on the topic of companion diagnostics could affect our clinical development programs that utilize companion diagnostics. In particular, the FDA may limit our ability to use retrospective data, otherwise disagree with our approaches to trial design, biomarker qualification, clinical and analytical validity, and clinical utility, or make us repeat aspects of a trial or initiate new trials.

Assays that can be used as companion diagnostics are commercially available, but in some cases such as for AR-101, they do not yet have regulatory approval for use as companion diagnostic. We have limited experience in the development of diagnostics and may not be successful in developing necessary diagnostics to pair with those product candidates that require a companion diagnostic.

Given our limited experience in developing diagnostics, we expect to rely in part on third parties for their design and manufacture. If we, or any third parties that we engage to assist us, are unable to successfully develop companion diagnostics for our product candidates that require such diagnostics, or experience delays in doing so, the development of our product candidates may be adversely affected, our product candidates may not receive marketing approval and we may not realize the full commercial potential of any products that receive marketing approval. As a result, our business could be materially harmed.

***Clinical development is a lengthy and expensive process with an uncertain outcome, and results of earlier studies and clinical trials may not be predictive of future trial results.***

Clinical testing is expensive and can take many years to complete, and its outcome is inherently uncertain. Failure can occur at any time during the clinical trial process. The results of preclinical studies and early clinical trials of our product candidates may not be predictive of the design or results of later-stage clinical trials. The results regarding initial tolerability and clinical activity generated to date in clinical trials for our AR-301 and AR-101 product candidates in HAP and VAP patients do not ensure that later clinical trials will demonstrate similar results. While we have observed in exploratory analysis statistically significant improvements in the outcomes of some of our clinical trials, many of the improvements we have seen have not reached statistical significance. Statistical significance is a statistical term that means that an effect is unlikely to have occurred by chance. In order to be approved by the FDA, European Medicines Agency, or other drug approving authorities, product candidates must demonstrate that their effect on patients' diseases in the trial is statistically significant and clinically meaningful. Product candidates in later stages of clinical trials may fail to show the desired safety and efficacy traits despite having progressed through preclinical studies and initial clinical trials. Early clinical trials frequently enroll patient populations that are different from the patient populations in later trials, resulting in different outcomes in later clinical trials from those in earlier stage clinical trials. In addition, adverse events may not occur in early clinical trials and only emerge in larger, late-stage clinical trials or after commercialization. Companies in the biopharmaceutical industry have suffered significant setbacks in advanced clinical trials due to lack of efficacy or adverse safety profiles, notwithstanding promising results in earlier clinical trials. If later stage clinical trials do not demonstrate efficacy and safety of our product candidates, we will not be able to market them and our business will be materially harmed.

***We may seek a breakthrough therapy designation for our existing and future product candidates, but we might not receive such designation, and even if we do, such designation may not lead to a faster development or regulatory review or approval process.***

We may seek a breakthrough therapy designation for our existing and future product candidates; however, we cannot assure you our product candidates will meet the criteria for that designation. A breakthrough therapy is defined as a therapy that is intended, alone or in combination with one or more other therapies, to treat a serious condition, and preliminary clinical evidence indicates that the therapy may demonstrate substantial improvement over existing therapies on one or more clinically significant endpoints, such as substantial treatment effects observed early in clinical development. For therapies and biologics that have been designated as breakthrough therapies, interaction and communication between the FDA and the sponsor of the trial can help to identify the most efficient path for clinical development while minimizing the number of patients placed in ineffective control regimens. Therapies designated as breakthrough therapies by the FDA may also be eligible for priority review if supported by clinical data at the time the new drug application is submitted to the FDA.

Designation as a breakthrough therapy is within the discretion of the FDA. Accordingly, even if we believe that one of our product candidates meets the criteria for designation as a breakthrough therapy, the FDA may disagree and instead determine not to make such designation. Even if we receive breakthrough therapy designation, the receipt of such designation for a product candidate

may not result in a faster development or regulatory review or approval process compared to drugs considered for approval under conventional FDA procedures and does not assure ultimate approval by the FDA. In addition, even if one or more of our product candidates qualify as breakthrough therapies, the FDA may later decide that the product candidate no longer meets the conditions for qualification or decide that the time period for FDA review or approval will not be shortened.

***Designation of our product candidates as qualified infectious disease products is not assured and, in any event, even if granted, may not actually lead to a faster development or regulatory review, and would not assure FDA approval of our product candidates.***

We may seek designation of our existing and future product candidates as QIDP. A QIDP is an antibacterial or antifungal drug intended to treat serious or life-threatening infections, including those caused by an antibacterial or antifungal resistant pathogen, including novel or emerging infectious pathogens or certain “qualifying pathogens.” A product designated as a QIDP for a particular indication will also be granted priority review by the FDA and can qualify for fast track status. Upon the approval of an NDA for a drug product designated by the FDA as a QIDP, the product is granted a period of five years of regulatory exclusivity that is in addition to any other period of regulatory exclusivity for which the product is eligible. The FDA has broad discretion whether or not to grant these designations, so even if we believe a particular product candidate is eligible for such designation or status, the FDA could decide not to grant it. Moreover, even if we do receive such a designation, we may not experience a faster development process, review or approval compared to conventional FDA procedures and there is no assurance that our product candidate, even if determined to be a QIDP, will be approved by the FDA.

***Regulatory authorities may not approve our product candidates even if they meet safety and efficacy endpoints in clinical trials.***

The time required to obtain approval by the FDA and comparable foreign authorities is unpredictable but typically takes many years following the commencement of clinical trials and depends upon numerous factors, including the substantial discretion of regulatory authorities. In addition, approval policies, regulations, or the type and amount of clinical data necessary to gain approval may change during the course of a product candidate’s clinical development and may vary among jurisdictions. We have discussions with and obtain guidance from regulatory authorities regarding certain aspects of our clinical development activities. These discussions are not binding commitments on the part of regulatory authorities. Under certain circumstances, regulatory authorities may revise or retract previous guidance during the course of our clinical activities or after the completion of our clinical trials. A regulatory authority may also disqualify a clinical trial in whole or in part from consideration in support of approval of a potential product for commercial sale or otherwise deny approval of that product. Prior to regulatory approval, a regulatory authority may elect to obtain advice from outside experts regarding scientific issues and/or marketing applications under a regulatory authority review. In the United States, these outside experts are convened through the FDA’s Advisory Committee process, which would report to the FDA and make recommendations that may differ from the views of the FDA. Should an Advisory Committee be convened, it would be expected to lengthen the time for obtaining regulatory approval, if such approval is obtained at all.

The FDA and foreign regulatory agencies may delay, limit or deny marketing approval for many reasons, including, but not limited to:

- a product candidate may not be considered safe or effective;
- our manufacturing processes or facilities may not meet the applicable requirements;
- changes in the agencies’ approval policies or adoption of new regulations may require additional work on our part, for example, the FDA may require us to change or expand the endpoints in our clinical trials;
- different divisions of the FDA are reviewing different product candidates and those divisions may have different requirements for approval; and
- changes in regulatory law, FDA or foreign regulatory agency organization, or personnel may result in different requirements for approval than anticipated.

Our product candidates may not be approved even if they achieve their endpoints in clinical trials. Regulatory agencies, including the FDA, or their advisors may disagree with our trial design and our interpretations of data from preclinical studies and clinical trials. Regulatory agencies also may approve a product candidate for fewer or more limited indications than requested or may

grant approval subject to the performance of post-marketing studies. In addition, regulatory agencies may not approve the labeling claims that are necessary or desirable for the successful commercialization of our product candidates. We have not obtained regulatory approval for any product candidate, and it is possible that none of our existing product candidates or any product candidates we may seek to develop in the future will ever obtain regulatory approval.

Any delay in or failure to receive or maintain approval for any of our product candidates could prevent us from ever generating revenues or achieving profitability.

***We may be required to suspend, repeat or terminate our clinical trials if they are not conducted in accordance with regulatory requirements, the results are negative or inconclusive, or the trials are not well designed.***

Clinical trials must be conducted in accordance with FDA regulations governing clinical studies, or other applicable foreign government guidelines, and are subject to oversight by the FDA, other foreign governmental agencies and IRBs/Ethic Committees at the medical institutions where the clinical trials are conducted. In addition, clinical trials must be conducted with product candidates produced under current Good Manufacturing Practices, or cGMP, and may require large numbers of test subjects. Clinical trials may be suspended by the FDA, other foreign governmental agencies or us for various reasons, including, but not limited to:

- deficiencies in the conduct of the clinical trials, including failure to conduct the clinical trial in accordance with regulatory requirements or clinical protocols;
- deficiencies in the clinical trial operations or trial sites;
- the product candidate may have unforeseen adverse side effects;
- the time required to determine whether the product candidate is effective may be longer than expected;
- deaths or other adverse events arising during a clinical trial due to medical problems that may not be related to clinical trial treatments;
- the product candidate may not appear to be more effective than current therapies;
- the quality or stability of the product candidate may fall below acceptable standards; and
- insufficient quantities of the product candidate might be available to complete the trials.

In addition, changes in regulatory requirements and guidance may occur and we may need to amend clinical trial protocols to reflect these changes. Amendments may require us to resubmit our clinical trial protocols to IRBs for reexamination, which may impact the costs, timing or successful completion of a clinical trial. Due to these and other factors, our product candidates could take longer to gain regulatory approval than we expect or we may never gain approval for any product candidates, which could reduce or eliminate our revenue by delaying or terminating the commercialization of our product candidates.

***A Fast Track product designation or other designation to facilitate product candidate development may not lead to faster development or regulatory review or approval process, and it does not increase the likelihood that our product candidates will receive marketing approval.***

We have received a Fast Track product designation for AR-301 and AR-101 and we may seek Fast Track designation for other of our current or future product candidates. Receipt of a designation to facilitate product candidate development is within the discretion of the FDA. Accordingly, even if we believe one of our product candidates meets the criteria for a designation, the FDA may disagree. In any event, the receipt of such a designation for a product candidate may not result in a faster development process, review, or approval compared to drugs considered for approval under conventional FDA procedures and does not assure ultimate marketing approval by the FDA. In addition, the FDA may later decide that the products no longer meet the designation conditions.

***We may not be able to maintain orphan drug marketing exclusivity for our AR-101 and AR-301 product candidates in the United States and/or the European Union, and orphan drug marketing exclusivity may not be available for any of our other product candidates.***

Under the Orphan Drug Act, the FDA may grant orphan drug designation to a drug or biologic intended to treat a rare disease or condition (with a population of less than 200,000), which is defined as one occurring in a patient population of fewer than 200,000 in the United States, or a patient population greater than 200,000 in the U.S. where there is no reasonable expectation that the cost of developing the drug or biologic will be recovered from sales in the United States. In the EU, following the opinion of the EMA's Committee for Orphan Medicinal Products, the European Commission grants orphan drug designation to a product if (1) it is intended for the diagnosis, prevention or treatment of a life-threatening or chronically debilitating condition; (2) either (a) such condition affects no more than five in 10,000 persons in the EU when the application is made, or (b) the product, without the incentives derived from orphan medicinal product status, would not generate sufficient return in the EU to justify investment; and (3) there exists no satisfactory method of diagnosis, prevention or treatment of such condition authorized for marketing in the EU, or if such a method exists, the product will be of significant benefit to those affected by the condition.

Generally, if a drug with an orphan drug designation subsequently receives the first marketing approval for the indication for which it has such designation, the drug is entitled to a period of marketing exclusivity, which precludes the FDA or the European Commission and the competent authorities in the EU Member States from approving another marketing application for the same drug (or similar medicinal product in the European Union) for that time period, except in limited circumstances. The applicable period is seven years in the U.S. and 10 years in the EU. The EU exclusivity period can be reduced to six years if a drug no longer meets the criteria for orphan drug designation or if the drug is sufficiently profitable that market exclusivity is no longer justified. Orphan drug exclusivity may be lost if the FDA determines that the request for designation was materially defective or if the manufacturer is unable to assure sufficient quantity of the drug to meet the needs of patients with the rare disease or condition.

We have been granted orphan drug designation for our AR-101 and AR-301 drug candidates in the European Union, as well as orphan drug designation for our AR-101 drug candidate in the U.S. Although we may apply for orphan drug designation for other product candidates, we may develop in both the U.S. and EU, applicable regulatory authorities may not grant us this designation. In addition, even if such status is obtained for any other product candidate that we may develop, that exclusivity may not effectively protect the candidate from competition because other drugs, such as those with different active ingredients or molecular structures, can be approved for the same condition. Furthermore, even after an orphan drug is approved, the FDA can subsequently approve another drug for the same condition if the FDA concludes that the later drug is clinically superior, in that it is shown to be safer, more effective or makes a major contribution to patient care. In the EU, a marketing authorization may be granted to a similar product during the 10-year period of market exclusivity for the same therapeutic indication at any time if:

- the second applicant can establish in its application that its product, although similar to the orphan medicinal product already authorized, is safer, more effective or otherwise clinically superior;
- the holder of the marketing authorization for the original orphan medicinal product consents to a second orphan medicinal product application; or
- the holder of the marketing authorization for the original orphan medicinal product cannot supply enough orphan medicinal product.

Any inability to secure orphan drug designation or to maintain the exclusivity benefits of this designation could have an adverse impact on our ability to develop and commercialize our product candidates, depending on the extent to which we would be protected by other patents and regulatory exclusivities, and may adversely affect our business, prospects, financial condition and results of operations.

***Any product candidate for which we, or our collaborators, obtain marketing approval could be subject to restrictions or withdrawal from the market, and we may be subject to penalties if we fail to comply with regulatory requirements or if we experience unanticipated problems with our products, when and if any of them are approved.***

Any product candidate that we, or our collaborators, obtain marketing approval for, along with the manufacturing processes, post-approval clinical data, labeling, advertising and promotional activities for such product, will be subject to continuing requirements of the FDA and other regulatory authorities. These requirements include submissions of safety and other post-marketing information,



reports, facility registration and product listing requirements, cGMP requirements relating to quality control, quality assurance and corresponding maintenance of records and documents, requirements regarding the distribution of samples to physicians and recordkeeping. Even if marketing approval of a product candidate is granted, the approval may be subject to limitations on the indicated uses for which the product may be marketed or to conditions of approval or contain requirements for costly post-marketing testing and surveillance to monitor the safety or efficacy of the product. The FDA closely regulates the post-approval marketing and promotion of drugs to ensure drugs are marketed only for the approved indications and in accordance with the provisions of the approved labeling. The FDA imposes stringent restrictions on manufacturers' communications regarding off-label use. If we market our products outside of their approved indications, we will be subject to enforcement action for off-label marketing.

In addition, later discovery of previously unknown problems with these products, manufacturers or manufacturing processes, or failure to comply with regulatory requirements, may yield various results, including, but not limited to:

- restrictions on such products, manufacturers or manufacturing processes;
- restrictions on the labeling or marketing of a product;
- restrictions on product distribution or use;
- requirements to conduct post-marketing clinical trials;
- warning or untitled letters;
- withdrawal of the products from the market;
- refusal to approve pending applications or supplements to approved applications that we submit;
- recall of products, fines, restitution or disgorgement of profits or revenue;
- suspension or withdrawal of marketing approvals;
- refusal to permit the import or export of our products;
- product seizure; and
- injunctions or the imposition of civil or criminal penalties.

The FDA's policies may change and additional government regulations may be enacted that could prevent, limit or delay regulatory approval of our product candidates. If we, or our collaborators, are slow or unable to adapt to changes in existing requirements or the adoption of new requirements or policies, or if we, or our collaborators, are not able to maintain regulatory compliance, any marketing approval that was obtained could be lost, which would adversely affect our business, prospects and ability to achieve or sustain profitability.

***If we, or our collaborators, are unable to comply with foreign regulatory requirements or obtain foreign regulatory approvals, our ability to develop foreign markets for our products could be impaired.***

Sales of our products outside the U.S. will be subject to foreign regulatory requirements governing clinical trials, marketing approval, manufacturing, product licensing, pricing and reimbursement. These regulatory requirements vary greatly from country to country. As a result, the time required to obtain approvals outside the U.S. may differ from that required to obtain FDA approval and we may not be able to obtain foreign regulatory approvals on a timely basis or at all. Approval by the FDA does not ensure approval by regulatory authorities in other countries, and approval by one foreign regulatory authority does not ensure approval by regulatory authorities in other countries or by the FDA and foreign regulatory authorities could require additional testing. Failure to comply with these regulatory requirements or obtain required approvals could impair our ability to develop foreign markets for our products.

***We are subject to U.S. and certain foreign export and import controls, sanctions, embargoes, anti-corruption laws, and anti-money laundering laws and regulations. Compliance with these legal standards could impair our ability to compete in domestic and international markets. We can face criminal liability and other serious consequences for violations, which can harm our business.***

We are subject to export control and import laws and regulations, including the U.S. Export Administration Regulations, U.S. Customs regulations, various economic and trade sanctions regulations administered by the U.S. Treasury Department's Office of Foreign Assets Controls, the U.S. Foreign Corrupt Practices Act of 1977, as amended, or FCPA, the U.S. domestic bribery statute contained in 18 U.S.C. § 201, the U.S. Travel Act, the USA PATRIOT Act, and other state and national anti-bribery and anti-money laundering laws in the countries in which we conduct activities. Anti-corruption laws are interpreted broadly and prohibit companies and their employees, agents, contractors, and other collaborators from authorizing, promising, offering, or providing, directly or indirectly, improper payments or anything else of value to recipients in the public or private sector. We may engage third parties for clinical trials outside of the United States, to sell our products abroad once we enter a commercialization phase, and/or to obtain necessary permits, licenses, patent registrations, and other regulatory approvals. We have direct or indirect interactions with officials and employees of government agencies or government-affiliated hospitals, universities, and other organizations. We can be held liable for the corrupt or other illegal activities of our employees, agents, contractors, and other collaborators, even if we do not explicitly authorize or have actual knowledge of such activities. Any violations of the laws and regulations described above may result in substantial civil and criminal fines and penalties, imprisonment, the loss of export or import privileges, debarment, tax reassessments, breach of contract and fraud litigation, reputational harm, and other consequences.

***Our business may be adversely impacted by the consequences of Russia's invasion of Ukraine.***

Economic, political and social conditions resulting from Russia's invasion of Ukraine could materially disrupt our clinical trials, increase our costs and may disrupt planned clinical development activities. For example, our AR-301 clinical trial currently has sites enrolling in Russia, Ukraine and Belarus. To the extent the conflict between Ukraine and Russia adversely impacts our ability to enroll patients or complete enrollments in process or adversely impacts the ability of our suppliers to produce and distribute the supplies we need for our AR-301 clinical trial, the timing for completing our AR-301 trial may be adversely impacted. In addition, the United States, United Kingdom and European Union governments, among others, have instituted various sanctions and export-control measures in response to the invasion, including comprehensive financial sanctions, targeted at Russia or designated individuals and entities with business interests and/or government connections to Russia or those involved in Russian military activities. Governments have also enhanced export controls and trade sanctions targeting Russia's imports of goods. The duration and intensity of this conflict and its economic impact on our European operations is uncertain at this time, but it is possible that our business, results of operations and financial condition could be materially and adversely affected.

***Developing product candidates in combination with other therapies may lead to unforeseen side effects or failures in our clinical trials.***

We, and our collaborators, are studying our product candidates in clinical trials in combination with approved therapies, including antibiotics, and we anticipate that if any product candidates are approved for marketing, they will be approved to be used only in combination with other therapies. Our development programs and planned studies carry all the risks inherent in drug development activities, including the risk that they will fail to demonstrate meaningful efficacy or acceptable safety. In addition, our development programs are subject to additional regulatory, commercial, manufacturing and other risks because of the use of other therapies in combination with our product candidates. For example, the other therapies may lead to toxicities that are improperly attributed to our product candidates or the combination of our product candidates with other therapies may result in toxicities that the product candidate or other therapy does not produce when used alone. The other therapies we are using in combination with our product candidates may be removed from the market or become prohibitively expensive and thus be unavailable for testing or commercial use with any of our approved products. Testing product candidates in combination with other therapies may increase the risk of significant adverse effects or test failures. The timing, outcome and cost of developing products to be used in combination with other therapies is difficult to predict and dependent on a number of factors that are outside our reasonable control. If any safety or toxicity issues arise in these clinical trials or with any approved products, or if the other therapies are removed from the market, the products may not be approved, which could prevent us from ever generating revenues or achieving profitability.

***We will need to develop or acquire additional manufacturing and distribution capabilities, or outsource the same to third parties, in order to commercialize any product candidates that obtain marketing approval, and we may encounter unexpected costs or difficulties in doing so.***

If we independently develop and commercialize one or more of our product candidates, we will need to invest in acquiring or building additional capabilities and effectively manage our operations and facilities to successfully pursue and complete future research, development and commercialization efforts. We will require additional investment and validation process development in order to qualify our commercial-scale manufacturing process to manufacture clinical trial materials and commercial material if any of our products are approved for marketing. This investment and validation process development may be expensive and time-consuming. We will require additional personnel with experience in commercial-scale manufacturing, managing of large-scale information technology systems and managing a large-scale distribution system. We will need to add personnel and expand our capabilities, which may strain our existing managerial, operational, regulatory compliance, financial and other resources. To do this effectively, we must:

- recruit, hire, train, manage and motivate a growing employee base;
- accurately forecast demand for our products;
- assemble and manage the supply chain to ensure our ability to meet demand; and
- expand existing operational, manufacturing, financial and management information systems.

We may seek FDA approval for our production process and facilities simultaneously with seeking approval for sale of our product candidates. Should we not complete the development of adequate manufacturing and distribution capabilities, including manufacturing capacity, or fail to receive timely approval of our manufacturing process and facilities, our ability to supply clinical trial materials for planned clinical trials or supply products following regulatory approval for sale could be delayed, which would further delay our clinical trials or the period of time when we would be able to generate revenues from the sale of such products, if we are even able to obtain approval or generate revenues at all.

Additionally, we may decide to outsource some or all of our manufacturing activities to a third-party commercial manufacturing organization, or CMO. Under any agreement with a CMO, we would have less control over the timing and quality of manufacturing than if we were to perform such manufacturing ourselves. A CMO would be manufacturing other pharmaceutical products in the same facilities as our product candidates, increasing the risk of cross product contamination. Further, there is no guarantee that any CMO will continue ongoing operations, causing potential delays in product supply, reduced revenues and other liabilities for us.

Any such events would increase our costs and could delay or prevent our ability to commercialize our product candidates, which could adversely impact our business, financial condition and results of operations.

***Our product candidates may cause undesirable side effects or have other properties that could delay or prevent their regulatory approval, limit the commercial profile of an approved label, or result in significant negative consequences following marketing approval, if any.***

Undesirable side effects caused by our product candidates could cause us, our collaborators, or regulatory authorities to interrupt, delay or halt clinical trials and could result in a more restrictive label, the delay or denial of regulatory approval by the FDA or other comparable foreign regulatory authorities, or litigation by injured patients, if any. To date, patients treated with AR-301, AR-501 and AR-101 have experienced AEs related to the study drug, some of which have been serious. Regarding AR-301, few (2.2%) adverse events, or AEs, were deemed related, and no serious adverse events, or SAEs, were deemed to be related to AR-301 treatment. There were 31 deaths in the trial, none of which were deemed related to AR-301. Regarding AR-501, there have been a total of 12 AEs reported of which six were related to AR-501 in the ongoing Phase 2a clinical trial. To date, there have been no SAEs and no deaths in this trial. Regarding AR-101, 12 SAEs were experienced by five subjects. An event of cardiorespiratory arrest was judged as probably related to AR-101 and events of hyperbilirubinemia and cholestasis, although pre-existent, were deemed possibly related. In both cases, the causality assessment by the investigators accounted for the fact that a contribution by AR-101 to the AE could not be excluded with certainty although other probable causes were acknowledged. The other SAEs were deemed unrelated. The AR-701 mAbs may exhibit a reduction or complete loss of efficacy due to the emergence of new SARS-CoV-2 mutant virus variants.

Because our product candidates are intended to assist the immune system, our clinical trials could reveal an unacceptable severity and prevalence of side effects, including, but not limited to, adverse immune responses that lead to previously unobserved complications. As a result of any side effects, our clinical trials could be suspended or terminated and the FDA or comparable foreign regulatory authorities could order us to cease further development, or deny approval, of our product candidates for any or all targeted indications. The drug-related side effects could affect patient recruitment or the ability of enrolled patients to complete the trial or result in potential product liability claims. Any of these occurrences may harm our business, financial condition and prospects significantly.

Additionally, if one or more of our product candidates receives marketing approval, and we, our collaborators, or others later identify undesirable side effects caused by such products, a number of potentially significant negative consequences could result, including, but not limited to:

- regulatory authorities may withdraw approvals of such product;
- regulatory authorities may require additional warnings on the label;
- we may be required to create a medication guide outlining the risks of such side effects for distribution to patients;
- we may be sued and held liable for harm caused to patients; and
- our reputation may suffer.

In addition, we cannot assure you that the bacteria which our mAbs target will not in the future develop a resistance to our mAbs.

Any of these events could prevent us from achieving or maintaining market acceptance of the particular product candidate, if approved, and could significantly harm our business, results of operations and prospects.

***If we cannot conduct the non-clinical testing required by regulatory authorities to demonstrate an acceptable toxicity profile for our product candidates in non-clinical studies, we will not be able to initiate or continue clinical trials or obtain approval for our product candidates.***

In order to move a product candidate into human clinical trials, we must first demonstrate an acceptable toxicity profile in preclinical testing. Furthermore, in order to obtain approval, we must also demonstrate safety in various non-clinical tests. We may not have conducted or may not conduct the types of non-clinical testing required by regulatory authorities, or future non-clinical tests may indicate that our product candidates are not safe for use. Preclinical and non-clinical testing is expensive, time-consuming and has an uncertain outcome. In addition, success in initial non-clinical testing does not ensure that later non-clinical testing will be successful. We may experience numerous unforeseen events during, or as a result of, the non-clinical testing process, which could delay or prevent our ability to develop or commercialize our product candidates, including, but not limited to:

- our preclinical and non-clinical testing may produce inconclusive or negative safety results, which may require us to conduct additional non-clinical testing or to abandon product candidates;
- our product candidates may have unfavorable pharmacology or toxicity characteristics;
- our product candidates may cause undesirable side effects such as negative immune responses that lead to complications;
- our enrolled patients may have allergies that lead to complications after treatment; and
- the FDA or other regulatory authorities may determine that additional safety testing is required.

Any such events would increase our costs and could delay or prevent our ability to commercialize our product candidates, which could adversely impact our business, financial condition and results of operations.

***Because we have multiple product candidates in our clinical pipeline and are considering a variety of target indications, we may expend our limited resources to pursue a particular product candidate or indication and fail to capitalize on product candidates or indications that may be more profitable or for which there is a greater likelihood of success.***

Because we have limited financial and managerial resources, we must focus our research and development efforts on those product candidates and specific indications that we believe are the most promising. As a result, we may forego or delay our pursuit of opportunities with other product candidates or other indications that later prove to have greater commercial potential. Our resource allocation decisions may cause us to fail to capitalize on viable commercial products or profitable market opportunities. We may in the future spend our resources on other research programs and product candidates for specific indications that ultimately do not yield any commercially viable products. Furthermore, if we do not accurately evaluate the commercial potential or target market for a particular product candidate, we may relinquish valuable rights to that product candidate through collaboration, licensing or other royalty arrangements in cases in which it would have been more advantageous for us to retain sole development and commercialization rights.

***If we are unable to establish sales and marketing capabilities or enter into agreements with third parties to sell and market our product candidates, we may not be successful in commercializing our product candidates if and when they are approved.***

We do not have a sales and marketing infrastructure or any experience in the sales, marketing or distribution of pharmaceutical products. We may seek additional third-party collaborators for the commercialization of our other product candidates. In the future, we may choose to build a focused sales and marketing infrastructure to market or co-promote some of our product candidates if and when they are approved, which would be expensive and time-consuming. Alternatively, we may elect to outsource these functions to third parties. Either approach carries significant risks. For example, recruiting and training a sales force is expensive and time-consuming and, if done improperly, could delay a product launch and result in limited sales. If the commercial launch of a product candidate for which we recruit a sales force and establish marketing capabilities is delayed or does not occur for any reason, we would have prematurely or unnecessarily incurred these commercialization expenses. This may be costly, and our investment would be lost if we cannot retain or reposition our sales and marketing personnel. Outsourcing sales and marketing capabilities will depend on our ability to enter into and maintain agreements with other companies having sales, marketing and distribution capabilities, the ability of such companies to successfully market and sell our product candidates, and our ability to enter into such agreements on terms favorable to us.

Factors that may inhibit our efforts to commercialize our products on our own include, but are not limited to:

- our inability to recruit, manage and retain adequate numbers of effective sales and marketing personnel;
- the inability of marketing personnel to develop effective marketing materials;
- the inability of sales personnel to obtain access to or persuade adequate numbers of physicians to prescribe any future products;
- the lack of complementary products to be offered by sales personnel, which may put us at a competitive disadvantage relative to companies with more extensive product lines; and
- unforeseen costs and expenses associated with creating an independent sales and marketing organization.

Entry into agreements with third parties to sell and market our product candidates will subject us to a number of risks, including, but not limited to, the following:

- we may be required to relinquish important rights to our products or product candidates;
- we may not be able to control the amount and timing of resources that our distributors or collaborators may devote to the commercialization of our product candidates;
- distributors or collaborators may experience financial difficulties;

- our distributors or collaborators may not devote sufficient time to the marketing and sales of our products; and
- business combinations or significant changes in a collaborator's business strategy may adversely affect a collaborator's willingness or ability to complete its obligations under any arrangement.

***The availability and amount of reimbursement for our product candidates, if approved, and the manner in which government and private payors may reimburse for any potential products, are uncertain.***

Obtaining coverage and reimbursement approval for a product from a government or other third-party payor is a time-consuming and costly process that could require us to provide supporting scientific, clinical and cost effectiveness data for the use of our products to the payor. There may be significant delays in obtaining such coverage and reimbursement for newly approved products, and coverage may be more limited than the purposes for which the product is approved by the FDA or similar regulatory authorities outside of the United States. Moreover, eligibility for coverage and reimbursement does not imply that a product will be paid for in all cases or at a rate that covers our costs, including research, development, intellectual property, manufacture, sale and distribution expenses. Reimbursement rates may vary according to the use of the product and the clinical setting in which it is used, may be based on reimbursement levels already set for lower cost products and may be incorporated into existing payments for other services. Net prices for products may be reduced by mandatory discounts or rebates required by government healthcare programs or private payors and by any future relaxation of laws that presently restrict imports of product from countries where they may be sold at lower prices than in the United States.

There is significant uncertainty related to the insurance coverage and reimbursement of newly approved products. Third-party payors often rely upon Medicare coverage policy and payment limitations in setting their own reimbursement policies, but also have their own methods and approval process apart from Medicare coverage and reimbursement determinations. It is difficult to predict at this time what third-party payors will decide with respect to the coverage and reimbursement for our product candidates. Our inability to promptly obtain coverage and adequate reimbursement rates from both government-funded and private payors for any approved products that we develop could have a material adverse effect on our operating results, our ability to raise capital needed to commercialize products and our overall financial condition.

Reimbursement may impact the demand for, and/or the price of, any product for which we obtain marketing approval. Assuming we obtain coverage for a given product by a third-party payor, the resulting reimbursement payment rates may not be adequate or may require co-payments that patients find unacceptably high. Patients who are prescribed medications for the treatment of their conditions, and their prescribing physicians, generally rely on third-party payors to reimburse all or part of the costs associated with those medications. Patients are unlikely to use our products unless coverage is provided and reimbursement is adequate to cover all or a significant portion of the cost of our products. Therefore, coverage and adequate reimbursement is critical to new product acceptance. Coverage decisions may depend upon clinical and economic standards that disfavor new drug products when more established or lower cost therapeutic alternatives are already available or subsequently become available.

The U.S. government, state legislatures and foreign governmental entities have shown significant interest in implementing cost containment programs to limit the growth of government-paid healthcare costs, including price controls, restrictions on reimbursement and coverage and requirements for substitution of generic products for branded prescription drugs. Adoption of government controls and measures and tightening of restrictive policies in jurisdictions with existing controls and measures, could exclude or limit our products from coverage and limit payments for pharmaceuticals.

In addition, we expect that the increased emphasis on managed care and cost containment measures in the U.S. by third-party payors and government authorities to continue and will place pressure on pharmaceutical pricing and coverage. Coverage policies and third-party reimbursement rates may change at any time. Even if favorable coverage and reimbursement status is attained for one or more drug products for which we receive regulatory approval, less favorable coverage policies and reimbursement rates may be implemented in the future.

***Failure to attract and retain key personnel could impede our ability to develop our products and to obtain new collaborations or other sources of funding.***

Because of the specialized scientific nature of our business and the novel properties of our antibody platform, our success is highly dependent upon our ability to attract and retain qualified scientific and technical personnel, consultants and advisors. We depend

greatly on our founders Dr. Vu Truong, our Chief Executive Officer, Chief Scientific Officer and a Director, and Dr. Eric Patzer, our Executive Chairman. We will also need to recruit a significant number of additional personnel in order to achieve our operating goals and financial reporting obligations. In order to pursue our product development and marketing and sales plans, we will need to hire additional qualified scientific personnel to perform research and development, as well as personnel with expertise in clinical testing, government regulation, manufacturing, marketing and sales, which may strain our existing managerial, operational, regulatory compliance, financial and other resources. We also rely on consultants and advisors to assist in formulating our research and development strategy and adhering to complex regulatory requirements. We face competition for qualified individuals from numerous pharmaceutical and biotechnology companies, universities and other research institutions. There can be no assurance that we will be able to attract and retain such individuals on acceptable terms, if at all. The failure to attract and retain qualified personnel, consultants and advisors could have a material adverse effect on our business, financial condition and results of operations.

***We may expend our limited resources to pursue a particular product candidate or indication and fail to capitalize on product candidates or indications that may be more profitable or for which there is a greater likelihood of success.***

Because we have limited financial and managerial resources, we focus on research programs and product candidates for the indications that we believe are the most scientifically and commercially promising. Our resource allocation decisions may cause us to fail to capitalize on viable scientific or commercial products or profitable market opportunities. In addition, we may spend valuable time and managerial and financial resources on research programs and product candidates for specific indications that ultimately do not yield any scientifically or commercially viable products. If we do not accurately evaluate the scientific and commercial potential or target market for a particular product candidate, we may relinquish valuable rights to that product candidate through collaboration, licensing or other royalty arrangements in situations where it would have been more advantageous for us to retain sole rights to development and commercialization.

### **Risks Relating to Manufacturing Activities**

***We have no experience manufacturing our product candidates at commercial scale, and there can be no assurance that our product candidates can be manufactured in compliance with regulations at a cost or in quantities necessary to make them commercially viable. There can be no assurance that any contract manufacturing facilities will be acceptable for licensure by regulatory authorities or that we can contract to build acceptable facilities.***

We have no experience in commercial-scale manufacturing of mAbs. We may develop our manufacturing capacity in part by building manufacturing facilities. This activity would require substantial additional funds and we would need to hire and train significant numbers of qualified employees to staff these facilities. We may not be able to develop commercial-scale manufacturing facilities that are adequate to produce materials for additional later-stage clinical trials or commercial use. We currently rely on CMOs for bulk product manufacturing and sterile fill and finish of our products, and these contractors currently manufacture our product candidates at a scale that is not adequate for commercial supply. Failure to find and maintain satisfactory commercial-scale manufacturing contractors could impair our ability to supply product for clinical and commercial needs. Additionally, we may decide to outsource some or all of our bulk product manufacturing activities to a third-party CMO. Failure of any of these contractors to maintain compliance with cGMPs and other regulatory and legal requirements could result in government actions that would limit or eliminate clinical trial and commercial product supply. Under any agreement with a CMO, we would have less control over the timing and quality of manufacturing than if we were performing such manufacturing ourselves. A CMO would be manufacturing other pharmaceutical products in the same facilities as our product candidates, increasing the risk of cross product contamination. Further, there is no guarantee that any CMO will continue ongoing operations, causing potential delays in product supply, reduced revenues and other liabilities for us.

The equipment and facilities employed in the manufacture of pharmaceuticals are subject to stringent qualification requirements by regulatory agencies, including validation of equipment, systems and processes. We may be subject to lengthy delays and expense in conducting validation studies, if we can meet the requirements at all.

If we are unable to manufacture or contract for a sufficient supply of our product candidates on acceptable terms, or if we encounter delays or difficulties in our manufacturing processes or our relationships with other manufacturers, our preclinical and clinical testing schedule would be delayed. This in turn would delay the submission of product candidates for regulatory approval and thereby delay the market introduction and subsequent sales of any products that receive regulatory approval, which would have a material adverse effect on our business, financial condition and results of operations. Furthermore, we or our contract manufacturers must supply all necessary documentation in support of our regulatory approval applications on a timely basis and must adhere to cGMP regulations

enforced by the FDA and other regulatory bodies through their facilities inspection programs. If these facilities cannot pass a pre-approval plant inspection, the approval by the FDA or other regulatory bodies of the products will not be granted. If the FDA or a comparable foreign regulatory authority does not approve our facilities and processes for the manufacture of our product candidates or if they withdraw any such approval in the future, we may need to correct the issues or find alternative manufacturing facilities, which would significantly impact our ability to develop, obtain regulatory approval for or market our product candidates, if approved.

***Our contract manufacturers are subject to significant regulation with respect to manufacturing of our products.***

All entities involved in the preparation of a product candidate for clinical trials or commercial sale, including our contract manufacturing organizations used for bulk product manufacturing and filling and finishing of our bulk product, are subject to extensive regulation. Components of a finished product approved for commercial sale or used in late-stage clinical trials must be manufactured in accordance with cGMP. These regulations govern manufacturing processes and procedures, including record keeping, and the implementation and operation of quality systems to control and assure the quality of investigational products and products approved for sale. The facilities and quality systems of some or all of our third-party contractors must pass a pre-approval inspection for compliance with the applicable regulations as a condition of any regulatory approval of our product candidates. In addition, the regulatory authorities may, at any time, audit or inspect a manufacturing facility involved with the preparation of our product candidates or the associated quality systems for compliance with the regulations applicable to the activities being conducted. The regulatory authorities also may, at any time following approval of a product for sale, audit the manufacturing facilities of our third-party contractors or raw material suppliers. If any such inspection or audit identifies a failure to comply with applicable regulations or if a violation of our product specifications or applicable regulations occurs independent of such an inspection or audit, the relevant regulatory authority may require remedial measures that may be costly and time-consuming to implement and that may include the temporary or permanent suspension of a clinical trial or commercial sales or the temporary or permanent closure of a facility. Our third-party contractors or raw material suppliers may refuse to implement remedial measures required by regulatory authorities. Any failure to comply with applicable manufacturing regulations or failure to implement required remedial measures imposed upon third parties with whom we contract could materially harm our business.

***We rely on relationships with third-party contract manufacturers and raw material suppliers, which limits our ability to control the availability of, and manufacturing costs for, our product candidates.***

Problems with any of our contract manufacturers' or raw material suppliers' facilities or processes, could prevent or delay the production of adequate supplies of finished products. This could delay clinical trials or delay and reduce commercial sales and materially harm our business. Any prolonged delay or interruption in the operations of our collaborators' facilities or contract manufacturers' facilities could result in cancellation of shipments, loss of components in the process of being manufactured or a shortfall in availability of a product candidate or products. A number of factors could cause interruptions, including, but not limited to:

- the inability of a supplier to provide raw materials;
- equipment malfunctions or failures at the facilities of our collaborators or suppliers;
- employee absenteeism as a result of coronavirus outbreaks;
- high process failure rates;
- damage to facilities due to natural or man-made disasters;
- changes in regulatory requirements or standards that require modifications to our or our collaborators' and suppliers' manufacturing processes;
- action by regulatory authorities or by us that results in the halting or slowdown of production of components or finished product at our facilities or the facilities of our collaborators or suppliers;
- problems that delay or prevent manufacturing technology transfer to another facility, contract manufacturer or collaborator with subsequent delay or inability to start up a commercial facility;



- a contract manufacturer or supplier going out of business, undergoing a capacity shortfall or otherwise failing to produce product as contractually required;
- employee or contractor misconduct or negligence; and
- shipping delays, losses or interruptions; and other similar factors.

Because manufacturing processes are complex and are subject to a lengthy regulatory approval process, alternative qualified production capacity and sufficiently trained or qualified personnel may not be available on a timely or cost-effective basis or at all. Difficulties or delays in our contract manufacturers' production of drug substances could delay our clinical trials, increase our costs, damage our reputation, and cause us to lose revenue and market share if we are unable to timely meet market demand for any products that are approved for sale.

The manufacturing process for our product candidates has several components that are sourced from a single manufacturer. If we utilize an alternative manufacturer or alternative component, we may be required to demonstrate comparability of the drug product before releasing the product for clinical use and we may not be able to find an alternative supplier. For example, the stoppers used to seal the vials of our products are made by a single supplier using a proprietary formula and process. Any change to the stopper would require us to carry out lengthy studies to verify that our product remains stable with the replacement stopper. The loss of any of our current suppliers could result in manufacturing delays for the component substitution, and we may need to accept changes in terms or price from our existing supplier in order to avoid such delays.

Further, if our contract manufacturers are not in compliance with regulatory requirements at any stage, including post-marketing approval, we may be fined, forced to remove a product from the market and/or experience other adverse consequences, including delays, which could materially harm our business.

***A pandemic, epidemic or outbreak of an infectious disease, such as COVID-19, may materially and adversely affect our business and operations.***

The outbreak of COVID-19 originated in Wuhan, China, in December 2019 and has since spread to multiple countries, including the United States and several European countries. On March 11, 2020, the World Health Organization declared the outbreak a pandemic. The COVID-19 pandemic is affecting the United States and global economies and has affected our operations and those of third parties on which we rely, including by causing disruptions in the supply of our product candidates and the conduct of current and future clinical trials. In addition, the COVID-19 pandemic has affected the operations of the FDA and other health authorities, which has resulted in delays of reviews and approvals, including with respect to our product candidates. The evolving COVID-19 pandemic has impacted the pace of enrollment in our Phase 3 pivotal trial for AR-301 and our Phase 1 clinical trial for AR-501 during 2021 and could possibly extend longer as patients may avoid or may not be able to travel to healthcare facilities and physicians' offices unless due to a health emergency. Such facilities and offices may also be required to focus limited resources on non-clinical trial matters, including treatment of COVID-19 patients, and may not be available, in whole or in part, for clinical trial services related to AR-301 and AR-501 or our other product candidates. Additionally, while the potential economic impact brought by, and the duration of the COVID-19 pandemic is difficult to assess or predict, the impact of the COVID-19 pandemic on the global financial markets may reduce our ability to access capital, which could negatively impact our short-term and long-term liquidity. The ultimate impact of the COVID-19 pandemic is highly uncertain and subject to change. We do not yet know the full extent of potential delays or impacts on our business, financing or clinical trial activities or on healthcare systems or the global economy as a whole. However, these effects could have a material impact on our liquidity, capital resources, operations and business and those of the third parties on which we rely.

***Business disruptions could seriously harm future revenue and financial condition and increase our costs and expenses.***

Our operations, and those of our third-party manufacturers, CROs and other contractors and consultants, could be subject to earthquakes, power shortages, telecommunications failures, water shortages, floods, hurricanes, typhoons, fires, extreme weather conditions, medical epidemics and other natural or man-made disasters or business interruptions, for which we are predominantly self-insured. The occurrence of any of these business disruptions could seriously harm our operations and financial condition and increase our costs and expenses.

Our corporate headquarters are located in Los Gatos, California, an area prone to wildfires and earthquakes. These and other natural disasters could severely disrupt our operations, and have a material adverse effect on our business, results of operations, financial condition and prospects. If a natural disaster, power outage or other event occurred that prevented us from using all or a significant portion of our headquarters, that damaged critical infrastructure, such as the manufacturing facilities of our third-party contract manufacturers, or that otherwise disrupted operations, it may be difficult or, in certain cases, impossible for us to continue our business for a substantial period of time. Any disaster recovery and business continuity plans we have in place may prove inadequate in the event of a serious disaster or similar event. We may incur substantial expenses as a result of the limited nature of our disaster recovery and business continuity plans, which, could have a material adverse effect on our business.

Any disruption in production or inability to produce or ship adequate quantities to meet our needs, whether as a result of a natural disaster or other causes (such as the recent outbreak of the coronavirus), could impair our ability to operate our business on a day-to-day basis and to continue our research and development of our product candidates. In addition, we are exposed to the possibility of product supply disruption and increased costs in the event of changes in the policies of the United States government, political unrest or unstable economic conditions. Any recall of the manufacturing lots or similar action regarding our API used in clinical trials could delay the trials or detract from the integrity of the trial data and its potential use in future regulatory filings. In addition, manufacturing interruptions or failure to comply with regulatory requirements by any of these manufacturers could significantly delay clinical development of potential products and reduce third-party or clinical researcher interest and support of proposed trials. These interruptions or failures could also impede commercialization of our product candidate and impair our competitive position.

***We use and generate hazardous materials in our business and must comply with environmental laws and regulations, which can be expensive.***

Our research, development and manufacturing involve the controlled use of hazardous materials, chemicals, various active microorganisms and volatile organic compounds, and we may incur significant costs as a result of the need to comply with numerous laws and regulations. For example, as a pharmacologically-active material, any residual impurities in process-waste streams must be disposed of as hazardous waste. We are subject to laws and regulations enforced by the FDA, the Drug Enforcement Agency, foreign health authorities and other regulatory requirements, including the Occupational Safety and Health Act, the Toxic Substances Control Act, the Resource Conservation and Recovery Act, and other current and potential federal, state, local and foreign laws and regulations governing the use, manufacture, storage, handling and disposal of our products, materials used to develop and manufacture our product candidates, and resulting waste products. Although we believe that our safety procedures for handling and disposing of such materials, and for killing any unused microorganisms before disposing of them, comply with the standards prescribed by state and federal regulations, the risk of accidental contamination or injury from these materials cannot be completely eliminated. In the event of such an accident, we could be held liable for any damages that result and any such liability could exceed our resources.

***During the course of the product life cycle we will make process changes to scale up manufacturing to commercial manufacture or transfer the production to alternate sites or contract manufacturers. Our ability to successfully implement these changes will depend on our ability to demonstrate, to the satisfaction of the FDA and other regulatory agencies that the product made by the new process or at the new site is comparable to the original product.***

In the event that manufacturing process changes are necessary for the further development of a product candidate, we may not be able to reach agreement with regulatory agencies on the criteria for demonstrating comparability to the original product, which would require us to repeat clinical studies performed with the original product. This could result in lengthy delays in implementing the new process or site and consequent delays in regulatory approval and commercial sales of product derived from the new process. If we reach agreement with regulatory agencies on the criteria for establishing comparability, we may not be able to meet these criteria or may suffer lengthy delays in meeting these criteria. This may result in significant lost sales due to inability to meet commercial demand with the original product. Furthermore, studies to demonstrate comparability, or any other studies on the new process or site such as validation studies, may uncover findings that result in regulatory agencies delaying or refusing to approve the new process or site.

## Risks Relating to Our Joint Venture Agreement

*If our joint venture with Hepalink is not successful or if we fail to realize the benefits we anticipate from such joint venture, we may not be able to capitalize on the full market potential of our products in China, Hong Kong, Macau and Taiwan.*

We entered into a Joint Venture Contract, as amended effective August 6, 2018, or the JV Agreement, with Shenzhen Hepalink Pharmaceutical Group Co., Ltd., a People's Republic of China company, or Hepalink, a related party and significant shareholder in the Company, pursuant to which we formed a Joint Venture company named Shenzhen Arimab BioPharmaceuticals Co., Ltd., or SABC, a People's Republic of China Company, develop, manufacture, import and distribute AR-101, AR-301 and AR-105 in China, Hong Kong, Macau and Taiwan, collectively, referred to as the Territory. The Joint Venture received regulatory approval in China and SABC was formed on July 2, 2018.

Hepalink contributed the equivalent of \$7.2 million in renminbi, the official currency of the People's Republic of China, and owns 51% of the capital of SABC and we contributed (i) \$1.0 million in cash and (ii) a license to AR-101, AR-301 and AR-105 pursuant to an Amended and Restated Technology License and Collaboration Agreement between us and SABC and we own 49% of the capital of SABC. It was agreed by the parties that we shall be reimbursed for certain legal and contract manufacturing expenses related to the clinical drug supply for a Phase 3 clinical study of AR-301 and the clinical drug supply for a clinical study of AR-105. In addition, Hepalink will provide SABC with clinical and regulatory personnel services for clinical and regulatory review, application and filing procedures in the Territory and we will provide clinical and regulatory personnel services to assist in coordination of the execution of the clinical study in China and also with CMC personnel services for drug supply and manufacturing planning. Hepalink is obligated to make an additional equity investment of \$10.8 million into SABC in connection with a future financing of SABC provided that (i) such financing does not occur earlier than January 1, 2019, (ii) top-line clinical results of the first global AR-301 Phase 3 study are available, (iii) CFDA approval for a Phase 3 clinical trial in China is granted, (iv) we have not breached the Amended and Restated Technology License and Collaboration Agreement and (v) the SABC Board has approved such financing. If and to the extent these milestone events occur and Hepalink contributes additional capital to SABC, our 49% ownership stake in SABC will be diminished in proportion to such investment.

While SABC is obligated to use its commercially best efforts to commercialize our products and product candidates in the Territory, we have limited contractual rights to direct its activities. Hepalink has the majority of the voting equity in SABC and has the right to designate three of five board seats. Therefore, Hepalink may have a greater influence in the commercialization efforts and other operations of SABC. In general, our joint venture with Hepalink subjects us to a number of related risks including that:

- SABC may not commit sufficient resources to the marketing and distribution of our products in the Territory;
- SABC may infringe the intellectual property rights of third parties, which may expose us to litigation and other potential liability;
- as long as we remain a shareholder of SABC, any cash that we contribute to SABC may not be transferred back to us or converted into USD and thus, may only be used for goods and services in China;
- disputes may arise among SABC, Hepalink and us that result in the delay or termination of the commercialization of our products or product candidates or that result in costly litigation or arbitration that diverts management attention and resources; and
- SABC may not provide us with timely and accurate information regarding commercialization status or results, which could adversely impact our ability to manage our own commercialization efforts, accurately forecast financial results or provide timely information to our shareholders regarding our commercialization efforts in the Territory.

While we believe that our board representation, voting rights and other contractual rights with respect to SABC serve to mitigate some of these risks, we may have disagreements with the other directors and Hepalink that could impair our ability to influence SABC to act in a manner that we believe is in the best interests of our company. Upon the completion of certain milestone events, Hepalink will become obligated to acquire additional shares of SABC, the proceeds of which would be received by SABC in exchange for newly issued shares. We may not be able to access the funds for our own operations.

The laws of the People's Republic of China, which govern SABC's management and operations, may not offer the same protections afforded to minority stockholders under the Delaware General Corporation Law. Consequently, SABC may make business decisions that are not in our best interests as minority equity holders.

### **Risks Relating to Competitive Factors**

***We compete in an industry characterized by extensive research and development efforts and rapid technological progress. New discoveries or commercial developments by our competitors could render our potential products obsolete or non-competitive.***

New developments occur and are expected to continue to occur at a rapid pace in our industry, and there can be no assurance that discoveries or commercial developments by our competitors will not render some or all of our potential products obsolete or non-competitive, which could have a material adverse effect on our business, financial condition and results of operations. New data from commercial and clinical-stage products continue to emerge and it is possible that these data may alter current standards of care, completely precluding us from further developing our product candidates or preventing us from getting them approved by regulatory agencies. Further, it is possible that we may initiate a clinical trial or trials for our product candidates, only to find that data from competing products make it impossible for us to complete enrollment in these trials, resulting in our inability to file for marketing approval with regulatory agencies. Even if these products are approved for marketing in a particular indication or indications, they may have limited sales due to particularly intense competition in these markets.

We expect to compete with fully integrated and well-established pharmaceutical and biotechnology companies in the near- and long-term. Most of these companies have substantially greater financial, research and development, manufacturing and marketing experience and resources than we do and represent substantial long-term competition for us. Such companies may succeed in discovering and developing pharmaceutical products more rapidly than we do or pharmaceutical products that are safer, more effective or less costly than any that we may develop. Such companies also may be more successful than we are in manufacturing, sales and marketing. Smaller companies may also prove to be significant competitors, particularly through collaborative arrangements with large pharmaceutical and established biotechnology companies. Academic institutions, governmental agencies and other public and private research organizations also conduct clinical trials, seek patent protection and establish collaborative arrangements for the development of product candidates.

We expect competition among products will be based on product efficacy and safety, the timing and scope of regulatory approvals, availability of supply, marketing and sales capabilities, reimbursement coverage, price and patent position. There can be no assurance that our competitors will not develop safer and more effective products, commercialize products earlier than we do, or obtain patent protection or intellectual property rights that limit our ability to commercialize our products.

There can be no assurance that our issued patents or pending patent applications, if issued, will not be challenged, invalidated or circumvented or that the rights granted thereunder will provide us with proprietary protection or a competitive advantage.

***Our competitors may develop and market products that are less expensive, more effective, safer or reach the market sooner than our product candidates, which may diminish or eliminate the commercial success of any products we may commercialize.***

The biopharmaceutical industry is highly competitive. There are many public and private biopharmaceutical companies, public and private universities and research organizations actively engaged in the discovery and research and development of products for infectious disease. Several companies are developing mAbs to treat infections, including Merck & Co., AstraZeneca, VIR Biotechnology, Regeneron, Eli Lilly, Adimab, Alopexx Enterprises, LLC, etc.

There is no assurance, however, that another company will not discover how to successfully develop these antibodies for competing indications.

Among current antimicrobial therapies, antibiotics, particularly those administered by inhalation, can be competitors to our products especially AR-501 for lung infections. Examples include TOBI (inhaled tobramycin) and Cayston (inhaled aztreonam). Additionally, the introduction of Vertex's channel corrector therapies could alter cystic fibrosis patients' dependencies on chronic antimicrobial therapies. There are antibiotics being developed for gram-positive or gram-negative bacterial infections that could impact the use of standard of care antibiotics in hospitals. These therapies could impact both the clinical results and use of our products being developed for hospital acquired pneumonia.

Many of our competitors, either alone or with their strategic collaborators, have substantially greater financial, technical and human resources than we do and significantly greater experience in the discovery and development of drugs, obtaining FDA and other regulatory approvals, and the commercialization of those products. Accordingly, our competitors may be more successful in obtaining approval for drugs and achieving widespread market acceptance. Our competitors' drugs may be more effective, or more effectively marketed and sold, than any drug we may commercialize and may render our product candidates obsolete or non-competitive before we can recover the significant expenses of developing and commercializing any of our product candidates. We anticipate that we will face intense and increasing competition as new drugs enter the market and advanced technologies become available.

We also compete with other clinical-stage companies and institutions for clinical trial participants, which could reduce our ability to recruit participants for our clinical trials. Delay in recruiting clinical trial participants could adversely affect our ability to bring a product to market prior to our competitors. Further, research and discoveries by others may result in breakthroughs that render our product candidates obsolete even before they begin to generate any revenue.

In addition, our competitors may obtain patent protection or FDA approval and commercialize products more rapidly than we do, which may impact future sales of any of our product candidates that receive marketing approval. If the FDA approves the commercial sale of any of our product candidates, we will also be competing with respect to marketing capabilities and manufacturing efficiency, areas in which we have limited or no experience. We expect competition among products will be based on product efficacy and safety, the timing and scope of regulatory approvals, availability of supply, marketing and sales capabilities, product price, reimbursement coverage by government and private third-party payors, and patent position. Our profitability and financial position will suffer if our products receive regulatory approval but cannot compete effectively in the marketplace.

If any of our product candidates are approved and commercialized, we may face competition from biosimilars. The route to market for biosimilars was established with the passage of the Patient Protection and Affordable Care Act, or PPACA, in March 2010, providing 12 years of marketing exclusivity for reference products and an additional six months of exclusivity if pediatric studies are conducted. In the EU, the EMA has issued guidelines for approving products through an abbreviated pathway, and biosimilars have been approved. If a biosimilar version of one of our potential products were approved in the U.S. or EU, it could have a negative effect on sales and gross profits of the potential product and our financial condition.

***Even if we achieve market acceptance for our products, we may experience downward pricing pressure on the price of our drugs because of generic and biosimilar competition and social pressure to lower the cost of drugs.***

Several of the FDA approved products for infectious diseases face patent expiration in the next several years. As a result, generic versions and biosimilars of these drugs and biologicals may become available. We expect to face competition from these products, including price-based competition. Pressure from government and private reimbursement groups, plus patient awareness and other social activist groups to reduce drug prices may also put downward pressure on the prices of drugs, including our product candidates, if they are commercialized. Also, if a biosimilar to any of our product candidates is approved by regulatory agencies, there will be significant pricing pressure on our products, causing us or our collaborators to reduce the sales price of our products.

***Our product candidates may not be accepted in the marketplace; therefore, we may not be able to generate significant revenue, if any.***

Even if our product candidates are approved for sale, physicians and the medical community may not ultimately use them or may use them only in applications more restricted than we expect. Our product candidates, if successfully developed, will compete with a number of traditional products, including antibiotics, and immunotherapies manufactured and marketed by major pharmaceutical and other biotechnology companies. Our product candidates will also compete with new products currently under development by such companies and others. Physicians will prescribe a product only if they determine, based on experience, clinical data, side effect profiles, reimbursement for their patients and other factors, that it is beneficial as compared to other products currently in use. Furthermore, physicians have been prescribing traditional antibiotics for decades and may be resistant to switching to new, less established therapies. Many other factors influence the adoption of new products, including marketing and distribution restrictions, course of treatment, adverse publicity, product pricing, the views of thought leaders in the medical community and reimbursement by government and private third-party payors.

## **Risks Relating to our Reliance on Third Parties**

***We rely on third parties to conduct our preclinical studies and our clinical trials and to store and distribute our products for the clinical trials we conduct. If these third parties do not perform as contractually required or expected, we may not be able to obtain regulatory approval for our product candidates, or we may be delayed in doing so.***

We often rely on third parties, such as CROs, medical institutions, academic institutions, clinical investigators and contract laboratories, to conduct our preclinical studies and clinical trials. We are responsible for confirming that our preclinical studies are conducted in accordance with applicable regulations and that each of our clinical trials is conducted in accordance with its general investigational plan and protocol. The FDA requires us to comply with Good Laboratory Practice for conducting and recording the results of our preclinical studies and Good Clinical Practices, or GCP, for conducting, monitoring, recording and reporting the results of clinical trials, to ensure that data and reported results are accurate and that the clinical trial participants are adequately protected. Our reliance on third parties does not relieve us of these responsibilities. If the third parties conducting our clinical trials do not perform their contractual duties or obligations, do not meet expected deadlines, fail to comply with GCP, do not adhere to our clinical trial protocols or otherwise fail to generate reliable clinical data, we may need to enter into new arrangements with alternative third parties and our clinical trials may be more costly than expected or budgeted, extended, delayed or terminated or may need to be repeated, and we may not be able to obtain regulatory approval for or commercialize the product candidate being tested in such trials.

Our CROs are not our employees, and we are therefore unable to directly monitor whether or not they devote sufficient time and resources to our clinical and preclinical programs. These CROs may also have relationships with other commercial entities, including our competitors, for whom they may also be conducting clinical trials or other product development activities that could harm our competitive position. If our CROs do not successfully carry out their contractual duties or obligations, fail to meet expected deadlines, or if the quality or accuracy of the clinical data they obtain is compromised due to the failure to adhere to our clinical protocols or regulatory requirements, or for any other reasons, our clinical trials may be extended, delayed or terminated, and we may not be able to obtain regulatory approval for, or successfully commercialize, our therapeutic candidates. If any such event were to occur, our financial results and the commercial prospects for our therapeutic candidates would be harmed, our costs could increase, and our ability to generate revenues could be delayed.

If any of our relationships with these third-party CROs terminate, we may not be able to enter into arrangements with alternative CROs or to do so on commercially reasonable terms. Further, switching or adding additional CROs involves additional costs and requires management time and focus. In addition, there is a natural transition period when a new CRO commences work. As a result, delays occur, which could materially impact our ability to meet our desired clinical development timelines. Though we carefully manage our relationships with our CROs, there can be no assurance that we will not encounter challenges or delays in the future or that these delays or challenges will not have a material adverse impact on our business, financial condition and prospects.

In addition, our future clinical trials will require a sufficient number of test subjects to evaluate the safety and effectiveness of our therapeutic candidates. Accordingly, if our CROs fail to comply with these regulations or fail to recruit a sufficient number of patients, we may be required to repeat such clinical trials, which would delay the regulatory approval process.

We also rely on other third parties to store and distribute our products for the clinical trials that we conduct. Any performance failure on the part of our distributors could delay clinical development or marketing approval of our therapeutic candidates or commercialization of our products, if approved, producing additional losses and depriving us of potential product revenue.

***We may explore new strategic collaborations that may never materialize or may fail.***

We may, in the future, periodically explore a variety of new strategic collaborations in an effort to gain access to additional product candidates or resources. At the current time, we cannot predict what form such a strategic collaboration might take. We are likely to face significant competition in seeking appropriate strategic collaborators, and these strategic collaborations can be complicated and time-consuming to negotiate and document. We may not be able to negotiate strategic collaborations on acceptable terms, or at all. We are unable to predict when, if ever, we will enter into any additional strategic collaborations because of the numerous risks and uncertainties associated with establishing strategic collaborations.

## **Risks Relating to our Exposure to Litigation**

***We are exposed to potential product liability or similar claims, and insurance against these claims may not be available to us at a reasonable rate in the future.***

Our business exposes us to potential liability risks that are inherent in the testing, manufacturing and marketing of human therapeutic products. Clinical trials involve the testing of product candidates on human subjects or volunteers under a research plan and carry a risk of liability for personal injury or death to patients due to unforeseen adverse side effects, improper administration of the product candidate, or other factors. Many of these patients are already seriously ill and are therefore particularly vulnerable to further illness or death.

We believe we have adequate levels of clinical trial liability insurance for our domestic and international clinical trials. However, there can be no assurance that we will be able to maintain such insurance or that the amount of such insurance will be adequate to cover claims. We could be materially and adversely affected if we were required to pay damages or incur defense costs in connection with a claim outside the scope of indemnity or insurance coverage, if the indemnity is not performed or enforced in accordance with its terms, or if our liability exceeds the amount of applicable insurance. In addition, there can be no assurance that insurance will continue to be available on terms acceptable to us, if at all, or that if obtained, the insurance coverage will be sufficient to cover any potential claims or liabilities. Similar risks would exist upon the commercialization or marketing of any products by us or our collaborators.

Regardless of their merit or eventual outcome, product liability claims may result in:

- decreased demand for our product;
- injury to our reputation and significant negative media attention;
- withdrawal of clinical trial volunteers;
- costs of litigation;
- distraction of management; and
- substantial monetary awards to plaintiffs.

Should any of these events occur, it could have a material adverse effect on our business and financial condition.

***Claims for indemnification by our directors and officers may reduce our available funds to satisfy successful third-party claims against us and may reduce the amount of money available to the Company.***

Our certificate of incorporation provides that we will indemnify our directors to the fullest extent permitted by Delaware law.

In addition, as permitted by Section 145 of the Delaware General Corporation Law, our bylaws provide that:

- we may, in our discretion, indemnify other officers, employees and agents in those circumstances where indemnification is permitted by applicable law;
- we are required to advance expenses, as incurred, to our directors and executive officers in connection with defending a proceeding, except that such directors or executive officers shall undertake to repay such advances if it is ultimately determined that such person is not entitled to indemnification;

- we will not be obligated pursuant to our bylaws to indemnify any director or executive officer in connection with any proceeding (or part thereof) initiated by such person unless (i) such indemnification is expressly required to be made by law, (ii) the proceeding was authorized by our Board of Directors, (iii) such indemnification is provided by us, in our sole discretion, pursuant to the powers vested in the corporation under applicable law or (iv) such indemnification is required to be made pursuant to our amended and restated bylaws;
- the rights conferred in our bylaws are not exclusive, and we are authorized to enter into indemnification agreements with our directors, officers, employees and agents and to obtain insurance to indemnify such persons; and
- we may not retroactively amend our bylaw provisions to reduce our indemnification obligations to directors, officers, employees and agents.

As a result, if we are required to indemnify one or more of our directors or executive officers, it may reduce our available funds to satisfy successful third-party claims against us, may reduce the amount of money available to us and may have a material adverse effect on our business and financial condition.

### **Risks Relating to Regulation of Our Industry**

***The biopharmaceutical industry is subject to significant regulation and oversight in the United States, in addition to approval of products for sale and marketing. We may be subject, directly or indirectly, to federal and state healthcare fraud and abuse laws, transparency, health information privacy and security laws and other healthcare laws and regulations. If we are unable to comply, or have not fully complied, with such laws, we could face substantial penalties.***

Healthcare providers, physicians and third-party payors will play a primary role in the recommendation and prescription of any future product candidates we may develop and any product candidates for which we obtain marketing approval. In addition to FDA restrictions on marketing of biopharmaceutical products, we are exposed, directly, or indirectly, through our customers, to broadly applicable fraud and abuse and other healthcare laws and regulations that may affect the business or financial arrangements and relationships through which we would market, sell and distribute our products. The laws that may affect our ability to operate include, but are not limited to:

The federal Anti-Kickback Statute which prohibits any person or entity from, among other things, knowingly and willfully offering, paying, soliciting or receiving any remuneration, directly or indirectly, overtly or covertly, in cash or in-kind, to induce or reward either the referring of an individual for, or the purchasing, leasing, ordering or arranging for the purchase, lease or order of any health care item or service reimbursable, in whole or in part, under Medicare, Medicaid or any other federally financed healthcare program. The term “remuneration” has been broadly interpreted to include anything of value. This statute has been interpreted to apply to arrangements between pharmaceutical manufacturers on one hand and prescribers, purchasers and formulary managers on the other hand. Although there are a number of statutory exceptions and regulatory safe harbors protecting certain common activities from prosecution, the exceptions and safe harbors are drawn narrowly, and practices that involve remuneration intended to induce prescribing, purchases or recommendations may be subject to scrutiny if they do not qualify for an exception or safe harbor. Our practices may not in all cases meet all of the criteria for safe harbor protection from federal Anti-Kickback Statute liability.

The federal false claims and civil monetary penalty laws, including the Federal False Claims Act, which imposes significant penalties and can be enforced by private citizens through civil qui tam actions, prohibits any person or entity from, among other things, knowingly presenting, or causing to be presented, a false, fictitious or fraudulent claim for payment to the federal government, or knowingly making, using or causing to be made, a false statement or record material to a false or fraudulent claim to avoid, decrease or conceal an obligation to pay money to the federal government. In addition, a claim including items or services resulting from a violation of the federal Anti-Kickback Statute constitutes a false or fraudulent claim for purposes of the Federal False Claims Act. As a result of a modification made by the Fraud Enforcement and Recovery Act of 2009, a claim includes “any request or demand” for money or property presented to the U.S. government. Further, manufacturers can be held liable under the False Claims Act even when they do not submit claims directly to government payors if they are deemed to “cause” the submission of false or fraudulent claims. Criminal prosecution is also possible for making or presenting a false, fictitious or fraudulent claim to the federal government. Several pharmaceutical and other health care companies have been prosecuted under these laws for allegedly providing free product to customers



with the expectation that the customers would bill federal programs for the product. Other companies have been prosecuted for causing false claims to be submitted because of marketing of the product for unapproved, and thus non-reimbursable, uses.

The federal Health Insurance Portability and Accountability Act of 1996, or HIPAA, which, among other things, imposes criminal liability for executing or attempting to execute a scheme to defraud any healthcare benefit program, including private third-party payors, knowingly and willfully embezzling or stealing from a healthcare benefit program, willfully obstructing a criminal investigation of a healthcare offense, and creates federal criminal laws that prohibit knowingly and willfully falsifying, concealing or covering up a material fact or making any materially false, fictitious or fraudulent statements or representations, or making or using any false writing or document knowing the same to contain any materially false, fictitious or fraudulent statement or entry in connection with the delivery of or payment for healthcare benefits, items or services.

HIPAA, as amended by the Health Information Technology for Economic and Clinical Health Act of 2009, or HITECH, and its implementing regulations, which impose certain requirements relating to the privacy, security, transmission and breach reporting of individually identifiable health information upon entities subject to the law, such as health plans, healthcare clearinghouses and certain healthcare providers and their respective business associates that perform services for them that involve individually identifiable health information. HITECH also created new tiers of civil monetary penalties, amended HIPAA to make civil and criminal penalties directly applicable to business associates, and gave state attorneys general new authority to file civil actions for damages or injunctions in U.S. federal courts to enforce the federal HIPAA laws and seek attorneys' fees and costs associated with pursuing federal civil actions.

The federal physician payment transparency requirements, sometimes referred to as the "Physician Payments Sunshine Act," and its implementing regulations, which require certain manufacturers of drugs, devices, biologics and medical supplies for which payment is available under Medicare, Medicaid or the Children's Health Insurance Program (with certain exceptions) to report annually to the United States Department of Health and Human Services, or HHS, information related to payments or other transfers of value made to physicians (defined to include doctors, dentists, optometrists, podiatrists and chiropractors) and teaching hospitals, as well as ownership and investment interests held by physicians and their immediate family members.

State and foreign law equivalents of each of the above federal laws, such as anti-kickback and false claims laws, that may impose similar or more prohibitive restrictions, and may apply to items or services reimbursed by non-governmental third-party payors, including private insurers.

State laws that require pharmaceutical companies to implement compliance programs, comply with the pharmaceutical industry's voluntary compliance guidelines and the relevant compliance guidance promulgated by the federal government, or to track and report gifts, compensation and other remuneration provided to physicians and other healthcare providers, state and local laws that require the registration of pharmaceutical sales representatives, and other federal, state and foreign laws that govern the privacy and security of health information or personally identifiable information in certain circumstances, including state health information privacy and data breach notification laws which govern the collection, use, disclosure, and protection of health-related and other personal information, many of which differ from each other in significant ways and often are not pre-empted by HIPAA, thus requiring additional compliance efforts.

Because of the breadth of these laws and the narrowness of the safe harbors, it is possible that some of our business activities could be subject to challenge under one or more of these laws. The scope and enforcement of each of these laws is uncertain and subject to rapid change in the current environment of healthcare reform, especially in light of the lack of applicable precedent and regulations. Federal and state enforcement bodies have recently increased their scrutiny of interactions between healthcare companies and healthcare providers, which has led to a number of investigations, prosecutions, convictions and settlements in the healthcare industry.

Ensuring that our business arrangements with third parties comply with applicable healthcare laws and regulations will likely be costly and time consuming. If our operations are found to be in violation of any of the laws described above or any other governmental regulations that apply to us, we may be subject to penalties, including civil, criminal and administrative penalties, damages, fines, disgorgement, individual imprisonment, exclusion from governmental funded healthcare programs, such as Medicare and Medicaid, contractual damages, reputational harm, diminished profits and future earnings, additional reporting obligations and oversight if we become subject to a corporate integrity agreement or other agreement to resolve allegations of non-compliance with these laws, and the curtailment or restructuring of our operations, any of which could adversely affect our ability to operate our business and our results of operations.

***Our employees may engage in misconduct or other improper activities, including noncompliance with regulatory standards and requirements, which could have a material adverse effect on our business.***

We are exposed to the risk of employee fraud or other misconduct. Misconduct by employees could include intentional failures to comply with FDA regulations, provide accurate information to the FDA, comply with manufacturing standards we have established, comply with federal and state health-care fraud and abuse laws and regulations, report financial information or data accurately or disclose unauthorized activities to us. In particular, sales, marketing and business arrangements in the healthcare industry are subject to extensive laws and regulations intended to prevent fraud, kickbacks, self-dealing and other abusive practices. These laws and regulations may restrict or prohibit a wide range of pricing, discounting, marketing and promotion, sales commission, customer incentive programs and other business arrangements. Employee misconduct could also involve the improper use of information obtained in the course of clinical trials, which could result in regulatory sanctions and serious harm to our reputation. It is not always possible to identify and deter employee misconduct, and the precautions we take to detect and prevent misconduct may not be effective in controlling unknown or unmanaged risks or losses or in protecting us from governmental investigations or other actions or lawsuits stemming from a failure to be in compliance with such laws or regulations. If any such actions are instituted against us, and we are not successful in defending ourselves or asserting our rights, those actions could have a significant impact on our business and results of operations, including the imposition of significant civil, criminal, and administrative penalties, damages, fines, disgorgement, individual imprisonment, exclusion from governmental funded healthcare programs, such as Medicare and Medicaid, contractual damages, reputational harm, diminished profits and future earnings, additional reporting obligations and oversight if subject to a corporate integrity agreement or other agreement to resolve allegations of non-compliance with these laws.

***Health care reform measures could adversely affect our business.***

In the United States and foreign jurisdictions, there have been, and continue to be, a number of legislative and regulatory changes and proposed changes to the healthcare system that could affect our future results of operations. In particular, there have been and continue to be a number of initiatives at the U.S. federal and state levels that seek to reduce healthcare costs. In 2010, the PPACA was enacted, which includes measures to significantly change the way health care is financed by both governmental and private insurers. Among the provisions of the PPACA of greatest importance to the pharmaceutical and biotechnology industry are the following:

- an annual, nondeductible fee on any entity that manufactures or imports certain branded prescription drugs and biologic agents, apportioned among these entities according to their market share in certain government healthcare programs;
- implementation of the federal physician payment transparency requirements, sometimes referred to as the “Physician Payments Sunshine Act”;
- a licensure framework for follow-on biologic products;
- a new Patient-Centered Outcomes Research Institute to oversee, identify priorities in, and conduct comparative clinical effectiveness research, along with funding for such research;
- establishment of a Center for Medicare Innovation at the Centers for Medicare & Medicaid Services, or CMS, to test innovative payment and service delivery models to lower Medicare and Medicaid spending, potentially including prescription drug spending;
- an increase in the statutory minimum rebates a manufacturer must pay under the Medicaid Drug Rebate Program, to 23.1% and 13% of the average manufacturer price for most branded and generic drugs, respectively and capped the total rebate amount for innovator drugs at 100% of the Average Manufacturer Price, or AMP;
- a new methodology by which rebates owed by manufacturers under the Medicaid Drug Rebate Program are calculated for certain drugs and biologics, including our product candidates, that are inhaled, infused, instilled, implanted or injected;
- extension of manufacturers’ Medicaid rebate liability to covered drugs dispensed to individuals who are enrolled in Medicaid managed care organizations;

- expansion of eligibility criteria for Medicaid programs by, among other things, allowing states to offer Medicaid coverage to additional individuals and by adding new mandatory eligibility categories for individuals with income at or below 133% of the federal poverty level, thereby potentially increasing manufacturers' Medicaid rebate liability;
- a new Medicare Part D coverage gap discount program, in which manufacturers must agree to offer 70% point-of-sale discounts off negotiated prices of applicable brand drugs to eligible beneficiaries during their coverage gap period, as a condition for the manufacturers' outpatient drugs to be covered under Medicare Part D; and
- expansion of the entities eligible for discounts under the Public Health program.

Some of the provisions of the PPACA have yet to be implemented, and there have been legal and political challenges to certain aspects of the PPACA. During President Trump's administration, he signed two executive orders and other directives designed to delay, circumvent, or loosen certain requirements mandated by the PPACA. Concurrently, Congress has considered legislation that would repeal or repeal and replace all or part of the PPACA. While Congress has not passed repeal legislation, the Tax Cuts and Jobs Act of 2017 ("TCJA") includes a provision repealing, effective January 1, 2019, the tax-based shared responsibility payment imposed by the PPACA on certain individuals who fail to maintain qualifying health coverage for all or part of a year that is commonly referred to as the "individual mandate". Congress may consider other legislation to repeal or replace elements of the PPACA.

Many of the details regarding the implementation of the PPACA are yet to be determined, and at this time, the full effect that the PPACA would have on our business remains unclear. In particular, there is uncertainty surrounding the applicability of the biosimilars provisions under the PPACA to our product candidates. The FDA has issued several guidance documents, and withdrawn others, but no implementing regulations on biosimilars have been adopted. A number of biosimilar applications have been approved over the past few years. It is not certain that we will receive 12 years of biologics marketing exclusivity for any of our products. The regulations that are ultimately promulgated and their implementation are likely to have considerable impact on the way we conduct our business and may require us to change current strategies. A biosimilar is a biological product that is highly similar to an approved drug notwithstanding minor differences in clinically inactive components, and for which there are no clinically meaningful differences between the biological product and the approved drug in terms of the safety, purity, and potency of the product.

Individual states have become increasingly aggressive in passing legislation and implementing regulations designed to control pharmaceutical and biological product pricing, including price or patient reimbursement constraints, discounts, restrictions on certain product access, and marketing cost disclosure and transparency measures, and to encourage importation from other countries and bulk purchasing. Legally mandated price controls on payment amounts by third-party payors or other restrictions could harm a pharmaceutical manufacturer's business, results of operations, financial condition and prospects. In addition, regional healthcare authorities and individual hospitals are increasingly using bidding procedures to determine what pharmaceutical products and which suppliers will be included in their prescription drug and other healthcare programs. This could reduce ultimate demand for certain products or put pressure on product pricing, which could negatively affect a pharmaceutical manufacturer's business, results of operations, financial condition and prospects.

In addition, given recent federal and state government initiatives directed at lowering the total cost of healthcare, Congress and state legislatures will likely continue to focus on healthcare reform, the cost of prescription drugs and biologics and the reform of the Medicare and Medicaid programs. While we cannot predict the full outcome of any such legislation, it may result in decreased reimbursement for drugs and biologics, which may further exacerbate industry-wide pressure to reduce prescription drug prices. This could harm our ability to generate revenues. Increases in importation or re-importation of pharmaceutical products from foreign countries into the United States could put competitive pressure on our ability to profitably price our products, which, in turn, could adversely affect our business, results of operations, financial condition and prospects. We might elect not to seek approval for or market our products in foreign jurisdictions in order to minimize the risk of re-importation, which could also reduce the revenue we generate from our product sales. It is also possible that other legislative proposals having similar effects will be adopted.

Furthermore, regulatory authorities' assessment of the data and results required to demonstrate safety and efficacy can change over time and can be affected by many factors, such as the emergence of new information, including on other products, changing policies and agency funding, staffing and leadership. We cannot be sure whether future changes to the regulatory environment will be favorable or unfavorable to our business prospects. For example, average review times at the FDA for marketing approval applications can be affected by a variety of factors, including budget and funding levels and statutory, regulatory and policy changes.

## Risks Relating to Protecting our Intellectual Property

*If we are unable to protect our proprietary rights or to defend against infringement claims, we may not be able to compete effectively or operate profitably.*

Our success will depend, in part, on our ability to obtain patents, operate without infringing the proprietary rights of others and maintain trade secrets or other proprietary know-how, both in the United States and other countries. Patent matters in the biotechnology and pharmaceutical industries can be highly uncertain, can involve changes in laws or regulations, and involve complex legal and factual questions. Accordingly, the issuance, validity, breadth and enforceability of our patents and the existence of potentially blocking patent rights of others cannot be predicted with any degree of certainty, either in the United States or in other countries.

Obtaining, maintaining, and enforcing patents is expensive and time-consuming, and we may not be able to file and prosecute all necessary or desirable patent applications, or maintain, enforce and/or license patents that may issue based on our patent applications, at a reasonable cost or in a timely manner. It is also possible that we will fail to identify patentable aspects of our research and development results before it is too late to obtain patent protection. Moreover, in some circumstances, we may not have the right to control the preparation, filing and prosecution of patent applications, or to maintain the patents, covering technology that we license from or license to third parties and are reliant on our licensors or licensees. Further, although we enter into non-disclosure and confidentiality agreements with parties who have access to patentable aspects of our research and development output, such as our employees, corporate collaborators, outside scientific collaborators, contract research organizations, contract manufacturers, consultants, advisors and other third parties, any of these parties may breach these agreements and disclose such results before a patent application is filed, thereby jeopardizing our ability to seek patent protection.

There can be no assurance that we will discover or develop patentable products or processes or that patents will issue from any of the currently pending patent applications or that claims granted on issued patents will be sufficient to protect our technologies, processes, or adequately cover the actual products we may actually sell. Potential competitors or other researchers in the field may have filed patent applications, been issued patents, published articles or otherwise created prior art that could restrict or block our efforts to obtain additional patents or act as obstacles to our pending patent applications. There also can be no assurance that our issued patents or pending patent applications, if issued, will not be challenged, invalidated, rendered unenforceable or not infringed, or that the rights granted thereunder will provide us with proprietary protection or competitive advantages. We may not be aware of all third-party intellectual property rights potentially relating to our product candidates or their intended uses, and as a result the impact of such third-party intellectual property rights upon the patentability of our own patents and patent applications, as well as the impact of such third-party intellectual property upon our freedom to operate, is highly uncertain. Patent applications in the U.S. and other jurisdictions are typically not published until 18 months after filing or, in some cases, not at all. Therefore, we cannot know with certainty whether we were the first to make the inventions claimed in our patents or pending patent applications, or that we were the first to file for patent protection of such inventions. As a result, the issuance, scope, validity, enforceability and commercial value of our patent rights are highly uncertain. Our patents or pending patent applications may be challenged in the courts or patent offices in the U.S. and abroad. For example, we may be subject to a third-party pre-issuance submission of prior art to the U.S. Patent and Trademark Office, or become involved in post-grant review procedures, oppositions, derivations, reexaminations, inter partes review or interference proceedings, in the U.S. or elsewhere, challenging our patent rights or the patent rights of others. An adverse determination in any such challenges may result in loss of exclusivity or in patent claims being narrowed, invalidated, or held unenforceable, in whole or in part, which could limit our ability to stop others from using or commercializing similar or identical technology and products, or limit the duration of the patent protection of our technology and products. In addition, given the amount of time required for the development, testing and regulatory review of new product candidates, patents protecting such candidates might expire before or shortly after such candidates are commercialized. The patent position of biopharmaceutical companies generally is highly uncertain, involves complex legal and factual questions and has in recent years been the subject of much litigation, resulting in court decisions, including Supreme Court decisions, that have increased uncertainties as to the ability to enforce patent rights in the future. In addition, the laws of foreign countries may not protect our rights to the same extent as the laws of the U.S., or vice versa. Our patent rights also depend on our compliance with technology and patent licenses upon which our patent rights are based and upon the validity of assignments of patent rights from consultants and other inventors that were, or are, not employed by us.

In addition, competitors may manufacture and sell our potential products in those foreign countries where we have not filed for patent protection or where patent protection may be unavailable, not obtainable or ultimately not enforceable or meaningful. In addition, even where patent protection is obtained, third-party competitors may challenge our patent claims in the various patent offices, for example via opposition in the European Patent Office or reexamination or interference proceedings in the United States Patent and

Trademark Office, or USPTO, or find ways to design around our patents by producing competitive non-infringing alternative products. The ability of such competitors to sell such products in the United States or in foreign countries where we have obtained patents is usually governed by the patent laws of the countries in which the product is sold.

We will incur significant ongoing expenses in maintaining our patent portfolio in addition to maintaining other registered intellectual property such as trademarks and copyrights. Maintaining registered intellectual property such as patents and trademarks requires timely filing certain maintenance documents and paying certain maintenance fees, the failure of which could result in abandonment or cancellation of such registered intellectual property. Should we lack the funds to maintain our patent portfolio or other registered intellectual property, or to enforce our rights against infringers, we could be adversely impacted. Even if we succeed in enforcing one of our patents against a third-party in a claim of infringement, any such action could divert the time and attention of management and impair our ability to access additional capital and/or cost us significant funds.

***If we cannot meet requirements under our license and sublicense agreements, we could lose the rights to our products, which could have a material adverse effect on our business.***

We depend on licensing and sublicensing agreements with third parties such as the University of Chicago, University of Iowa, Brigham and Women's Hospital, Inc., Brigham Young University, Public Health Service, Kenta Biotech Ltd., Massachusetts Institute of Technology-Broad Institute, University of Alabama at Birmingham Research Foundation, and Medimmune Ltd. to maintain the intellectual property rights to certain of our product candidates. These agreements require us to make payments and satisfy performance obligations in order to maintain our rights under these agreements. All of these agreements last either throughout the life of the patents that are the subject of the agreements, or with respect to other licensed technology, for a number of years after the first commercial sale of the relevant product. If we fail to comply with the obligations under our license agreements or use the intellectual property licensed to us in an unauthorized manner, we may be required to pay damages and our licensors may have the right to terminate the license. If our license agreements are terminated, we may not be able to develop, manufacture, market or sell the products covered by our agreements and those being tested or approved in combination with such products. Such an occurrence could materially adversely affect the value of the product candidate being developed under any such agreement and any other product candidates being developed or tested in combination.

In addition, we are responsible for the cost of filing and prosecuting certain patent applications and maintaining certain issued patents licensed to us. If we do not meet our obligations under our license agreements in a timely manner, or use the intellectual property licensed to us in an unauthorized manner, we could be required to pay damages and we could lose the rights to our proprietary technology if our licensor terminated the license. If our license agreements are terminated, we may not be able to develop, manufacture, market or sell the products covered by our agreements and any being tested or approved in combination with such products. Such an occurrence could have a material adverse effect on our business, results of operations and financial condition.

***Intellectual property rights do not necessarily address all potential threats to our competitive advantage.***

The degree of future protection afforded by our intellectual property rights is uncertain because intellectual property rights have limitations, and may not adequately protect our business, or permit us to maintain our competitive advantage. The following examples are illustrative:

- others may be able to make compounds that are similar to our product candidates but that are not covered by the claims of the patents that we own or have exclusively licensed;
- we or our licensors or strategic collaborators might not have been the first to make the inventions covered by the issued patent or pending patent application that we own or have exclusively licensed;
- we or our licensors or strategic collaborators might not have been the first to file patent applications covering certain of our inventions;
- others may independently develop similar or alternative technologies or duplicate any of our technologies without infringing our intellectual property rights;
- it is possible that our pending patent applications will not lead to issued patents;

- issued patents that we own or have exclusively licensed may not provide us with any competitive advantages, or may be held invalid or unenforceable, as a result of legal challenges by our competitors;
- our competitors might conduct research and development activities in countries where we do not have patent rights and then use the information learned from such activities to develop competitive products for sale in our major commercial markets;
- we may not develop additional proprietary technologies that are patentable; and
- the patents of others may have an adverse effect on our business.

Should any of these events occur, they could significantly harm our business, results of operations and prospects.

***Patent reform legislation could increase the uncertainties and costs surrounding the prosecution of our patent applications and the enforcement or defense of our issued patents.***

Changes in either the patent laws or interpretation of the patent laws in the United States and Ex-US could increase the uncertainties and costs. Recent patent reform legislation in the United States and other countries, including the Leahy-Smith America Invents Act, or the Leahy-Smith Act, signed into law in the United States on September 16, 2011, could increase those uncertainties and costs surrounding the prosecution of our patent applications and the enforcement or defense of our issued patents. The Leahy-Smith Act includes a number of significant changes to U.S. patent law. These include provisions that affect the way patent applications are prosecuted, redefine prior art and provide more efficient and cost-effective avenues for competitors to challenge the validity of patents. These include allowing third-party submission of prior art to the USPTO during patent prosecution and additional procedures to attack the validity of a patent by USPTO administered post-grant proceedings, including post-grant review, inter partes review, and derivation proceedings. After March 2013, under the Leahy-Smith Act, the United States transitioned to a first inventor to file system in which, assuming that the other statutory requirements are met, the first inventor to file a patent application will be entitled to the patent on an invention regardless of whether a third-party was the first to invent the claimed invention. However, the Leahy-Smith Act and its implementation could increase the uncertainties and costs surrounding the prosecution of our patent applications and the enforcement or defense of our issued patents, all of which could have a material adverse effect on our business, financial condition, results of operations and prospects.

The U.S. Supreme Court has ruled on several patent cases in recent years, either narrowing the scope of patent protection available in certain circumstances or weakening the rights of patent owners in certain situations. Depending on future actions by the U.S. Congress, the U.S. courts, the USPTO and the relevant law-making bodies in other countries, the laws and regulations governing patents could change in unpredictable ways that would weaken our ability to obtain new patents or to enforce our existing patents and patents that we might obtain in the future.

***We may be subject to litigation with respect to the ownership and use of intellectual property that will be costly to defend or pursue and uncertain in its outcome.***

Our success also will depend, in part, on our refraining from infringing patents or otherwise violating intellectual property owned or controlled by others. There is a substantial amount of intellectual property litigation in the biotechnology and pharmaceutical industries, and we may become party to, or threatened with, litigation or other adversarial proceedings regarding intellectual property rights with respect to our products candidates, including interference proceedings before the U.S. Patent and Trademark Office. Pharmaceutical companies, biotechnology companies, universities, research institutions and others may have filed patent applications or have received, or may obtain, issued patents in the United States or elsewhere relating to aspects of our technology, and it may not always be clear to industry participants, including us, which patents cover various types of products or methods of use. The coverage of patents is subject to interpretation by the courts, and the interpretation is not always uniform. Third parties may allege that we have infringed or misappropriated their intellectual property. If we were sued for patent infringement, we would need to demonstrate that our product candidates, products or methods either do not infringe the patent claims of the relevant patent or that the patent claims are invalid or unenforceable, and we may not be able to do this. Proving invalidity is difficult. For example, in the United States, proving invalidity requires a showing of clear and convincing evidence to overcome the presumption of validity enjoyed by issued patents. Even if we are successful in these proceedings, we may incur substantial costs and the time and attention of our management and scientific personnel

could be diverted in pursuing these proceedings, which could have a material adverse effect on us. In addition, we may not have sufficient resources to bring these actions to a successful conclusion.

Litigation or other legal proceedings relating to intellectual property claims, with or without merit, is unpredictable and generally expensive and time consuming and, even if resolved in our favor, is likely to divert significant resources from our core business, including distracting our technical and management personnel from their normal responsibilities. In addition, there could be public announcements of the results of hearings, motions or other interim proceedings or developments and if securities analysts or investors perceive these results to be negative, it could have a substantial adverse effect on the market price of our common stock. Such litigation or proceedings could substantially increase our operating losses and reduce the resources available for development activities or any future sales, marketing or distribution activities. We may not have sufficient financial or other resources to adequately conduct such litigation or proceedings. Some of our competitors may be able to sustain the costs of such litigation or proceedings more effectively than we can because of their greater financial resources and more mature and developed intellectual property portfolios.

If we are found to infringe a third-party's intellectual property rights, we could be forced, including by court order, to cease developing, manufacturing or commercializing the infringing product candidate or product. Alternatively, we may be required to obtain a license from such third-party in order to use the infringing technology and continue developing, manufacturing or marketing the infringing product candidate. However, we may not be able to obtain any required license on commercially reasonable terms or at all. Even if we were able to obtain a license, it could be non-exclusive, thereby giving our competitors access to the same technologies licensed to us. In addition, we could be found liable for monetary damages, including treble damages and attorneys' fees if we are found to have willfully infringed a patent. A finding of infringement could prevent us from commercializing our product candidates or force us to cease some of our business operations, which could materially harm our business. Claims that we have misappropriated the confidential information or trade secrets of third parties could have a similar negative impact on our business.

It is uncertain whether the issuance of any third-party patents will require us to alter our products or processes, obtain licenses, if such licenses are available on commercially reasonable terms, or cease certain activities completely. Some third-party applications or patents may conflict with our issued patents or pending applications. Any such conflict could result in a significant reduction of the scope or value of our issued or licensed patents.

In addition, if patents issued to other companies contain blocking, dominating or conflicting claims and such claims are ultimately determined to be valid, we may be required to obtain licenses to these patents or to develop or obtain alternative non-infringing technology and cease practicing those activities, including potentially manufacturing or selling any products deemed to infringe those patents. If any licenses are required, there can be no assurance that we will be able to obtain any such licenses on commercially favorable terms, if at all, and if these licenses are not obtained, we might be prevented from pursuing the development and commercialization of certain of our potential products. Our failure to obtain a license to any technology that we may require to commercialize our products on favorable terms may have a material adverse impact on our business, financial condition and results of operations.

Litigation, which could result in substantial costs to us (even if determined in our favor), may also be necessary to enforce any patents issued or licensed to us or to determine the scope and validity of the proprietary rights of others, or to defend against any accusations from third parties that our products or activities are infringing their intellectual property rights. The FDA has only recently published draft guidance documents for implementation of the Biologics Price Competition and Innovation Act, or BPCIA under the PPACA, related to the development of follow-on biologics (biosimilars), and detailed guidance for patent litigation procedures under this act has not yet been provided. If another company files for approval to market a competing follow-on biologic, and/or if such approval is given to such a company, we may be required to promptly initiate patent litigation to prevent the marketing of such biosimilar version of our product prior to the normal expiration of the patent. There can be no assurance that our issued or licensed patents would be held valid by a court of competent jurisdiction or that any follow-on biologic would be found to infringe our patents.

In addition, if our competitors file or have filed patent applications in the United States that claim technology also claimed by us, we may have to participate in interference proceedings to determine priority of invention. These proceedings, if initiated by the USPTO, could result in substantial costs to us, even if the eventual outcome is favorable to us. Such proceedings can be lengthy, are costly to defend and involve complex questions of law and fact, the outcomes of which are difficult to predict. Moreover, we may have to participate in post-grant proceedings or third-party *ex parte* or *inter partes* reexamination proceedings under the USPTO. An adverse outcome with respect to a third-party claim or in an interference proceeding could subject us to significant liabilities, require us to license disputed rights from third parties, or require us to cease using such technology, any of which could have a material adverse effect on our business, financial condition and results of operations.

***We may become involved in lawsuits to protect or enforce our patents or other intellectual property, which could be expensive, time consuming and unsuccessful.***

Competitors may infringe our patents, trademarks, copyrights or other intellectual property. To counter infringement or unauthorized use, we may be required to file infringement claims, which can be expensive and time consuming and divert the time and attention of our management and scientific personnel. Any claims we assert against perceived infringers could provoke these parties to assert counterclaims against us alleging that we infringe their patents, in addition to counterclaims asserting that our patents are invalid or unenforceable, or both. In any patent infringement proceeding, there is a risk that a court will decide that a patent of ours is invalid or unenforceable, in whole or in part, and that we do not have the right to stop the other party from using the invention at issue. There is also a risk that, even if the validity of such patents is upheld, the court will construe the patent's claims narrowly or decide that we do not have the right to stop the other party from using the invention at issue on the grounds that our patent claims do not cover the invention. An adverse outcome in a litigation or proceeding involving our patents could limit our ability to assert our patents against those parties or other competitors and may curtail or preclude our ability to exclude third parties from making and selling similar or competitive products. Any of these occurrences could adversely affect our competitive business position, business prospects and financial condition. Similarly, if we assert trademark infringement claims, a court may determine that the marks we have asserted are invalid or unenforceable, or that the party against whom we have asserted trademark infringement has superior rights to the marks in question. In this case, we could ultimately be forced to cease use of such trademarks.

Even if we establish infringement, the court may decide not to grant an injunction against further infringing activity and instead award only monetary damages, which may or may not be an adequate remedy. Furthermore, because of the substantial amount of discovery required in connection with intellectual property litigation, there is a risk that some of our confidential information could be compromised by disclosure during litigation. There could also be public announcements of the results of hearings, motions or other interim proceedings or developments. If securities analysts or investors perceive these results to be negative, it could have a material adverse effect on the price of shares of our common stock. Moreover, there can be no assurance that we will have sufficient financial or other resources to file and pursue such infringement claims, which typically last for years before they are concluded. Even if we ultimately prevail in such claims, the monetary cost of such litigation and the diversion of the attention of our management and scientific personnel could outweigh any benefit we receive as a result of the proceedings.

***We may rely on trade secret and proprietary know-how which can be difficult to trace and enforce and, if we are unable to protect the confidentiality of our trade secrets, our business and competitive position would be harmed.***

We also rely on trade secrets to protect technology, especially where patent protection is not believed to be appropriate or obtainable or where patents have not issued. For example, our manufacturing process involves a number of trade secret steps, processes, and conditions. Trade secrets and know-how can be difficult to protect. We attempt to protect our proprietary technology and processes, in part, with confidentiality agreements and assignment of invention agreements with our employees and confidentiality agreements with our consultants and certain contractors. Despite these efforts, any of these parties may breach the agreements and disclose our proprietary information, including our trade secrets, and we may not be able to obtain adequate remedies for such breaches. Any disclosure, either intentional or unintentional, by our employees, the employees of third parties with whom we share our facilities or third-party consultants and vendors that we engage to perform research, clinical studies or manufacturing activities, or misappropriation by third parties (such as through a cybersecurity breach) of our trade secrets or proprietary information could enable competitors to duplicate or surpass our technological achievements, thus eroding our competitive position in our market.

Enforcing a claim that a party illegally disclosed or misappropriated a trade secret is difficult, expensive and time-consuming, and the outcome is unpredictable. In addition, some courts inside and outside the United States are less willing or unwilling to protect trade secrets. If any of our trade secrets were to be lawfully obtained or independently developed by a competitor or other third-party, we would have no right to prevent them from using that technology or information to compete with us. If any of our trade secrets were to be disclosed to or independently developed by a competitor or other third-party, our competitive position would be harmed.

There can be no assurance that these agreements are valid and enforceable, will not be breached, that we would have adequate remedies for any breach, or that our trade secrets will not otherwise become known or be independently discovered by competitors. We may fail in certain circumstances to obtain the necessary confidentiality agreements or assignment of invention agreements, or their scope or term may not be sufficiently broad to protect our interests or transfer adequate rights to us.



If our trade secrets or other intellectual property become known to our competitors, it could result in a material adverse effect on our business, financial condition and results of operations. To the extent that we or our consultants or research collaborators use intellectual property owned by others in work for us, disputes may also arise as to the rights to related or resulting know-how and inventions.

***The patent protection and patent prosecution for some of our product candidates is dependent or may be dependent in the future on third parties.***

While we normally seek and gain the right to fully prosecute the patents relating to our product candidates, there may be times when platform technology patents or product-specific patents that relate to our product candidates are controlled by our licensors. In addition, our licensors and/or licensees may have back-up rights to prosecute patent applications in the event that we do not do so or choose not to do so, and our licensees may have the right to assume patent prosecution rights after certain milestones are reached. If any of our licensing collaborators fails to appropriately prosecute and maintain patent protection for patents covering any of our product candidates, our ability to develop and commercialize those product candidates may be adversely affected and we may not be able to prevent competitors from making, using and selling competing products.

***We may not be able to protect our intellectual property rights throughout the world.***

Patents are of national or regional effect, and filing, prosecuting and defending patents on all of our product candidates throughout the world would be prohibitively expensive. As such, we may not be able to prevent third parties from practicing our inventions in all countries outside the United States, or from selling or importing products made using our inventions in and into the United States or other jurisdictions. Further, the legal systems of certain countries, particularly certain developing countries, do not favor the enforcement of patents and other intellectual property protection, particularly those relating to pharmaceuticals or biologics, which could make it difficult for us to stop the infringement of our patents or marketing of competing products in violation of our proprietary rights generally. In addition, certain developing countries, including China and India, have compulsory licensing laws under which a patent owner may be compelled to grant licenses to third parties. In those countries, we and our licensors may have limited remedies if patents are infringed or if we or our licensors are compelled to grant a license to a third-party, which could materially diminish the value of those patents. This could limit our potential revenue opportunities. Accordingly, our efforts to enforce our intellectual property rights around the world may be inadequate to obtain a significant commercial advantage from the intellectual property that we develop or license.

***Patent terms may be inadequate to protect our competitive position on our product candidates for an adequate amount of time.***

Patent rights are of limited duration. Given the amount of time required for the development, testing and regulatory review of new product candidates, patents protecting such candidates might expire before or shortly after such product candidates are commercialized. Even if patents covering our product candidates are obtained, once the patent life has expired for a product, we may be open to competition from biosimilar or generic products. A patent term extension based on regulatory delay may be available in the U.S. However, only a single patent can be extended for each marketing approval, and any patent can be extended only once, for a single product. Moreover, the scope of protection during the period of the patent term extension does not extend to the full scope of the claim, but instead only to the scope of the product as approved. Laws governing analogous patent term extensions in foreign jurisdictions vary widely, as do laws governing the ability to obtain multiple patents from a single patent family. Additionally, we may not receive an extension if we fail to apply within applicable deadlines, fail to apply prior to expiration of relevant patents or otherwise fail to satisfy applicable requirements. If we are unable to obtain patent term extension or restoration, or the term of any such extension is less than we request, the period during which we will have the right to exclusively market our product will be shortened and our competitors may obtain approval of competing products following our patent expiration, and our revenue could be reduced, possibly materially.

***We may be subject to claims by third parties asserting that our employees or we have misappropriated their intellectual property, or claiming ownership of what we regard as our own intellectual property.***

Some of our employees and our licensors' employees, including our senior management, were previously employed at universities or at other biotechnology or pharmaceutical companies, including our competitors or potential competitors. Some of these employees may have executed proprietary rights, non-disclosure and non-competition agreements, or similar agreements, in connection with such previous employment. Although we try to ensure that our employees do not use the proprietary information or know-how of others in their work for us, we may be subject to claims that we or these employees have used or disclosed intellectual property, including

trade secrets or other proprietary information, of any such third-party. Litigation may be necessary to defend against such claims. If we fail in defending any such claims, in addition to paying monetary damages, we may lose valuable intellectual property rights or personnel or sustain damages. Such intellectual property rights could be awarded to a third-party, and we could be required to obtain a license from such third-party to commercialize our technology or products. Such a license may not be available on commercially reasonable terms or at all. Even if we are successful in defending against such claims, litigation could result in substantial costs and be a distraction to management.

In addition, while we typically require our employees, consultants and contractors who may be involved in the development of intellectual property to execute agreements assigning such intellectual property to us, we may be unsuccessful in executing such an agreement with each party who in fact develops intellectual property that we regard as our own, which may result in claims by or against us related to the ownership of such intellectual property. If we fail in prosecuting or defending any such claims, in addition to paying monetary damages, we may lose valuable intellectual property rights. Even if we are successful in prosecuting or defending against such claims, litigation could result in substantial costs and be a distraction to our senior management and scientific personnel.

***Obtaining and maintaining our patent protection depends on compliance with various procedural, document submissions, fee payment and other requirements imposed by governmental patent agencies, and our patent protection could be reduced or eliminated for non-compliance with these requirements.***

Periodic maintenance fees on any issued patent are due to be paid to the USPTO and foreign patent agencies in several stages over the lifetime of the patent. The USPTO and various foreign governmental patent agencies require compliance with a number of procedural, documentary, fee payment and other similar provisions during the patent application process. While an inadvertent lapse can in many cases be cured by payment of a late fee or by other means in accordance with the applicable rules, there are situations in which noncompliance can result in abandonment or lapse of the patent or patent application, resulting in partial or complete loss of patent rights in the relevant jurisdiction. Non-compliance events that could result in abandonment or lapse of a patent or patent application include, but are not limited to, failure to respond to official actions within prescribed time limits, non-payment of fees and failure to properly legalize and submit formal documents. If we fail to maintain the patents and patent applications covering our product candidates, our competitive position would be adversely affected.

#### **Risks Related to Owning our Common Stock**

***The price of our common stock may fluctuate substantially.***

You should consider an investment in our common stock to be risky, and you should invest in our common stock only if you can withstand a significant loss and wide fluctuations in the market value of your investment. Some factors that may cause the market price of our common stock to fluctuate, in addition to the other risks mentioned in this “Risk Factors” section, are:

- sale of our common stock by our stockholders, executives, and directors;
- volatility and limitations in trading volumes of our shares of common stock;
- our ability to obtain financings to conduct and complete research and development activities including, but not limited to, our human clinical trials, and other business activities;
- our announcements or our competitors’ announcements regarding new products or services, enhancements, significant contracts, acquisitions or strategic investments;
- failures to meet external expectations or management guidance;
- clinical trial progress and outcomes;
- changes in our capital structure or dividend policy;
- our cash position and substantial doubt about our ability to continue as a going concern;

## [Table of Contents](#)

- announcements and events surrounding financing efforts, including debt and equity securities;
- our inability to enter into new markets or develop new products;
- reputational issues;
- announcements of acquisitions, partnerships, collaborations, joint ventures, new products, capital commitments, or other events by us or our competitors;
- changes in general economic, political and market conditions in any of the regions in which we conduct our business;
- changes in industry conditions or perceptions;
- changes in valuations of similar companies or groups of companies;
- analyst research reports, recommendation and changes in recommendations, price targets, and withdrawals of coverage;
- departures and additions of key personnel;
- disputes and litigations related to contractual obligations;
- changes in applicable laws, rules, regulations, or accounting practices and other dynamics;
- catastrophic weather and/or global disease outbreaks, such as the recent COVID-19 pandemic; and or
- other events or factors, many of which may be out of our control.

In addition, if the market for stocks in our industry or industries related to our industry, or the stock market in general, experiences a loss of investor confidence, the trading price of our common stock could decline for reasons unrelated to our business, financial condition and results of operations. If any of the foregoing occurs, it could cause our stock price to fall and may expose us to lawsuits that, even if unsuccessful, could be costly to defend and a distraction to management.

The stock market in general has recently experienced relatively large price and volume fluctuations, particularly in response to the COVID-19 outbreak. In particular, the market prices of securities of smaller biotechnology and medical device companies have experienced dramatic fluctuations that often have been unrelated or disproportionate to the operating results of these companies. Continued market fluctuations could result in extreme volatility in the price of our common stock, which could cause a decline in the value of our common stock. In addition, price volatility may increase if the trading volume of our common stock remains limited or declines

***Our 10% or more stockholders and management own a significant percentage of our stock and will be able to exercise significant influence over matters subject to stockholder approval.***

As of December 31, 2021, our executive officers, directors and 10% or more stockholders, together with their respective affiliates, beneficially owned approximately 8.2% of our outstanding securities. Accordingly, this group of security holders will be able to exert a significant degree of influence over our management and affairs and over matters requiring security holder approval, including the election of our Board of Directors, future issuances of our securities, declaration of dividends and approval of other significant corporate transactions. This concentration of ownership could have the effect of delaying or preventing a change-of-control of the Company or otherwise discouraging a potential acquirer from attempting to obtain control of us, which in turn could have a material and adverse effect on the fair market value of our securities. In addition, this significant concentration of share ownership may adversely affect the trading price for our common stock if investors perceive disadvantages in owning stock in a company with such concentrated ownership.

***Our ability to use our net operating loss carry-forwards and certain other tax attributes is limited by Sections 382 and 383 of the Internal Revenue Code.***

Net operating loss carryforwards allow companies to use past year net operating losses to offset against future years' profits, if any, to reduce future tax liabilities. Sections 382 and 383 of the Internal Revenue Code of 1986 limit a corporation's ability to utilize its net operating loss carryforwards and certain other tax attributes (including research credits) to offset any future taxable income or tax if the corporation experiences a cumulative ownership change of more than 50% over any rolling three year period. State net operating loss carryforwards (and certain other tax attributes) may be similarly limited. An ownership change can therefore result in significantly greater tax liabilities than a corporation would incur in the absence of such a change and any increased liabilities could adversely affect the corporation's business, results of operations, financial condition and cash flow.

Ownership changes may occur in the future as a result of additional equity offerings or events over which we will have little or no control, including purchases and sales of our equity by our five percent security holders, the emergence of new five percent security holders, redemptions of our securities or certain changes in the ownership of any of our five percent security holders.

***U.S. federal income tax reform could adversely affect us.***

On December 22, 2017, President Trump signed into law the "Tax Cuts and Jobs Act," or TCJA, that significantly reforms the Internal Revenue Code of 1986, as amended. The TCJA, among other things, includes changes to U.S. federal tax rates, imposes significant additional limitations on the deductibility of interest, allows for the expensing of capital expenditures, a reduction to the maximum deduction allowed for net operating losses generated in tax years after December 31, 2017, and puts into effect the migration from a "worldwide" system of taxation to a partially territorial system. We do not expect tax reform to have a material impact to our projection of minimal cash taxes or to our net operating losses. Our net deferred tax assets and liabilities will be revalued at the newly enacted U.S. corporate rate, and the impact will be recognized in our tax expense in the year of enactment. Further, any eligibility we may have or may someday have for tax credits associated with the qualified clinical testing expenses arising out of the development of orphan drugs will be reduced to 25% as a result of the TCJA; thus, our net taxable income may be affected. We continue to examine the impact this tax reform legislation may have on our business. The impact of this tax reform on holders of our common stock is uncertain and could be adverse. This annual report on Form 10-K does not discuss any such tax legislation or the manner in which it might affect purchasers of our common stock. We urge our stockholders, to consult with their legal and tax advisors with respect to such legislation and the potential tax consequences of investing in our common stock.

***Future sales and issuances of our common stock or rights to purchase common stock pursuant to our equity incentive plan could result in additional dilution of the percentage ownership of our stockholders and could cause our share price to fall.***

We expect that significant additional capital will be needed in the future to continue our planned operations, including expanding research and development, funding clinical trials, purchasing of capital equipment, hiring new personnel, commercializing our products, and continuing activities as an operating public company. To the extent we raise additional capital by issuing equity securities, our stockholders may experience substantial dilution. We may sell common stock, convertible securities or other equity securities in one or more transactions at prices and in a manner, we determine from time to time. If we sell common stock, convertible securities or other equity securities in more than one transaction, investors may be materially diluted by subsequent sales. Such sales may also result in material dilution to our existing stockholders, and new investors could gain rights superior to our existing stockholders.

***We do not intend to pay cash dividends on our shares of common stock so any returns will be limited to the value of our shares.***

We currently anticipate that we will retain future earnings for the development, operation and expansion of our business and do not anticipate declaring or paying any cash dividends for the foreseeable future. Any return to stockholders will therefore be limited to the increase, if any, of our share price.

***We are an "emerging growth company" and will be able to avail ourselves of reduced disclosure requirements applicable to emerging growth companies, which could make our common stock less attractive to investors.***

We are an "emerging growth company," as defined in the Jumpstart Our Business Startups Act of 2012, or the JOBS Act, and we intend to take advantage of certain exemptions from various reporting requirements that are applicable to other public companies that are not "emerging growth companies" including not being required to comply with the auditor attestation requirements of

Section 404(b) of the Sarbanes-Oxley Act, reduced disclosure obligations regarding executive compensation in our periodic reports and proxy statements, and exemptions from the requirements of holding a nonbinding advisory vote on executive compensation and stockholder approval of any golden parachute payments not previously approved. In addition, Section 107 of the JOBS Act also provides that an “emerging growth company” can take advantage of the extended transition period provided in Section 7(a)(2)(B) of the Securities Act, for complying with new or revised accounting standards. In other words, an “emerging growth company” can delay the adoption of certain accounting standards until those standards would otherwise apply to private companies. We are electing to delay such adoption of new or revised accounting standards, and as a result, we may not comply with new or revised accounting standards on the relevant dates on which adoption of such standards is required for non-emerging growth companies. As a result of such election, our consolidated financial statements may not be comparable to the financial statements of other public companies. We cannot predict if investors will find our common stock less attractive because we may rely on these exemptions. If some investors find our common stock less attractive as a result, there may be a less active trading market for our common stock and our stock price may be more volatile. We may take advantage of these reporting exemptions until we are no longer an “emerging growth company.” We will remain an “emerging growth company” until the earliest of (i) the last day of the fiscal year in which we have total annual gross revenues of \$1.07 billion or more; (ii) the last day of our fiscal year following the fifth anniversary of the date of the completion of our initial public offering; (iii) the date on which we have issued more than \$1 billion in nonconvertible debt during the previous three years; or (iv) the date on which we are deemed to be a large accelerated filer under the rules of the Securities and Exchange Commission.

***Because we have elected to defer compliance with new or revised accounting standards, our financial statement disclosure may not be comparable to similar companies.***

We have elected to use the extended transition period for complying with new or revised accounting standards under Section 102(b)(1) of the JOBS Act. This allows us to delay the adoption of new or revised accounting standards that have different effective dates for public and private companies until those standards apply to private companies. As a result of our election, our consolidated financial statements may not be comparable to companies that comply with public company effective dates.

Because of this extended transition period, we may be less attractive to investors and it may be difficult for us to raise additional capital as and when we need it. Investors may be unable to compare our business with other companies in our industry if they believe that our financial accounting is not as transparent as other companies in our industry. If we are unable to raise additional capital as and when we need it, our financial condition and results of operations may be materially and adversely affected.

***We may be at risk of securities class action litigation.***

We may be at risk of securities class action litigation. This risk is especially relevant for us due to our dependence on positive clinical trial outcomes and regulatory approvals of each of our product candidates. In the past, biotechnology and pharmaceutical companies have experienced significant stock price volatility, particularly when associated with binary events such as clinical trials and product approvals. If we face such litigation, it could result in substantial costs and a diversion of management’s attention and resources, which could harm our business and results in a decline in the market price of our common stock.

***Our management will be required to devote substantial time to compliance initiatives.***

As a public company, we incur significant legal, accounting, and other expenses that we did not incur as a newly formed entity. The Sarbanes-Oxley Act, as well as rules subsequently implemented by the SEC and The Nasdaq Capital Market, have imposed various new requirements on public companies, including requiring establishment and maintenance of effective disclosure and financial controls and changes in corporate governance practices. Our management and other personnel will need to devote a substantial amount of time to these new compliance initiatives. Moreover, these rules and regulations will increase our legal and financial compliance costs and will make some activities more time consuming and costly. We expect these rules and regulations to make it more difficult and more expensive for us to obtain director and officer liability insurance and we may be required to incur substantial costs to maintain the same or similar coverage.

***Our common stock may be delisted if we fail to comply with continued listing standards.***

If we fail to meet any of the continued listing standards of The Nasdaq Capital Market, our common stock could be delisted from The Nasdaq Capital Market. These continued listing standards include specifically enumerated criteria, such as:

- a \$1.00 minimum closing bid price;
- stockholders' equity of \$2.5 million;
- 500,000 shares of publicly-held common stock with a market value of at least \$1 million;
- 300 round-lot stockholders; and
- compliance with Nasdaq's corporate governance requirements, as well as additional or more stringent criteria that may be applied in the exercise of Nasdaq's discretionary authority.

If we fail to comply with Nasdaq's continued listing standards, we may be delisted and our common stock will trade, if at all, only on the over-the-counter market, such as the OTC Bulletin Board or OTCQX market, and then only if one or more registered broker-dealer market makers comply with quotation requirements. In addition, delisting of our common stock could depress our stock price, substantially limit liquidity of our common stock and materially adversely affect our ability to raise capital on terms acceptable to us, or at all. Finally, delisting of our common stock could result in our common stock becoming a "penny stock" under the Exchange Act.

***Upon our dissolution, you may not recoup all or any portion of your investment.***

In the event of a liquidation, dissolution or winding-up of us, whether voluntary or involuntary, the proceeds and/or our assets may not be sufficient to repay the aggregate investment you purchased in our company. In this event, you could lose some or all of your investment.

***We have identified a material weakness in our internal control over financial reporting. Failure to maintain effective internal controls could cause our investors to lose confidence in us and adversely affect the market price of our common stock. If our internal controls are not effective, we may not be able to accurately report our financial results or prevent fraud.***

Effective internal control over financial reporting is necessary for us to provide reliable financial reports in a timely manner. In connection with the preparation of our consolidated financial statements for the year ended December 31, 2021, we concluded that there was a material weakness in our internal control over financial reporting. A material weakness is a deficiency, or a combination of deficiencies, in internal control over financial reporting such that there is a reasonable possibility that a material misstatement of our annual or interim consolidated financial statements will not be prevented or detected on a timely basis. We have identified a material weakness in our internal controls resulting from our finance department not being able to process complex, non-routine transactions in a timely manner.

While we have designed and implemented, or expect to implement, measures that we believe address or will address this control weakness, we continue to develop our internal controls, processes and reporting systems by, among other things, hiring qualified personnel with expertise to perform specific functions, and designing and implementing improved processes and internal controls, including ongoing senior management review and audit committee oversight. We plan to remediate the identified material weakness by hiring financial consultants and expect to hire additional senior accounting staff to complete the remediation by the end of 2022. We expect to incur additional costs to remediate this weakness, primarily personnel costs and external consulting fees. We may not be successful in implementing these systems or in developing other internal controls, which may undermine our ability to provide accurate, timely and reliable reports on our financial and operating results. Further, we will not be able to fully assess whether the steps we are taking will remediate the material weakness in our internal control over financial reporting until we have completed our implementation efforts and sufficient time passes in order to evaluate their effectiveness. In addition, if we identify additional material weaknesses in our internal control over financial reporting, we may not detect errors on a timely basis and our consolidated financial statements may be materially misstated. Moreover, in the future we may engage in business transactions, such as acquisitions, reorganizations or

implementation of new information systems that could negatively affect our internal control over financial reporting and result in material weaknesses.

Our independent registered public accounting firm did not perform an evaluation of our internal control over financial reporting during any period in accordance with the provisions of the Sarbanes-Oxley Act. Had our independent registered public accounting firm performed an evaluation of our internal control over financial reporting in accordance with the provisions of the Sarbanes-Oxley Act, additional control deficiencies amounting to material weaknesses might have been identified. If we identify new material weaknesses in our internal control over financial reporting, if we are unable to comply with the requirements of Section 404 of the Sarbanes-Oxley Act in a timely manner, if we are unable to assert that our internal control over financial reporting is effective, or if our independent registered public accounting firm is unable to express an opinion as to the effectiveness of our internal control over financial reporting, we may be late with the filing of our periodic reports, investors may lose confidence in the accuracy and completeness of our financial reports and the market price of our common stock could be negatively affected. As a result of such failures, we could also become subject to investigations by the stock exchange on which our securities are listed, the SEC, or other regulatory authorities, and become subject to litigation from investors and stockholders, which could harm our reputation, financial condition or divert financial and management resources from our core business.

**Item 1B. Unresolved Staff Comments**

Not applicable.

**Item 2. Properties**

Our corporate headquarters are currently located in Los Gatos, California, where we occupy approximately 15,129 gross square feet of office and laboratory space under a lease that will expire in January 2026 with a three-year renewal option.

**Item 3. Legal Proceedings**

A complaint was filed on February 18, 2020 in the New York State Supreme Court against us by an investor who invested in our company's preferred stock in July 2017 which was prior to our initial public offering in August 2018. The complaint alleges, among other things, that we breached our contract and fiduciary duty, by not issuing additional securities to the investor as a result of our initial public offering. The plaintiff is asking for approximately \$277,000 in compensatory damages. The parties are currently in fact discovery. We believe that all of the claims in the complaint are without merit and intend to defend vigorously against them.

On September 1, 2021, Cantor Fitzgerald & Co. ("Cantor") filed a complaint in the New York State Supreme Court against us alleging that we breached a letter agreement with Cantor and owe Cantor approximately \$1.8 million, including attorney's fees for a financing fee related to our equity offering in August 2021. The parties entered into a settlement agreement and release on December 15, 2021.

The Company submitted a complaint in Superior Court of the State of California, County of Santa Clara, against our former landlord on October 22, 2021, asserting claims for breach of contract, breach of the covenant of good faith and fair dealing, wrongful eviction/constructive eviction and unjust enrichment and violation of the unfair competition law. The claims arise from rent increases and the termination of the tenancy that we allege were not permitted by the agreement with the landlord. We seek to recover rent paid under protest, our deposit, moving and relocation expenses and consequential damages arising from disruption to our operations. The landlord has filed a cross-complaint for damage to property and attorneys' fees.

**Item 4. Mine Safety Disclosures**

Not applicable.

## **PART II**

### **Item 5. Market for Registrant’s Common Equity, Related Stockholder Matters and Issuer Purchases of Equity Securities**

#### **Market Information**

On August 14, 2018, our common stock began trading on the Nasdaq Capital Market under the symbol “ARDS”. Prior to that time, there was no public market for our common stock.

#### **Stockholders**

As of March 25, 2022, there were 81 stockholders of record of our common stock. The actual number of holders of our common stock is greater than this number of record holders, and includes stockholders who are beneficial owners, but whose shares are held in street name by brokers or held by other nominees.

#### **Dividend Policy**

We have never paid or declared any cash dividends on our common stock, and we do not anticipate paying any cash dividends on our common stock in the foreseeable future. We intend to retain all available funds and any future earnings to fund the development and expansion of our business. Any future determination to pay dividends will be at the discretion of our board of directors and will depend upon a number of factors, including our results of operations, financial condition, future prospects, contractual restrictions, restrictions imposed by applicable law and other factors that our board of directors deems relevant.

#### **Equity Compensation Plans**

The information required by Item 5 of Form 10-K regarding equity compensation plans is incorporated herein by reference to Item 11 of Part III of this Annual Report.

### **Item 6. Selected Financial Data**

Not applicable.



## Item 7. Management’s Discussion and Analysis of Financial Condition and Results of Operations

### MANAGEMENT’S DISCUSSION AND ANALYSIS OF FINANCIAL CONDITION AND RESULTS OF OPERATIONS

*The following discussion and analysis should be read in conjunction with our consolidated financial statements and related notes included elsewhere in this Annual Report. This discussion and analysis and other parts of this Annual Report contain forward-looking statements based upon current beliefs, plans and expectations that involve risks, uncertainties and assumptions, such as statements regarding our plans, objectives, expectations, intentions and projections. Our actual results and the timing of selected events could differ materially from those anticipated in these forward-looking statements as a result of several factors, including those set forth under “Risk Factors” and elsewhere in this Annual Report. You should carefully read the “Risk Factors” section of this Annual Report to gain an understanding of the important factors that could cause actual results to differ materially from our forward-looking statements. Please also see the section entitled “Cautionary Note Concerning Forward-Looking Statements.” All amounts in this report are in U.S. dollars, unless otherwise noted.*

#### Overview

We are a late-stage biopharmaceutical company focused on the discovery and development of novel anti-infectives. A significant focus of ours is on targeted immunotherapy using fully human monoclonal antibodies, or mAbs, to treat life-threatening infections. mAbs represent an innovative treatment approach that harnesses the human immune system to fight infections and are designed to overcome the deficiencies associated with current therapies, such as rise in drug resistance, short duration of response, limited tolerability, negative impact on the human microbiome, and lack of differentiation among the treatment alternatives. The majority of our product candidates are derived by employing our differentiated antibody discovery platforms. Our proprietary product pipeline comprises fully human mAbs targeting specific pathogens associated with life-threatening bacterial infections, primarily nosocomial pneumonia, and viral infections such as COVID-19.

Our APEX™ production platform technology enables the screening of a large number of antibody-producing B-cells from patients and generation of high mAb-producing mammalian production cell line at a speed not previously attainable. As a result, we can significantly reduce time for antibody discovery and manufacturing compared to conventional approaches. This technology is being applied to the development of COVID-19 mAbs.

In 2021, we announced the development of highly neutralizing monoclonal antibody cocktails AR-712 and AR-701, discovered from convalescent COVID-19 patients, that successfully eliminated all detectable SARS-CoV-2 virus in infected animals at substantially lower doses than parenterally administered (injected) COVID-19 mAbs. The mAb cocktails broadly bind and neutralize SAR-COV-2 virus and the mutant ‘E484K’ variant that is associated with the UK, South Africa, Brazil, and Japan strains. The AR-701 mAb cocktail exhibits broad neutralization to SARS-CoV-2, SARS, MERS, and several seasonal ‘common cold’ coronaviruses. We announced that AR-701 is replacing AR-712 as a clinical track program. The potency of AR-701 and its direct delivery to the lungs by inhaled administration may facilitate broader treatment coverage and dose sparing not achievable by parenteral administration. A clinical Phase 1/2 study is expected to be launched in the second half of 2022.

Our lead product candidate, AR-301 has exhibited promising preclinical data and clinical data from a Phase 1/2a clinical study in patients. AR-301 targets the alpha toxin produced by gram-positive bacteria *Staphylococcus aureus*, or *S. aureus*, a common pathogen associated with HAP and VAP. In contrast to other programs targeting *S. aureus* toxins, we are developing AR-301 as a treatment of pneumonia, rather than prevention of *S. aureus* colonized patients from progression to pneumonia. In January 2019, we initiated a Phase 3 pivotal trial evaluating AR-301 for the treatment of HAP and VAP. The on-going COVID-19 pandemic has and continues to cause an impact on patient enrollment globally and the rate of clinical site activation. We expect to report top line data from this trial in the second half of 2022.

To complement and diversify our portfolio of targeted mAbs, we are developing a broad spectrum small molecule non-antibiotic anti-infective agent gallium citrate (AR-501). AR-501 is being developed in collaboration with the Cystic Fibrosis Foundation (“CFF”) as a chronic inhaled therapy to treat lung infections in cystic fibrosis patients. In 2018, AR-501 was granted Orphan Drug, Fast Track and Qualified Infectious Disease Product (“QIDP”) designations by the Food and Drug Administration (“FDA”). During the third quarter of 2019, the European Medicines Agency (“EMA”) granted the program Orphan Drug Designation. We initiated a Phase 1/2a clinical trial in December 2018 of the inhalable formulation of gallium citrate, which is being evaluated for the treatment of chronic lung

infections associated with cystic fibrosis. In June 2020, we announced positive results from the Phase 1 portion of our Phase 1/2a clinical trial of AR-501 in which healthy subjects were enrolled. The Safety Monitoring Committee (“SMC”) and Data Safety Monitoring Board (“DSMB”) from the Cystic Fibrosis Foundation supported that the study proceed at all dose levels to the Phase 2a portion of the Phase 1/2a trial in adult subjects with cystic fibrosis (“CF”). We expect to complete enrollment in mid-2022 and announce top line results in mid-2022.

In July 2021, we announced an in-licensing agreement with MedImmune Limited, a wholly owned subsidiary of AstraZeneca, for the worldwide commercial rights of suvratoxumab, which is a half-life extended human IgG1 monoclonal antibody that also targets the alpha toxin produced by *S. aureus*. Suvratoxumab is a fully human, IgG1 monoclonal antibody targeting *S. aureus* alpha toxin. This product is given the product code ‘AR-320’. As with AR-301, AR-320’s mode of action is independent of the antibiotic resistance profile of *S. aureus*, and it is active against infections caused by both methicillin-resistant *S. aureus* (“MRSA”) and methicillin-susceptible *S. aureus* (“MSSA”). Suvratoxumab and AR-301 are complementary products. Suvratoxumab’s focus on preventive treatment of *S. aureus* pneumonia complements Aridis’ AR-301 Phase 3 mAb program which is being developed as a therapeutic treatment of *S. aureus* pneumonia. A multinational, randomized, double blinded, placebo controlled Phase 2 study conducted by AstraZeneca (n=196 patients) showed that mechanically ventilated ICU patients colonized with *S. aureus* who are treated with suvratoxumab saw a relative risk reduction of pneumonia by 32% in the overall intend to treat study population, and by 47% in the prespecified under 65 year old population, which is the target population in the planned Phase 3 study. The relative risk reduction in the target population reached statistical significance, and was also associated with a substantial reduction in the duration of care needed in the ICU and hospital [see [https://www.thelancet.com/journals/laninf/article/PIIS1473-3099\(20\)30995-6/fulltext](https://www.thelancet.com/journals/laninf/article/PIIS1473-3099(20)30995-6/fulltext)]. We believe that AR-320 will be first-line treatment, first to market, first-in-class pre-emptive treatment of *S. aureus* colonized patients.

To date, we have devoted substantially all of our resources to research and development efforts relating to our therapeutic candidates, including conducting clinical trials and developing manufacturing capabilities, in-licensing related intellectual property, protecting our intellectual property and providing general and administrative support for these operations. We have generated revenue from our payments under our collaboration strategic research and development contracts and federal awards and grants, as well as awards and grants from not-for-profit entities and fee for service to third-party entities. Since our inception, we have funded our operations primarily through these sources and the issuance of common stock, convertible preferred stock, and debt securities. Current clinical development activities are focused on AR-301, AR712 and AR-501. Our expenses and resulting cash burn during the years ended December 31, 2021 and 2020, were largely due to costs associated with the Phase 3 study of AR-301 for the treatment of VAP caused by the *S. aureus* bacteria, preclinical development of AR-01 COVID-19 mAbs, the preparation of AR-320 for a phase 3 clinical trial that is expected to be initiated in the first half of 2022 and the Phase 1/2 study of AR-501 for the treatment of chronic lung infections associated with cystic fibrosis.

## Financial Overview

We have incurred losses since our inception. Our net losses were approximately \$42.2 million and \$22.3 million for the years ended December 31, 2021 and 2020, respectively. As of December 31, 2021 we had approximately \$20.0 million of cash, cash equivalents and restricted cash and had an accumulated deficit of approximately \$165.3 million. Substantially, all of our net losses have resulted from costs incurred in connection with our research and development programs, clinical trials, intellectual property matters, strengthening our manufacturing capabilities, and from general and administrative costs associated with our operations.

We have not yet achieved commercialization of our products and have a cumulative net loss from our operations. We will continue to incur net losses for the foreseeable future. Our consolidated financial statements have been prepared assuming that we will continue as a going concern. We will require additional capital to meet our long-term operating requirements. We expect to raise additional capital through the sale of equity and/or debt securities. Historically, our principal sources of cash have included proceeds from grant funding, fees for services performed, issuances of debt and the sale of our preferred stock. Our principal uses of cash have included cash used in operations. We expect that the principal uses of cash in the future will be for continuing operations, funding of research and development including our clinical trials and general working capital requirements.

We anticipate that our expenses will increase substantially if and as we:

- continue enrollment in our ongoing clinical trials;
- initiate new clinical trials;

- seek to identify, assess, acquire and develop other products, therapeutic candidates and technologies;
- seek regulatory and marketing approvals in multiple jurisdictions for our therapeutic candidates that successfully complete clinical studies;
- establish collaborations with third parties for the development and commercialization of our products and therapeutic candidates;
- make milestone or other payments under our agreements, pursuant to which we have licensed or acquired rights to intellectual property and technology;
- seek to maintain, protect, and expand our intellectual property portfolio;
- seek to attract and retain skilled personnel;
- incur the administrative costs associated with being a public company and related costs of compliance;
- create additional infrastructure to support our operations as a commercial stage public company and our planned future commercialization efforts;
- experience any delays or encounter issues with any of the above; and
- experience protracted COVID-19 related delays.

We expect to continue to incur significant expenses and losses for at least the next several years. Accordingly, we anticipate that we will need to raise additional capital in order to obtain regulatory approval for, and the commercialization of, our therapeutic candidates. Until such time that we can generate meaningful revenue from product sales, if ever, we expect to finance our operating activities through public or private equity or debt financings, government or other third-party funding and other collaborations, strategic alliances and licensing arrangements or a combination of these approaches. If we are unable to obtain funding on a timely basis, we may be required to significantly curtail, delay or discontinue one or more of our research or development programs or the commercialization of any approved therapies or products or be unable to expand our operations or otherwise capitalize on our business opportunities, as desired, which could adversely affect our business, financial condition and results of operations.

#### ***SIBV License Agreement***

In July 2019, we entered into an option agreement with Serum International B.V. (“SIBV”), an affiliate of Serum Institute of India Private Limited, which granted SIBV the option to license multiple programs from us and access our MabIgX® platform technology for asset identification and selection. We received an upfront cash payment of \$5 million upon execution of this option agreement. In connection with the option agreement, SIBV made an equity investment whereby we issued 801,820 shares of our restricted common stock in a private placement to SIBV for total gross proceeds of \$10 million.

#### ***SAMR License Agreement***

In September 2019, we entered into a License, Development and Commercialization Agreement (the “License Agreement”) with Serum AMR Products (“SAMR”). Pursuant to the License Agreement, we received upfront payments totaling \$15 million, of which \$5 million was received in July 2019 through the option agreement referred to above, and may receive milestone payments and royalty-based payments from SAMR if certain milestones and sales levels as defined in the License Agreement are met.

Given the equity investment by SIBV was negotiated in conjunction with the option agreement, which resulted in the execution of the License Agreement, all arrangements were evaluated as a single agreement and amounts were allocated to the elements of the

arrangement based on their fair value. We allocated the proceeds received from the sale of the restricted common stock and upfront payment from the License Agreement, net of issuance and contract costs, of approximately \$22.5 million accordingly:

- we recorded approximately \$5.0 million, which represented the fair value of the restricted common stock issued of \$5.4 million, net of \$441,000 of issuance costs, to stockholders' equity within our consolidated balance sheet;
- we recorded approximately \$19.6 million to deferred revenue based on the \$15 million from upfront payments under the License Agreement and approximately \$4.6 million from the equity allocation; and
- we capitalized approximately \$2.1 million to contract costs, which consists of approximately \$376,000 issuance costs from the equity allocation and approximately \$1.7 million in other direct costs to obtain the License Agreement.

#### ***CFF License Agreement***

Under the Development Program Letter Agreement with CFF (the "CFF Agreement"), entered into in December 2016 and amended in November 2018 to support funding for the development of our Inhaled Gallium Citrate Anti-Infective program, we recognized revenue of approximately \$0.5 million for the year ended December 31, 2021 and \$1.0 million for the year ended December 31, 2020. We expect that any revenue we generate for the foreseeable future will fluctuate from period to period as a result of the timing of when performance obligations and variable consideration criteria under the contract are satisfied.

#### ***Kermode License Agreement***

Under a product discovery agreement with Kermode Biotechnologies, Inc. ("Kermode"), entered into in February 2021 to fund the discovery of product candidates for African Swine Fever Virus ("ASFV") with an option to include the discovery of product candidates for swine influenza virus ("SIV"). For the year ended December 31, 2021, the Company recognized approximately \$465,000 in revenue related to the Kermode Agreement. The Company has recorded the remaining portion of the nonrefundable upfront payment as a contract liability of approximately \$285,000 to deferred revenue, current, as of December 31, 2021.

#### ***Gates Foundation License Agreement***

On October 15, 2021, the Company entered into a Grant Agreement with the Bill and Melinda Gates Foundation ("Gates Foundation"). The goal of the Grant, is to develop durable approaches to block the infection and transmission of pathogens. For the year ended December 31, 2021, the Company recognized revenue of approximately \$546,000 from the Grant. The Company recorded a contract liability for the remaining consideration of approximately \$1,387,000 to deferred revenue, current, on its consolidated balance sheet as of December 31, 2021.

#### ***Critical Accounting Policies and Estimates***

Our management's discussion and analysis of our financial condition and results of operations is based on our consolidated financial statements, which we have prepared in accordance with generally accepted accounting principles in the United States, or GAAP.

The preparation of our consolidated financial statements requires management to make estimates and assumptions that affect the reported amounts of assets and liabilities and the disclosure of contingent assets and liabilities at the date of the financial statements, as well as the reported expenses during the reported periods. We evaluate these estimates and judgments on an ongoing basis. Such estimates include those related to the evaluation of our ability to continue as a going concern, our best estimate of standalone selling price of revenue deliverables, useful life of long lived assets, classification of deferred revenue, income taxes, assumptions used in the Black Scholes Merton ("BSM") model to calculate the fair value of stock based compensation, deferred tax asset valuation allowances, and preclinical study and clinical trial accruals. We base our estimates on historical experience and on various other factors that we believe are reasonable under the circumstances, the results of which form the basis for making judgments about the carrying value of assets and liabilities that are not readily apparent from other sources. Our actual results may differ from these estimates under different assumptions or conditions.

We define our critical accounting policies as those accounting principles generally accepted in the United States that require us to make subjective estimates and judgments about matters that are uncertain and are likely to have a material impact on our financial condition and results of operations as well as the specific manner in which we apply those principles. Our critical accounting policies are primarily for revenue recognition and accrued research and development costs. We believe the significant accounting policies used in the preparation of our consolidated financial statements are as follows:

### ***Revenue Recognition***

We recognize revenue based on Accounting Standards Codification (“ASC”) 606, *Revenue from Contracts with Customers* (“ASC 606”), which applies to all contracts with customers, except for contracts that are within the scope of other standards, such as leases, insurance, collaboration arrangements and financial instruments.

To determine revenue recognition for arrangements that we determine are within the scope of ASC 606, we perform the following five steps: (i) identify the contract(s) with a customer; (ii) identify the performance obligations in the contract; (iii) determine the transaction price; (iv) allocate the transaction price to the performance obligations in the contract; and (v) recognize revenue at a point in time, or over time, as the entity satisfies performance obligations. We only apply the five-step model to contracts when it is probable that we will collect the consideration it is entitled to in exchange for the goods or services we transfer to the customer. At contract inception, once the contract is determined to be within the scope of ASC 606, we assess the goods or services promised within each contract, determine those that are performance obligations, and assess whether each promised good or service is distinct. We then recognize as revenue the amount of the transaction price that is allocated to the respective performance obligation when (or as) the performance obligation is satisfied.

As part of the accounting for customer arrangements, we must use judgment to determine: a) the number of performance obligations based on the determination under step (ii) above; b) the transaction price under step (iii) above; and c) the standalone selling price for each performance obligation identified in the contract for the allocation of the transaction price in step (iv) above. We use judgment to determine whether milestones or other variable consideration should be included in the transaction price.

The transaction price is allocated to each performance obligation on a relative standalone selling price basis. In developing the standalone price for a performance obligation, we consider applicable market conditions and relevant entity-specific factors, including factors that were contemplated in negotiating the agreement with the customer and estimated costs. We recognize revenue as or when the performance obligations under the contract are satisfied. We receive payments from our customers based on payment schedules established in each contract. We record any amounts received prior to satisfying the revenue recognition criteria as deferred revenue on the consolidated balance sheet. Amounts recognized as revenue, but not yet received or invoiced are recorded within other receivables on the consolidated balance sheet. Amounts are recorded as other receivables on the consolidated balance sheet when our right to consideration is unconditional. We do not assess whether a contract has a significant financing component if the expectation at contract inception is such that the period between payment by the customer and the transfer of a majority of the promised goods or services to the customer will be one year or less.

### ***Research and Development Expenses***

We recognize research and development expenses to operations as they are incurred. Our research and development expenses consist primarily of:

- salaries and related overhead expenses, which include stock-based compensation and benefits for personnel in research and development functions;
- fees paid to consultants and contract research organizations, or CROs, including in connection with our preclinical studies and clinical trials and other related clinical trial fees, such as for investigator grants, patient screening, laboratory work, clinical trial material management and statistical compilation and analyses;
- costs related to acquiring and manufacturing clinical trial materials;
- costs related to compliance with regulatory requirements; and

- payments related to licensed products and technologies.

Costs for certain development activities are recognized based on an evaluation of the progress to completion of specific tasks using information and data provided to us by our vendors and clinical sites. Nonrefundable advance payments for goods or services to be received in future periods for use in research and development activities are deferred and capitalized. The capitalized amounts are then expensed as the related goods are delivered or when the services are performed.

We plan to increase our research and development expenses for the foreseeable future as we continue to develop our therapeutic programs, and subject to the availability of additional funding, further advance the development of our therapeutic candidates for additional indications and begin to conduct clinical trials.

The process of conducting the necessary clinical research to obtain regulatory approval is costly and time-consuming, and the successful development of our therapeutic candidates is highly uncertain. As a result, we are unable to determine the duration and completion costs of our research and development projects or when and to what extent we will generate revenue from the commercialization and sale of any of our therapeutic candidates.

### ***Stock-Based Compensation***

We recognize compensation expense for all stock-based awards based on the grant-date estimated fair values, which we determine using the BSM option pricing model, on a straight-line basis over the requisite service period for the award. We account for forfeitures as they occur.

The BSM option pricing model incorporates various highly sensitive assumptions, including the fair value of our common stock, expected volatility, expected term and risk-free interest rates. The weighted average expected life of options was calculated using the simplified method as prescribed by the SEC's Staff Accounting Bulletin, Topic 14 ("SAB Topic 14"). This decision was based on the lack of relevant historical data due to our limited historical experience. In addition, due to our limited historical data, the estimated volatility also reflects the application of SAB Topic 14, incorporating the historical volatility of comparable companies whose stock prices are publicly available. The risk-free interest rate for the periods within the expected term of the option is based on the U.S. Treasury yield in effect at the time of grant. The dividend yield was zero, as we have never declared or paid dividends and have no plans to do so in the foreseeable future.

### ***Income Taxes***

We account for income taxes under the liability method. Under this method, deferred tax assets and liabilities are determined based on the difference between the financial statement and tax bases of assets and liabilities using enacted tax rates in effect for the year in which the differences are expected to affect taxable income. Valuation allowances are established when necessary to reduce deferred tax assets to the amounts expected to be realized. For the years ended December 31, 2021 and 2020, no income tax expense or benefit was recognized, primarily due to a full valuation allowance recorded against the net deferred tax asset.

We assess all material positions taken in any income tax return, including all significant uncertain positions, in all tax years that are still subject to assessment or challenge by the relevant taxing authorities. Assessing an uncertain tax position begins with the initial determination of the position's sustainability and is measured at the largest amount of benefit that is greater than fifty percent likely of being realized upon ultimate settlement. At each balance sheet date, unresolved uncertain tax positions must be reassessed, and we determine whether (i) the factors underlying the sustainability assertion have changed and (ii) the amount of the recognized benefit is still appropriate. The recognition and measurement of tax benefits requires significant judgment. Judgments concerning the recognition and measurement of a tax benefit might change as new information becomes available.

### ***Going Concern***

We assess and determine our ability to continue as a going concern under the provisions of ASC 205-40, *Presentation of Financial Statements—Going Concern*, which requires us to evaluate whether there are conditions or events that raise substantial doubt about our ability to continue as a going concern within one year after the date that our annual and interim consolidated financial statements are issued. Certain additional financial statement disclosures are required if such conditions or events are identified. If and when an entity's liquidation becomes imminent, financial statements should be prepared under the liquidation basis of accounting.

Determining the extent, if any, to which conditions or events raise substantial doubt about our ability to continue as a going concern, or the extent to which mitigating plans sufficiently alleviate any such substantial doubt, as well as whether or not liquidation is imminent, requires significant judgment by us. We have determined that there is substantial doubt about our ability to continue as a going concern for at least the one-year period following our consolidated financial statements issuance date, which have been prepared assuming that we will continue as a going concern. We have not made any adjustments to reflect the possible future effects on the recoverability and classification of assets or the amounts and classification of liabilities that may result from the possible inability of us to continue as a going concern.

## Results of Operations

### Comparison of the Years Ended December 31, 2021 and 2020

The following table summarizes our results of operations for the years ended December 31, 2021 and 2020 (in thousands):

	Year Ended December 31,		Change
	2021	2020	
Revenue:			
Grant revenue	\$ 1,535	\$ 1,000	\$ 535
Operating expenses:			
Research and development	36,936	16,956	19,980
General and administrative	7,310	6,445	865
Total operating expenses	44,246	23,401	20,845
Loss from operations	(42,711)	(22,401)	(20,310)
Other (expense) income:			
Interest (expense) income, net	(245)	77	(322)
Other income	74	—	74
Gain on extinguishment of Paycheck Protection Program loan	722	—	722
Change in fair value of note payable	(33)	—	(33)
Share of loss from equity method investment	—	(9)	9
Net loss	<u>\$ (42,193)</u>	<u>\$ (22,333)</u>	<u>\$ (19,860)</u>

*Grant Revenue.* Grant revenue increased by approximately \$0.5 million for the year ended December 31, 2021 primarily related to the recognition of revenue from the CFF, Gates Foundation and Kermode during 2021 and revenue from CFF in 2020.

*Research and Development Expenses.* Research and development expenses increased by approximately \$20.0 million to \$36.9 million for year ended December 31, 2021 from \$17.0 million for the year ended December 31, 2020 due primarily to:

- an increase of approximately \$11.5 million to in-license AR-320 rights from Medimmune;
- an increase of approximately \$5.6 million for AR-320 drug manufacture and clinical trial oversight costs;
- an increase of approximately \$0.7 million for SARS-CoV2 antibody exclusive license;
- an increase of approximately \$0.5 million for CFF project; and
- an increase of approximately \$0.6 million in personnel, consulting and other related costs;

*General and Administrative Expenses.* General and administrative expenses increased by approximately \$0.9 million to \$7.3 million for the year ended December 31, 2021 from \$6.4 million for the year ended December 31, 2020 due primarily to increases in professional service fees, franchise tax and recruitment expense to attract talent.

*Interest Expense, Net.* Interest expense, net for the year ended December 31, 2021 consists primarily of the original issue discount on the Note Purchase Agreement with Streeterville Capital, LLC. Interest income, net consists primarily of interest earned on our cash balances for the year ended December 31, 2020.

*Gain on extinguishment of Paycheck Protection Program loan.* This relates to the forgiveness of this loan during the year ended December 31, 2021.

*Change in fair value of note payable.* This relates primarily to the change in fair value of the note payable pursuant to the Note Purchase Agreement with Streeterville Capital, LLC for the year ended December 31, 2021.

*Share of Loss in Equity Method Investment.* Loss from equity method investment decreased by approximately \$9,000 to zero for the year ended December 31, 2021 from \$9,000 for the year ended December 31, 2020 as our share of loss from our minority interest calculated under the equity method was limited to the reduction of the net book value of the investment to zero as of March 31, 2020.

*Other Income.* Other income increased by approximately \$74,000 from zero for the year ended December 31, 2020. The increase was primarily related to income from a sublease agreement we entered into with a tenant on March 1, 2021 to sublet a small portion of our Los Gatos facility.

### **Liquidity, Capital Resources and Going Concern**

As of December 31, 2021 we had approximately \$20.0 million of cash, cash equivalents and restricted cash and had an accumulated deficit of approximately \$165.3 million.

In May 2020, we received a loan in the form of a note, from Silicon Valley Bank (“SVB”) in the aggregate amount of approximately \$715,000 (the “Loan”), pursuant to the Paycheck Protection Program (the “PPP”). The PPP, established as part of the Coronavirus Aid, Relief and Economic Security Act (“CARES Act”), provided for loans to qualifying businesses for amounts up to 2.5 times of the average monthly payroll expenses of the qualifying business. In May 2021 we received notification that the PPP Loan was ultimately forgiven and we were legally released from being the Loan’s primary obligor. The extinguishment of the liability was recognized in our consolidated statement of operations as an extinguishment of debt gain.

In October 2020, we entered into a Securities Purchase Agreement (the “October 2020 Purchase Agreement”) with certain institutional investors (the “Purchasers”), pursuant to which we agreed to offer, issue and sell to the Purchasers, (i) in a registered direct offering, an aggregate of 1,134,470 shares (the “Shares”) of common stock, par value \$0.0001 per share (“Common Stock”) and (ii) in a concurrent private placement, Series A warrants (the “Series A Warrants”) and Series B warrants (the “Series B Warrants” and collectively, with the Series A Warrants, the “Warrants”) to purchase up to an aggregate 567,234 shares (the “Warrant Shares”) of Common Stock, for aggregate gross proceeds to us of approximately \$8.5 million, before deducting estimated offering expenses payable by us. We agreed to pay Arcadia Securities, LLC a fee equal to 3.5% of the aggregate purchase price of the shares of its common stock sold in the offering to certain of the investors. In addition, we agreed to pay Cantor Fitzgerald & Co. a fee equal to 3.5% of the aggregate purchase price of the shares of its common stock sold in the offering.

In March 2021, we entered into a Securities Purchase Agreement with certain institutional and individual investors, pursuant to which we agreed to offer, issue and sell to these investors, in a registered direct offering, an aggregate of 1,037,405 shares of our common stock for aggregate gross proceeds to us of approximately \$7.0 million, and after deducting commissions and offering costs, net proceeds were approximately \$6.4 million.

As a result of the March 2021 registered direct offering price per share being less than the October 2020 registered direct offering price per share, we were obligated to issue an additional 124,789 shares of unregistered common stock to the investors in our October 2020 registered direct offering pursuant to the anti-dilutive provisions of the October 2020 Securities Purchase Agreement. In March 2021, we issued 124,789 shares to our common stockholders, who purchased in October 2020, with a fair value of approximately \$986,000 which we recorded as a credit to additional paid-in capital, and since we have an accumulated deficit, the corresponding debit to additional paid-in capital, resulting in no dollar impact within our consolidated statement of changes in stockholders’ equity (deficit).

On August 2, 2021, we entered into a Securities Purchase Agreement with an institutional investor, pursuant to which we agreed to offer, issue and sell to this investor, in a registered direct offering, 1,300,000 shares of our common stock, pre-funded warrants to purchase up to an aggregate of 3,647,556 shares of our common stock (the “Pre-Funded Warrants”), and warrants to purchase up to 2,473,778 shares of our common stock (the “Warrants”). The combined purchase price of each share of common stock and accompanying Warrants is \$5.053 per share. The combined purchase price of each Pre-Funded Warrant and accompanying Warrant is \$5.052 (equal to the combined purchase price per share of common stock and accompanying Warrant, minus \$0.001). We received gross proceeds of approximately \$25.0 million, and after deducting the placement agent fees and expenses and our estimated offering expenses, net proceeds were approximately \$22.6 million.



As a result of the August 2021 registered direct offering price per share being less than the October 2020 and March 2021 registered direct offerings price per share, we were obligated to issue an additional 634,600 shares of unregistered common stock to the investors in our October 2020 and March 2021 registered direct offerings pursuant to the anti-dilutive provisions of the October 2020 and March 2021 Securities Purchase Agreements. In August 2021, we issued 634,600 shares to our common stockholders, who purchased in October 2020 and March 2021, with a fair value of approximately \$3.1 million which we recorded as a credit to additional paid-in capital, and since we have an accumulated deficit, the corresponding debit to additional paid-in capital, resulting in no dollar impact within our consolidated statement of changes in stockholders' equity (deficit).

The Company entered into a Note Purchase Agreement with Streeterville Capital, LLC (the "Lender"), pursuant to which we issued to the Lender a secured promissory note (the "Note") in the aggregate principal amount of \$5,250,000. Closing occurred on November 23, 2021 (the "Issuance Date"). The Note carries an original issue discount of \$250,000. The Note bears interest at the rate of 6% per annum and matures on November 23, 2023. Net proceeds after deducting the discount fee were \$5,000,000.

The Company obtained financing for certain Director & Officer liability insurance policy premiums from First Insurance Funding. The total premiums, taxes and fees financed is approximately \$1,645,000 with an annual percentage interest rate of 3.67%. At December 31, 2021 the Company recognized approximately \$696,000 as insurance financing note payable in its consolidated balance sheet.

We have had recurring losses from operations since inception and negative cash flows from operating activities during the years ended December 31, 2021 and 2020. We anticipate that we will continue to generate operating losses and use cash in operations through the foreseeable future. Management plans to finance operations through equity or debt financings or other capital sources, including potential collaborations or other strategic transactions. There can be no assurances that, in the event that we require additional financing, such financing will be available on terms which are favorable to us, or at all. If we are unable to raise additional funding to meet our working capital needs in the future, we will be forced to delay or reduce the scope of our research programs and/or limit or cease our operations. We believe that our current available cash and cash equivalents, along with the additional cash received in February 2022 from additional debt funding, will not be sufficient to fund our planned expenditures and meet our obligations for at least the one-year period following our consolidated financial statements issuance date. There is substantial doubt about our ability to continue as a going concern unless we are able to successfully raise additional capital.

### **Cash Flows**

Our net cash flow from operating, investing and financing activities for the periods below were as follows (in thousands):

	<b>December 31,</b>	
	<b>2021</b>	<b>2020</b>
Net cash provided by (used in):		
Operating activities	\$ (22,936)	\$ (20,476)
Investing activities	(530)	(367)
Financing activities	34,720	8,678
Net increase (decrease) in cash and cash equivalents	<u>\$ 11,254</u>	<u>\$ (12,165)</u>

#### *Cash Flows from Operating Activities.*

Net cash used in operating activities was approximately \$22.9 million for the year ended December 31, 2021, which was primarily due to our net loss of approximately \$42.2 million, offset by an increase of approximately \$5.3 million in accrued liabilities and other, an increase of approximately \$2.6 million in accounts payables, an increase of approximately \$2.3 million in deferred revenue and other receivables, an increase of approximately \$6.4 million related to issuance of common stock for licensing activities, and non-cash charges of approximately \$2.3 million related to stock-based compensation and approximately \$435,000 in depreciation and amortization.

Net cash used in operating activities was approximately \$20.5 million for the year ended December 31, 2020, which was primarily due to our net loss of approximately \$22.3 million, an increase of approximately \$488,000 related to capitalized contract costs, resulting from the SAMR License Agreement entered into in 2019, a decrease of approximately \$756,000 in accrued liabilities and other, a decrease of approximately \$83,000 in accounts payables, and an increase of approximately \$144,000 in other receivables. The

cash used in operating activities was partially offset by a decrease of approximately \$808,000 in prepaid expenses and a decrease of approximately \$46,000 in other assets, and the non-cash charges of approximately \$2.1 million related to stock-based compensation and approximately \$337,000 in depreciation and amortization.

*Cash Flows from Investing Activities.*

Cash used in investing activities of approximately \$530,000 during the year ended December 31, 2021, was due to improvements to our new leased facility and the purchase of lab equipment.

Cash used in investing activities of approximately \$367,000 during the year ended December 31, 2020, was due to the purchase of equipment, primarily for diagnostic use in clinical trials, and improvements to our new leased facility in December 2020.

*Cash Flows from Financing Activities.*

Net cash provided by financing activities of approximately \$34.7 million during the year ended December 31, 2021 was due to net proceeds received from issuance of common stock and common stock warrants of approximately \$29.7 million, and proceeds received from notes payable of approximately \$5.0 million.

Net cash provided by financing activities of approximately \$8.7 million during the year ended December 31, 2020 was due to net proceeds received from a registered direct offering of our common stock and a concurrent private placement of common stock warrants of approximately \$7.9 million, proceeds received from the PPP Loan of approximately \$715,000, net proceeds received from our ATM Agreement of approximately \$62,000, and net proceeds received from stock option exercises of approximately \$14,000.

***Future Funding Requirements***

To date, we have generated revenue from grants and contract services performed and funding from the issuance of convertible preferred stock and common stock sales. We do not know when, or if, we will generate any revenue from our development stage therapeutic programs. We do not expect to generate any revenue from sales of our therapeutic candidates unless and until we obtain regulatory approval. At the same time, we expect our expenses to increase in connection with our ongoing development activities, particularly as we continue the research, development and clinical trials of, and seek regulatory approval for, our therapeutic candidates. We expect to incur additional costs associated with operating as a public Company. In addition, subject to obtaining regulatory approval of any of our therapeutic candidates, we expect to incur significant commercialization expenses for product sales, marketing, manufacturing and distribution. We anticipate that we will need additional funding in connection with our continuing operations.

Our future funding requirements will depend on many factors, including:

- the progress, costs, results and timing of our clinical trials;
- FDA acceptance, if any, of our therapies for infectious diseases and for other potential indications;
- the outcome, costs and timing of seeking and obtaining FDA and any other regulatory approvals;
- the number and characteristics of product candidates that we pursue, including our product candidates in preclinical development;
- the ability of our product candidates to progress through clinical development successfully;
- our need to expand our research and development activities;
- the costs of acquiring, licensing or investing in businesses, products, product candidates and technologies;

- our ability to maintain, expand and defend the scope of our intellectual property portfolio, including the amount and timing of any payments we may be required to make, or that we may receive, in connection with the licensing, filing, prosecution, defense and enforcement of any patents or other intellectual property rights;
- the effect of the COVID-19 pandemic on our business and operations;
- our need and ability to hire additional management and scientific, medical and administrative personnel;
- the effect of competing technological and market developments; and
- our need to implement additional internal systems and infrastructure, including financial and reporting systems.

Until such time that we can generate meaningful revenue from the sales of approved therapies and products, if ever, we expect to finance our operating activities through public or private equity or debt financings, government or other third-party funding, and other collaborations, strategic alliances and licensing arrangements or a combination of these approaches. To the extent that we raise additional capital through the sale of equity or convertible debt securities, the ownership interests of our common stockholders will be diluted, and the terms of these securities may include liquidation or other preferences that adversely affect the rights of our common stockholders. Debt financing, if available, may involve agreements that include conversion discounts or covenants limiting or restricting our ability to take specific actions, such as incurring additional debt, making capital expenditures or declaring dividends. If we raise additional funds through government or other third-party funding, marketing and distribution arrangements or other collaborations, or strategic alliances or licensing arrangements with third parties, we may have to relinquish valuable rights to our technologies, future revenue streams, research programs or product candidates or to grant licenses on terms that may not be favorable to us.

#### **Off-Balance Sheet Arrangements**

During the periods presented we did not have, nor do we currently have, any off-balance sheet arrangements as defined under the rules of the SEC.

#### **JOBS Act Accounting Election**

The JOBS Act permits an “emerging growth Company” such as us to take advantage of an extended transition period to comply with new or revised accounting standards applicable to public companies. We are choosing to take advantage of this provision and, as a result, we will adopt the extended transition period available under the JOBS Act until the earlier of the date we (i) are no longer an emerging growth Company or (ii) affirmatively and irrevocably opt out of the extended transition period provided under the JOBS Act.

#### **Recent Accounting Pronouncements**

Information regarding recent accounting pronouncements applicable to us is included in the notes to our consolidated financial statements included elsewhere in this Annual Report on Form 10-K.

#### **Item 7A. Quantitative and Qualitative Disclosures about Market Risk**

Not applicable.

#### **Item 8. Financial Statements and Supplementary Data**

The financial statements required to be filed pursuant to this Item 8 are appended to this Annual Report. An index of those financial statements is found in Item 15.

#### **Item 9. Changes in and Disagreements with Accountants on Accounting and Financial Disclosure**

None.

## **Item 9A. Controls and Procedures**

### ***Evaluation of Disclosure Controls and Procedures***

Under the supervision and with the participation of our management, including our Chief Executive Officer and Chief Financial Officer, we conducted an evaluation of the effectiveness of the design and operation of our disclosure controls and procedures, as defined in Rules 13a-15(e) and 15d-15(e) under the Exchange Act, as of the end of the period covered by this report.

In designing and evaluating our disclosure controls and procedures, management recognizes that any disclosure controls and procedures, no matter how well designed and operated, can provide only reasonable assurance of achieving the desired control objectives. In addition, the design of disclosure controls and procedures must reflect the fact that there are resource constraints and that management is required to apply its judgment in evaluating the benefits of possible controls and procedures relative to their costs.

Based on that evaluation, the Chief Executive Officer and Chief Financial Officer concluded that the Company's disclosure controls and procedures were not effective as of December 31, 2021 due to the material weaknesses in our internal controls over financial reporting described below. Notwithstanding these material weaknesses, management has concluded that our consolidated financial statements included in this Annual Report on Form 10-K are fairly stated in all material respects in accordance with GAAP for each of the periods presented therein.

### **Management's Annual Report on Internal Controls Over Financial Reporting**

Under the supervision and with the participation of our management, including our Chief Executive Officer and Chief Financial Officer, we conducted an evaluation of the effectiveness of our internal control over financial reporting based on criteria established in "Internal Control—Integrated Framework (2013)" issued by the Committee of Sponsoring Organizations of the Treadway Commission (COSO).

In connection with the audit of our consolidated financial statements for the year ended December 31, 2021, our management with the participation of our Chief Executive Officer and Chief Financial Officer concluded that our internal control over financial reporting was ineffective due to a material weakness in our internal controls resulting from our finance department not being able to process and account for complex, non-routine transactions in a timely manner. While we have designed and implemented, or expect to implement, measures that we believe address or will address this control weakness, we continue to develop our internal controls, processes and reporting systems by, among other things, hiring qualified personnel with expertise to perform specific functions, and designing and implementing improved processes and internal controls, including ongoing senior management review and audit committee oversight. We plan to remediate the identified material weakness by hiring financial consultants and we expect to hire additional senior accounting staff to complete the remediation by the end of 2022.

We are taking steps to remediate the material weaknesses in our internal controls over financial reporting. Further, we plan to enhance our processes to identify and appropriately apply applicable accounting requirements to better evaluate and understand the nuances of the complex accounting standards that apply to our financial statements. Our plans at this time include providing enhanced access to accounting literature, research materials and documents and increased communication among our personnel and third-party professionals with whom we consult regarding complex accounting applications. The elements of our remediation plan can only be accomplished over time, and we can offer no assurance that these initiatives will ultimately have the intended effects.

The conclusion of the Company's Chief Executive Officer and Chief Financial Officer is based on the recognition that there are inherent limitations in all systems of internal control over financial reporting. Because of its inherent limitations, internal control over financial reporting may not prevent or detect misstatements, errors or fraud. Also, projections of any evaluation of effectiveness to future periods are subject to the risk that controls may become inadequate because of changes in conditions, or that the degree of compliance with the policies or procedures may deteriorate.

This Annual Report on Form 10-K does not include an attestation report of our independent registered public accounting firm regarding internal control over financial reporting. We were not required to have, nor have we, engaged our independent registered public accounting firm to perform an audit of internal control over financial reporting pursuant to SEC rules that permit us to provide only management's report in this Annual Report on Form 10-K.

### **Changes in Internal Control over Financial Reporting**

In connection with the audit of our financial statements for the years ended December 31, 2021, we had a material weakness in our internal controls resulting from turnover in our Accounting department. Our efforts to remediate the identified material weakness included the hiring of a replacement Vice President of Finance in November 2021 as well as hiring two additional support staff in the first quarter of 2022. With the hiring of these individuals we have begun to rebuild and strengthen our accounting team and expect to complete the remediation of this material weakness during 2022.

No other change in our internal control over financial reporting (as defined in Rules 13a-15(f) and 15d-15(f) under the Exchange Act) occurred during the quarter ended December 31, 2021 that has materially affected, or is reasonably likely to materially affect, our internal control over financial reporting other than as described above.

### **Item 9B. Other Information**

None.

## **PART III**

### **Item 10. Directors, Executive Officers and Corporate Governance**

The information required by this Item is incorporated herein by reference to the information that will be contained in our definitive proxy statement related to the 2022 Annual Meeting of Stockholders (the "Proxy Statement"), which we intend to file with the SEC within 120 days of the end of our fiscal year pursuant to General Instruction G(3) of Form 10-K.

### **Item 11. Executive Compensation**

The information required by this Item is incorporated herein by reference to the information that will be contained in our Proxy Statement, which we intend to file with the SEC within 120 days of the end of our fiscal year pursuant to General Instruction G(3) of Form 10-K.

### **Item 12. Security Ownership of Certain Beneficial Owners and Management and Related Stockholder Matters**

The information required by this Item is incorporated herein by reference to the information that will be contained in our Proxy Statement, which we intend to file with SEC within 120 days of the end of our fiscal year pursuant to General Instruction G(3) of Form 10-K.

### **Item 13. Certain Relationships and Related Transactions, and Director Independence**

The information required by this Item is incorporated herein by reference to the information that will be contained in our Proxy Statement, which we intend to file with the SEC within 120 days of the end of our fiscal year pursuant to General Instruction G(3) of Form 10-K.

### **Item 14. Principal Accounting Fees and Services**

The information required by this Item is incorporated herein by reference to the information that will be contained in our Proxy Statement which we intend to file with the SEC within 120 days of the end of our fiscal year pursuant to General Instruction G(3) of Form 10-K.

**PART IV**

**Item 15. Exhibits and Financial Statement Schedules**

(a) The following documents are filed as part of this report:

(1) Financial Statements:

<a href="#">Report of Independent Registered Public Accounting Firm</a>	F-2
<a href="#">Consolidated Balance Sheets</a>	F-3
<a href="#">Consolidated Statements of Operations</a>	F-4
<a href="#">Consolidated Statements of Changes in Stockholders' Equity (Deficit)</a>	F-5
<a href="#">Consolidated Statements of Cash Flows</a>	F-6
<a href="#">Notes to Consolidated Financial Statements</a>	F-7

(2) Financial Statement Schedules:

All financial statement schedules have been omitted because they are not applicable, not required or the information required is shown in the consolidated financial statements or the notes thereto.

(3) Exhibits.

<u>Exhibit No.</u>	<u>Description</u>
1.1	<a href="#">At-the-Market Sales Agreement dated January 19, 2022 by and between the Registrant and Virtu Americas LLC (filed with the Registrant's Current Report on Form 8-K on January 19, 2022 and incorporated herein by reference).</a>
3.1	<a href="#">Certificate of Incorporation of the Registrant, as amended (filed with the Registrant's Amendment No. 2 to its Registration Statement on Form S-1 (file no. 333-226232), filed with the SEC on August 8, 2018 and incorporated herein by reference).</a>
3.2	<a href="#">Amended and Restated Certificate of Incorporation of the Registrant (filed with the Registrant's Amendment No. 1 to its Registration Statement on Form S-1 (file no. 333-226232), filed with the SEC on August 6, 2018 and incorporated herein by reference).</a>
3.3	<a href="#">Amended and Restated Certificate of Designation of Preferences, Rights and Limitations of Series A Convertible Preferred Stock of the Registrant, as amended (filed with the Registrant's Amendment No. 2 to its Registration Statement on Form S-1 (file no. 333-226232), filed with the SEC on August 8, 2018 and incorporated herein by reference).</a>
3.4	<a href="#">Bylaws of the Registrant (filed with the Registrant's Registration Statement on Form S-1 (file no. 333-226232), filed with the SEC on July 18, 2018 and incorporated herein by reference).</a>
3.5	<a href="#">Certificate of Correction to Amended and Restated Certificate of Incorporation (filed with the Registrant's Amendment No. 2 to its Registration Statement on Form S-1 (file no. 333-226232), filed with the SEC on August 8, 2018 and incorporated herein by reference).</a>
4.1	<a href="#">Description of the Registrant's Securities registered pursuant to Section 12 of the Securities Exchange Act of 1934 (filed with the Registrant's Annual Report on Form 10-K on April 8, 2020 and incorporated herein by reference).</a>
10.1@	<a href="#">Aridis Pharmaceuticals, Inc. 2014 Equity Incentive Plan (filed with the Registrant's Registration Statement on Form S-1 (file no. 333-226232), filed with the SEC on July 18, 2018 and incorporated herein by reference).</a>
10.2#	<a href="#">Exclusive and Non-Exclusive Patent License Agreement between the Registrant and the Public Health Service, dated July 11, 2005 (filed with the Registrant's Registration Statement on Form S-1 (file no. 333-226232), filed with the SEC on July 18, 2018 and incorporated herein by reference).</a>
10.3#	<a href="#">License and Option Agreement by and between the Registrant and Brigham Young University, dated July 29, 2005 (filed with the Registrant's Registration Statement on Form S-1 (file no. 333-226232), filed with the SEC on July 18, 2018 and incorporated herein by reference).</a>
10.4#	<a href="#">License Agreement by and between the Registrant and The University of Iowa Research Foundation, dated October 22, 2010 (filed with the Registrant's Registration Statement on Form S-1 (file no. 333-226232), filed with the SEC on July 18, 2018 and incorporated herein by reference).</a>

[Table of Contents](#)

<u>Exhibit No.</u>	<u>Description</u>
10.5#	<a href="#">First Amendment to License Agreement, by and between the Registrant and The University of Iowa Research Foundation, dated January 10, 2017 (filed with the Registrant's Registration Statement on Form S-1 (file no. 333-226232), filed with the SEC on July 18, 2018 and incorporated herein by reference)</a>
10.6#	<a href="#">Exclusive Patent License Agreement by and between the Registrant and The Brigham and Women's Hospital, Inc., dated November 16, 2010 (filed with the Registrant's Registration Statement on Form S-1 (file no. 333-226232), filed with the SEC on July 18, 2018 and incorporated herein by reference)</a>
10.7#	<a href="#">First Amendment to Exclusive Patent License Agreement, by and between the Registrant and The Brigham and Women's Hospital, Inc., dated February 18, 2016 (filed with the Registrant's Registration Statement on Form S-1 (file no. 333-226232), filed with the SEC on July 18, 2018 and incorporated herein by reference)</a>
10.8#	<a href="#">Asset Purchase Agreement between the Registrant and Kenta Biotech Ltd., dated May 10, 2013 (filed with the Registrant's Registration Statement on Form S-1 (file no. 333-226232), filed with the SEC on July 18, 2018 and incorporated herein by reference)</a>
10.9#	<a href="#">Formulation Development Agreement between the Registrant and PATH Vaccine Solutions, dated June 1, 2007 (filed with the Registrant's Registration Statement on Form S-1 (file no. 333-226232), filed with the SEC on July 18, 2018 and incorporated herein by reference)</a>
10.10#	<a href="#">Agreement between the Registrant and the Cystic Fibrosis Foundation Therapeutics, Inc., dated December 30, 2016 (filed with the Registrant's Registration Statement on Form S-1 (file no. 333-226232), filed with the SEC on July 18, 2018 and incorporated herein by reference)</a>
10.11#	<a href="#">Co-exclusive License Agreement between The University of Chicago and the Registrant, dated June 13, 2017 (filed with the Registrant's Registration Statement on Form S-1 (file no. 333-226232), filed with the SEC on July 18, 2018 and incorporated herein by reference)</a>
10.12#	<a href="#">License Agreement by and between the Registrant and Emergent Product Development Gaithersburg, Inc., dated January 6, 2010 (filed with the Registrant's Registration Statement on Form S-1 (file no. 333-226232), filed with the SEC on July 18, 2018 and incorporated herein by reference)</a>
10.13	<a href="#">Joint Venture Contract in respect of Shenzhen Arimab BioPharmaceutical Co., Ltd., by and between Shenzhen Hepalink Pharmaceutical Group Co. and the Registrant, dated February 11, 2018 (filed with the Registrant's Registration Statement on Form S-1 (file no. 333-226232), filed with the SEC on July 18, 2018 and incorporated herein by reference)</a>
10.14	<a href="#">Technology License and Collaboration Agreement, by and between Shenzhen Arimab BioPharmaceutical Co., Ltd. and the Registrant, dated July 2, 2018 (filed with the Registrant's Registration Statement on Form S-1 (file no. 333-226232), filed with the SEC on July 18, 2018 and incorporated herein by reference)</a>
10.15	<a href="#">License and Option Agreement, by and between Brigham Young University and the Registrant, dated July 29, 2005 (filed with the Registrant's Registration Statement on Form S-1 (file no. 333-226232), filed with the SEC on July 18, 2018 and incorporated herein by reference)</a>
10.16	<a href="#">Amendment to the Joint Venture Contract in respect of Shenzhen Arimab BioPharmaceutical Co., Ltd., by and between Shenzhen Hepalink Pharmaceutical Group Co. and the Company, effective August 6, 2018 (filed with the Registrant's Quarterly Report on Form 10-Q for the quarter ended June 30, 2018 and incorporated herein by reference)</a>
10.17	<a href="#">Amended and Restated Technology License and Collaboration Agreement, by and between Shenzhen Arimab BioPharmaceutical Co., Ltd. and the Company, effective August 6, 2018 (filed with the Registrant's Quarterly Report on Form 10-Q for the quarter ended June 30, 2018 and incorporated herein by reference)</a>
10.18#	<a href="#">Amendment No. 1 to the Agreement between the Registrant and the Cystic Fibrosis Foundation Therapeutics, Inc., effective November 26, 2018 (filed with the Registrant's Annual Report on Form 10-K/A on June 12, 2019 and incorporated herein by reference)</a>
10.19†	<a href="#">Option Agreement for Exclusive Product and Platform Technology License between Aridis Pharmaceuticals, Inc. and Serum International BV, dated July 16, 2019 (filed with the Registrant's Current Report on Form 8-K on July 30, 2019 and on Form 8-K/A on August 12, 2019 and incorporated herein by reference)</a>
10.20	<a href="#">Stock Subscription Agreement between Aridis Pharmaceuticals, Inc. and Serum International BV, dated July 19, 2019 (filed with the Registrant's Current Report on Form 8-K on July 30, 2019 and on Form 8-K/A on August 12, 2019 and incorporated herein by reference)</a>

[Table of Contents](#)

<u>Exhibit No.</u>	<u>Description</u>
10.21†	<a href="#">License, Development and Commercialization Agreement between Aridis Pharmaceuticals Inc. and Serum AMR Products, entered into as of September 27, 2019 (filed with the Registrant's Current Report on Form 8-K on October 2, 2019 and incorporated herein by reference)</a>
10.22	<a href="#">Aridis Pharmaceuticals, Inc. 2014 Amended and Restated 2014 Equity Incentive Plan (filed with the Registrant's Proxy Statement as Appendix A on April 17, 2020 and incorporated herein by reference)</a>
10.23	<a href="#">Promissory Note between the Registrant and Silicon Valley Bank dated May 1, 2020 (filed with the Registrant's Current Report on Form 8-K on May 5, 2020 and incorporated herein by reference)</a>
10.24	<a href="#">Form of Securities Purchase Agreement, dated October 13, 2020, by and between Aridis Pharmaceuticals, Inc. and the Purchasers (filed with the Registrant's Current Report on Form 8-K on October 14, 2020 and incorporated herein by reference)</a>
10.25	<a href="#">Form of Series A Warrant (filed with the Registrant's Current Report on Form 8-K on October 14, 2020 and incorporated herein by reference)</a>
10.26	<a href="#">Form of Series B Warrant (filed with the Registrant's Current Report on Form 8-K on October 14, 2020 and incorporated herein by reference)</a>
10.27	<a href="#">Office Lease dated October 14, 2020 by and between Aridis Pharmaceuticals, Inc. and Boccardo Corporation (filed with the Registrant's Current Report on Form 8-K on October 20, 2020 and incorporated herein by reference)</a>
10.28†	<a href="#">Exclusive License Agreement dated September 10, 2020 by and between Aridis Pharmaceuticals, Inc. and UAB Research Foundation (filed with the Registrant's Quarterly Report on Form 10-Q on November 23, 2020 and incorporated herein by reference)</a>
10.29	<a href="#">Form of Securities Purchase Agreement dated March 15, 2021 by and between Aridis Pharmaceuticals, Inc. and the Purchasers (filed with the Registrant's Current Report on Form 8-K on March 15, 2021 and incorporated herein by reference)</a>
10.30†	<a href="#">License Agreement between MedImmune Limited and Aridis Pharmaceuticals, Inc. dated as of July 12, 2021 (filed with the Registrant's Current Report on Form 8-K on July 19, 2021 and incorporated herein by reference)</a>
10.31	<a href="#">Form of Common Stock Purchase Warrant (filed with the Registrant's Current Report on Form 8-K on August 4, 2021 and incorporated herein by reference)</a>
10.32	<a href="#">Form of Securities Purchase Agreement (filed with the Registrant's Current Report on Form 8-K on August 4, 2021 and incorporated herein by reference)</a>
10.33	<a href="#">Form of Secured Promissory Note (filed with the Registrant's Current Report on Form 8-K on November 30, 2021 and incorporated herein by reference)</a>
10.34	<a href="#">Note Purchase Agreement dated as of November 23, 2021 (filed with the Registrant's Current Report on Form 8-K on November 30, 2021 and incorporated herein by reference)</a>
10.35	<a href="#">Security Agreement dated as of November 23, 2021 (filed with the Registrant's Current Report on Form 8-K on November 30, 2021 and incorporated herein by reference)</a>
21.1*	<a href="#">Subsidiaries of the Registrant</a>
23.1*	<a href="#">Consent of Independent Registered Public Accounting Firm</a>
24.1*	<a href="#">Power of Attorney (included on signature page)</a>
31.1*	<a href="#">Certification of Principal Executive Officer Pursuant to Rules 13a-14(a) and 15d-14(a) under the Securities Exchange Act of 1934, as Adopted Pursuant to Section 302 of the Sarbanes-Oxley Act of 2002</a>
31.2*	<a href="#">Certification of Principal Financial Officer Pursuant to Rules 13a-14(a) and 15d-14(a) under the Securities Exchange Act of 1934, as Adopted Pursuant to Section 302 of the Sarbanes-Oxley Act of 2002</a>
32.1*	<a href="#">Certification of Principal Executive Officer Pursuant to 18 U.S.C. Section 1350, as Adopted Pursuant to Section 906 of the Sarbanes-Oxley Act of 2002</a>
32.2*	<a href="#">Certification of Principal Financial Officer Pursuant to 18 U.S.C. Section 1350, as Adopted Pursuant to Section 906 of the Sarbanes-Oxley Act of 2002</a>
101.INS*	XBRL Instance Document
101.SCH*	XBRL Taxonomy Extension Schema Document



[Table of Contents](#)

<u>Exhibit No.</u>	<u>Description</u>
101.CAL*	XBRL Taxonomy Extension Calculation Linkbase Document
101.DEF*	XBRL Taxonomy Extension Definition Linkbase Document
101.LAB*	XBRL Taxonomy Extension Label Linkbase Document
101.PRE*	XBRL Taxonomy Extension Presentation Linkbase Document
104*	Cover Page Interactive Data File (embedded within the Inline XBRL document and included in Exhibit 101).

\* Filed herewith

@ Indicates a management contract or any compensatory plan, contract or arrangement

# Confidential treatment has been granted for portions omitted from this exhibit (indicated by asterisks) and those portions have been separately filed with the Securities and Exchange Commission.

† Pursuant to Item 601(b)(10) of Regulation S-K, certain confidential portions of this exhibit were omitted by means of making such portions with an asterisk because the identified confidential portions (i) are not material and (ii) would be competitively harmful if publicly disclosed.

**Item 16. Form 10-K Summary**

Not applicable

SIGNATURES

Pursuant to the requirements of the Securities Exchange Act of 1934, the Registrant has duly caused this report to be signed on its behalf by the undersigned thereunto duly authorized.

Aridis Pharmaceuticals, Inc.

Dated: April 13, 2022

By: \_\_\_\_\_  
/s/ VU TRUONG  
Vu Truong  
*Chief Executive Officer, Chief Scientific Officer and  
Director (Principal Executive Officer)*

By: \_\_\_\_\_  
/s/ FRED KURLAND  
Fred Kurland  
*Chief Financial Officer  
(Principal Accounting Officer)*

## POWER OF ATTORNEY

KNOW ALL PERSON BY THESE PRESENTS, that each person whose signature appears below constitutes and appoints Vu Truong, as his or her true and lawful attorney-in-fact and agent, with full power of substitution and resubstitution, for him or her and in his or her name, place and stead, in any and all capacities, to sign any and all amendments to this Annual Report on Form 10-K and to file the same, with all exhibits thereto and other documents in connection therewith, with the Securities and Exchange Commission, granting unto said attorney-in-fact and agent full power and authority to do and perform each and every act and thing requisite and necessary to be done in connection therewith, as fully to all intents and purposes as he or she might or could do in person, hereby ratify and confirming all that said attorney-in-fact and agent or his substitute, may lawfully do or cause to be done by virtue hereof.

Pursuant to the requirements of the Securities Exchange Act of 1934, this report has been signed below by the following persons on behalf of the Registrant and in the capacities and on the dates indicated.

<u>Signature</u>	<u>Title</u>	<u>Date</u>
<u>/s/ ERIC PATZER</u> Eric Patzer	Executive Chairman and Director	April 13, 2022
<u>/s/ VU TRUONG</u> Vu Truong	Chief Executive Officer, Chief Scientific Officer and Director (Principal Executive Officer)	April 13, 2022
<u>/s/ FRED KURLAND</u> Fred Kurland	Chief Financial Officer (Principal Financial Officer and Principal Accounting Officer)	April 13, 2022
<u>/s/ ROBERT R. RUFFOLO</u> Robert R. Ruffolo	Director	April 13, 2022
<u>/s/ CRAIG GIBBS</u> Craig Gibbs	Director	April 13, 2022
<u>/s/ JOHN HAMILTON</u> John Hamilton	Director	April 13, 2022
<u>/s/ SUSAN WINDHAM-BANNISTER</u> Susan Windham-Bannister	Director	April 13, 2022

**CONSOLIDATED FINANCIAL STATEMENTS**

**ARIDIS PHARMACEUTICALS, INC.  
Index to Consolidated Financial Statements**

	<u>Page(s)</u>
<a href="#">Report of Independent Registered Public Accounting Firm</a> (PCAOB Firm ID 199)	F-2
<a href="#">Consolidated Balance Sheets</a>	F-3
<a href="#">Consolidated Statements of Operations</a>	F-4
<a href="#">Consolidated Statements of Changes in Stockholders' Equity (Deficit)</a>	F-5
<a href="#">Consolidated Statements of Cash Flows</a>	F-6
<a href="#">Notes to Consolidated Financial Statements</a>	F-7

## REPORT OF INDEPENDENT REGISTERED PUBLIC ACCOUNTING FIRM

To the Board of Directors and Stockholders of **Aridis Pharmaceuticals, Inc.**

### Opinion on the Consolidated Financial Statements

We have audited the accompanying consolidated balance sheets of Aridis Pharmaceuticals, Inc. (“Company”) as of December 31, 2021 and 2020, and the related consolidated statements of operations, changes in stockholders’ equity (deficit), and cash flows for each of the two years in the period ended December 31, 2021, and the related notes (collectively referred to as the “financial statements”). In our opinion, the financial statements present fairly, in all material respects, the financial position of the Company as of December 31, 2021 and 2020, and the results of their operations and their cash flows for each of the two years in the period ended December 31, 2021, in conformity with accounting principles generally accepted in the United States of America.

### Going Concern Uncertainty

The accompanying financial statements have been prepared assuming that the Company will continue as a going concern. As discussed in Note 1 to the financial statements, the Company expects to continue to incur negative cash flows from operations with limited sources of revenue and is therefore dependent on cash on hand and additional financing to fund operations. These conditions raise substantial doubt about the Company’s ability to continue as a going concern. Management’s plans regarding these matters are also described in Note 1. The financial statements do not include any adjustments to reflect the possible future effects on the recoverability and classification of assets or the amounts and classification of liabilities that might result from the outcome of this uncertainty.

### Basis for Opinion

These financial statements are the responsibility of the Company’s management. Our responsibility is to express an opinion on the Company’s financial statements based on our audits. We are a public accounting firm registered with the Public Company Accounting Oversight Board (United States) (“PCAOB”) and are required to be independent with respect to the Company in accordance with the U.S. federal securities laws and the applicable rules and regulations of the Securities and Exchange Commission and the PCAOB.

We conducted our audits in accordance with the standards of the PCAOB. Those standards require that we plan and perform the audits to obtain reasonable assurance about whether the financial statements are free of material misstatement, whether due to error or fraud. The Company is not required to have, nor were we engaged to perform, an audit of its internal control over financial reporting. As part of our audits we are required to obtain an understanding of internal control over financial reporting but not for the purpose of expressing an opinion on the effectiveness of the Company’s internal control over financial reporting. Accordingly, we express no such opinion.

Our audits included performing procedures to assess the risks of material misstatement of the financial statements, whether due to error or fraud, and performing procedures that respond to those risks. Such procedures included examining, on a test basis, evidence regarding the amounts and disclosures in the financial statements. Our audits also included evaluating the accounting principles used and significant estimates made by management, as well as evaluating the overall presentation of the financial statements. We believe that our audits provide a reasonable basis for our opinion.

We have served as the Company’s auditor since 2014.

/s/ Mayer Hoffman McCann P.C.

San Diego, California  
April 13, 2022

**Aridis Pharmaceuticals, Inc.****Consolidated Balance Sheets****(In thousands, except share and per share amounts)**

	<b>December 31,</b>	
	<b>2021</b>	<b>2020</b>
<b>Assets</b>		
Current assets:		
Cash and cash equivalents	\$ 18,098	\$ 8,232
Restricted cash	1,388	—
Other receivables	237	368
Contract costs	1,967	1,973
Prepaid asset	2,700	2,182
Total current assets	<u>24,390</u>	<u>12,755</u>
Property and equipment, net	1,357	1,258
Intangible assets, net	22	27
Restricted cash, non-current	500	500
Contract costs, non-current	96	90
Other assets	431	487
Total assets	<u>\$ 26,796</u>	<u>\$ 15,117</u>
<b>Liabilities and Stockholders' Equity (Deficit)</b>		
Current liabilities:		
Accounts payable	\$ 5,240	\$ 1,886
Accrued liabilities	6,464	1,330
Deferred revenue	20,838	18,748
Note payable	696	439
Other liabilities	110	37
Total current liabilities	<u>33,348</u>	<u>22,440</u>
Deferred revenue, non-current	913	854
Note payable, non-current	5,282	276
Other liabilities	363	228
Total liabilities	<u>39,906</u>	<u>23,798</u>
Commitments and contingencies (Note 13)		
Stockholders' equity (deficit):		
Preferred stock (par value \$0.0001; 60,000,000 shares authorized; zero shares issued and outstanding as of December 31, 2021 and 2020, respectively)	—	—
Common stock (par value \$0.0001; 100,000,000 shares authorized; shares issued and outstanding: 17,701,592 and 10,065,727 as of December 31, 2021 and 2020, respectively)	2	1
Additional paid-in capital	152,183	114,420
Accumulated deficit	(165,295)	(123,102)
Total stockholders' equity (deficit)	<u>(13,110)</u>	<u>(8,681)</u>
Total liabilities and stockholders' equity (deficit)	<u>\$ 26,796</u>	<u>\$ 15,117</u>

See accompanying notes to the consolidated financial statements.

**Aridis Pharmaceuticals, Inc.**  
**Consolidated Statements of Operations**  
**(In thousands, except share and per share amounts)**

	Year Ended December 31,	
	2021	2020
Revenue:		
Grant revenue	\$ 1,535	\$ 1,000
Operating expenses:		
Research and development	36,936	16,956
General and administrative	7,310	6,445
Total operating expenses	44,246	23,401
Loss from operations	(42,711)	(22,401)
Other (expense) income :		
Interest (expense) income, net	(245)	77
Other income	74	—
Gain on extinguishment of Paycheck Protection Program loan	722	—
Change in fair value of note payable	(33)	—
Share of loss from equity method investment	—	(9)
Net loss	\$ (42,193)	\$ (22,333)
Deemed dividends	(4,127)	—
Net loss available to common stockholders	\$ (46,320)	\$ (22,333)
Weighted-average common shares outstanding used in computing net loss per share available to common stockholders, basic and diluted	12,291,600	9,168,744
Net loss per share, basic and diluted	\$ (3.77)	\$ (2.44)

See accompanying notes to the consolidated financial statements.

**Aridis Pharmaceuticals, Inc.**

**Consolidated Statements of Changes in Stockholders' Equity (Deficit)**

**(In thousands, except share amounts)**

	Common Stock		Additional Paid-In Capital	Accumulated Deficit	Total Stockholders' Equity (Deficit)
	Shares	Dollars			
<b>Balances as of December 31, 2019</b>	8,918,461	\$ 1	\$ 104,404	\$ (100,769)	\$ 3,636
Issuance of common stock in private placement, net of issuance costs	1,134,470	—	5,807	—	5,807
Issuance of common stock in ATM offering, net of issuance costs	—	—	2,005	—	2,005
Issuance of common stock in ATM offering, net of issuance costs	7,883	—	62	—	62
Exercise of stock options	4,913	—	14	—	14
Stock-based compensation	—	—	2,128	—	2,128
Net loss	—	—	—	(22,333)	(22,333)
<b>Balances as of December 31, 2020</b>	10,065,727	\$ 1	\$ 114,420	\$ (123,102)	\$ (8,681)
Issuance of common stock in registered direct offering, net of issuance costs	2,337,405	—	29,011	—	29,011
Issuance of common stock in connection with license agreement	884,956	—	6,460	—	6,460
Issuance of common stock for consulting services	5,000	—	33	—	33
Issuance of common stock upon exercise of warrants	3,647,556	1	3	—	4
Deemed dividends	759,389	—	—	—	—
Exercise of stock options	1,559	—	5	—	5
Stock-based compensation	—	—	2,251	—	2,251
Net loss	—	—	—	(42,193)	(42,193)
<b>Balances as of December 31, 2021</b>	<b>17,701,592</b>	<b>\$ 2</b>	<b>\$ 152,183</b>	<b>\$ (165,295)</b>	<b>\$ (13,110)</b>

See accompanying notes to the consolidated financial statements.



**Aridis Pharmaceuticals, Inc.**  
**Consolidated Statements of Cash Flows**  
(In thousands)

	Year Ended December 31,	
	2021	2020
<b>Cash flows from operating activities:</b>		
Net loss	\$ (42,193)	\$ (22,333)
Adjustments to reconcile net loss to net cash used in operating activities:		
Depreciation and amortization	435	337
Stock-based compensation expense	2,251	2,128
Issuance of common stock for licensing activities	6,460	—
Issuance of shares in exchange for consulting services	33	—
Gain on extinguishment of Paycheck Protection Program loan	(722)	—
Non-cash debt issuance expense	250	—
Change in fair value of note payable	33	—
Share of loss from equity method investment	—	9
Changes in operating assets and liabilities:		
Other receivables	131	(144)
Prepaid asset	178	808
Contract costs	—	(488)
Other assets	56	46
Accounts payable	2,654	(83)
Accrued liabilities and other liabilities	5,349	(756)
Deferred revenue	2,149	—
Net cash used in operating activities	<u>(22,936)</u>	<u>(20,476)</u>
<b>Cash flows from investing activities:</b>		
Purchase of property and equipment	(530)	(367)
Net cash used in investing activities	<u>(530)</u>	<u>(367)</u>
<b>Cash flows from financing activities:</b>		
Proceeds from note payable	5,000	715
Proceeds from issuance of common stock and warrants, net	29,715	7,949
Proceeds from stock option exercises	5	14
Net cash provided by financing activities	<u>34,720</u>	<u>8,678</u>
Net increase (decrease) in cash, cash equivalents and restricted cash	<u>11,254</u>	<u>(12,165)</u>
<b>Cash, cash equivalents and restricted cash at:</b>		
Beginning of period	8,732	20,897
End of period	<u>\$ 19,986</u>	<u>\$ 8,732</u>
<b>Supplemental cash flow disclosures:</b>		
Cash paid for taxes	\$ 2	\$ 2
Property and equipment additions	\$ —	\$ 230
<b>Supplemental noncash investing and financing activities:</b>		
Financed insurance premiums, net	\$ 696	\$ —
Deemed dividends	\$ 4,127	\$ —

See accompanying notes to the consolidated financial statements.

**Aridis Pharmaceuticals, Inc.**

**Notes to Consolidated Financial Statements**

**1. Description of Business and Basis of Presentation**

**Organization**

Aridis Pharmaceuticals, Inc. (the “Company” or “we” or “our” or “us”) was established as a California limited liability corporation in 2003. The Company converted to a Delaware C corporation on May 21, 2014. Our principal place of business is in Los Gatos, California. We are a late-stage biopharmaceutical Company focused on developing new breakthrough therapies for infectious diseases and addressing the growing problem of antibiotic resistance. The Company has a deep, diversified portfolio of clinical and pre-clinical stage non-antibiotic anti-infective product candidates that are complimented by a fully human monoclonal antibody discovery platform technology. The Company’s suite of anti-infective monoclonal antibodies offers opportunities to profoundly alter the current trajectory of increasing antibiotic resistance and improve the health outcome of many of the most serious life-threatening infections particularly in hospital settings.

**Basis of Presentation and Consolidation**

The accompanying consolidated financial statements have been prepared in accordance with the United States generally accepted accounting principles, or GAAP. The consolidated financial statements include the accounts of the Company and its two wholly-owned subsidiaries, Aridis Biopharmaceuticals, LLC and Aridis Pharmaceuticals, C.V. All intercompany balances and transactions have been eliminated in consolidation. The Company operates in one segment. Management uses one measurement of profitability and does not segregate its business for internal reporting.

**COVID-19**

The COVID-19 outbreak in the United States has caused business disruption. The extent of the impact of COVID-19 on the Company’s operational and financial performance will depend on certain developments, including the duration and spread of the outbreak, and impact on the Company’s clinical trials, employees and vendors, all of which are uncertain and cannot be predicted. At this point, the extent to which COVID-19 may impact the Company’s financial condition or results of operations is uncertain.

**Going Concern**

The Company had recurring losses from operations since inception and negative cash flows from operating activities during the years ended December 31, 2021 and 2020. Management expects to incur operating losses and negative cash flows from operations in the foreseeable future as the Company continues its product development programs. The forecasted outflow of cash for at least a one-year period from the expected financial statement issuance date, is in excess of the cash available on-hand. In February 2022, the Company received additional gross proceeds of \$5.0 million from debt financing (see Note 14).

The Company’s research and development expenses and resulting cash burn during the year ended December 31, 2021, were largely due to costs associated with the Phase 3 study of AR-301 for the treatment of ventilator associated pneumonia (“VAP”) caused by the *Staphylococcus aureus* (*S. aureus*) bacteria, the Phase 1/2 study of AR-501 for the treatment of chronic lung infections associated with cystic fibrosis, the pre-launch activities associated with the Phase 3 study of AR-320 for the prevention of *S. aureus* VAP, and the preclinical development of AR-712 COVID-19 monoclonal antibodies (mAbs). Current development activities are focused on AR-301, AR-320, AR-501 and AR-712. We expect our expenses to continue in connection with our ongoing development activities, particularly as we continue the research, development and clinical trials of, and seek regulatory approval for, our therapeutic candidates

The on-going COVID-19 pandemic is affecting the United States and global economies. The pandemic has affected the Company and is likely to continue to affect the Company and its third parties, on which the Company relies, by causing disruptions in the clinical trial supplies for the product candidates and the conduct of current and future clinical trials. Additionally, as the duration of the COVID-19 pandemic is difficult to assess or predict, the impact of the COVID-19 pandemic on the global financial markets may reduce our ability to access capital, which could negatively impact the Company’s short-term and long-term liquidity. Additionally, the AR-301 clinical trial currently has sites enrolling in Russia, Ukraine and Belarus. To the extent the conflict between Ukraine and Russia

adversely impacts our ability to enroll patients or complete enrollments in process or adversely impacts the ability of our suppliers to produce and distribute the supplies we need for our AR-301 clinical trial, the timing for completing our AR-301 trial may be adversely impacted. These effects could have a material impact on the Company's liquidity, capital resources, operations and business and those of the third parties on which the Company relies.

The Company plans to fund its cash flow needs through current cash on hand and future debt and equity financings which we may obtain through one or more public or private equity offerings, debt financings, government or other third-party funding, strategic alliances and licensing or collaboration arrangements. If the Company is unable to obtain funding, the Company could be forced to delay, reduce or eliminate its research and development programs or future commercialization efforts, which could adversely affect its future business prospects and its ability to continue as a going concern. The Company believes that its current available cash and cash equivalents, including cash received in February 2022 from debt proceeds, will not be sufficient to fund its planned expenditures and meet the Company's obligations for at least the one-year period following its consolidated financial statement issuance date.

The accompanying consolidated financial statements have been prepared on a going concern basis that contemplates the realization of assets and discharge of liabilities in their normal course of business. There is substantial doubt about the Company's ability to continue as a going concern for one year after the date that these consolidated financial statements are issued. These consolidated financial statements do not include any adjustments that might be necessary from the outcome of this uncertainty.

## **2. Summary of Significant Accounting Policies**

### **Use of Estimates**

The preparation of the consolidated financial statements requires management to make estimates and assumptions that affect the reported amounts of assets and liabilities and disclosure of contingent assets and liabilities as of the date of the consolidated financial statements and the reported amounts of expenses during the reporting period. Such estimates include those related to the evaluation of our ability to continue as a going concern, best estimate of standalone selling price of revenue deliverables, useful life of long-lived assets, classification of deferred revenue, income taxes, assumptions used in the Black-Scholes-Merton ("BSM") model to calculate the fair value of stock-based compensation, deferred tax asset valuation allowances, and preclinical study and clinical trial accruals. Actual results could differ from those estimates.

### **Concentrations**

#### *Credit Risk*

The Company's cash and cash equivalents are maintained at financial institutions in the United States of America. Deposits held by these institutions may exceed the amount of insurance provided on such deposits.

#### *Customer Risk*

For the year ended December 31, 2021, three customers, each individually being 34%, 36% and 30% accounted for 100% of total revenue and for the year ended December 31, 2020, one customer accounted for 100% of total revenue. The customers are located in the United States. As of December 31, 2021 and 2020, there were no accounts receivable.

### **Cash, Cash Equivalents and Restricted Cash**

The Company considers all highly liquid investments purchased with an original maturity of three months or less to be cash equivalents. Cash equivalents consist primarily of checking account and money market fund account balances.

The following table provides a reconciliation of cash, cash equivalents and restricted cash within the consolidated balance sheets which, in aggregate, represent the amount reported in the consolidated statements of cash flows (in thousands):

	December 31,	
	2021	2020
Cash and cash equivalents	\$ 18,098	\$ 8,232
Restricted cash	1,888	500
Total cash, cash equivalents and restricted cash	<u>\$ 19,986</u>	<u>\$ 8,732</u>

Restricted cash consists of deposits for a letter of credit that the Company has provided to secure its obligations under its facility lease and cash received from the Gates Foundation restricted specifically to research associated with the grant. Restricted cash is classified as current when the Company expects to fulfill the obligation within one year or less.

#### **Accounts Receivable and Allowance for Doubtful Accounts**

Accounts receivable are recorded at the invoiced amount and do not bear interest. The Company considers the credit worthiness of its customers but does not require collateral in advance of a sale. The Company evaluates collectability and maintains an allowance for doubtful accounts for estimated losses inherent in its accounts receivable portfolio when necessary. The allowance is based on the Company's best estimate of the amount of losses in the Company's existing accounts receivable, which is based on customer creditworthiness, facts and circumstances specific to outstanding balances, and payment terms. Account balances are charged off against the allowance after all means of collection have been exhausted and the potential for recovery is considered remote. As of December 31, 2021 and 2020, there were no allowances for doubtful accounts.

#### **Operating Leases**

The Company evaluates leases at their inception as either operating or capital leases, and may receive renewal or expansion options, rent holidays, leasehold improvement allowances and other incentives on such lease agreements. The Company recognizes operating lease costs on a straight-line basis over the term of the agreement.

#### **Property and Equipment**

Property and equipment are stated at cost less accumulated depreciation. Depreciation and amortization is computed using the straight-line method over the estimated useful lives of the assets, generally between three and five years for lab equipment and computer equipment and software, and over the shorter of the lease term or useful life for leasehold improvements. Maintenance and repairs are charged to expense as incurred, and costs of improvements are capitalized. When assets are retired or otherwise disposed of, the cost and accumulated depreciation are removed from the consolidated balance sheet and any resulting gain or loss is reflected in the consolidated statement of operations in the period realized.

#### **Intangible Assets**

Intangible assets are recorded at cost and amortized over the estimated useful life of the asset. Intangible assets consist of licenses with various institutions whereby the Company has rights to use intangible property obtained from such institutions.

#### **Impairment of Long-Lived Assets**

The Company reviews long-lived assets for impairment whenever events or changes in circumstances indicate that the carrying amount of an asset may not be recoverable. Recoverability is measured by comparison of the carrying amount to the future undiscounted net cash flows which the assets are expected to generate. If such assets are considered to be impaired, the impairment is measured by the excess of the carrying amount of the assets over fair value less the costs to sell the assets, generally determined using the projected discounted future net cash flows arising from the asset. There have been no such impairments of long-lived assets as of December 31, 2021 and 2020.

## Revenue Recognition

The Company recognizes revenue based on Accounting Standards Codification (“ASC”) 606, *Revenue from Contracts with Customers* (“ASC 606”), which applies to all contracts with customers, except for contracts that are within the scope of other standards, such as leases, insurance, collaboration arrangements and financial instruments. See Note 6 for details of the development and license agreements.

To determine revenue recognition for arrangements that the Company determines are within the scope of ASC 606, the Company performs the following five steps: (i) identify the contract(s) with a customer; (ii) identify the performance obligations in the contract; (iii) determine the transaction price; (iv) allocate the transaction price to the performance obligations in the contract; and (v) recognize revenue at a point in time, or over time, as the entity satisfies performance obligations. The Company only applies the five-step model to contracts when it is probable that it will collect the consideration it is entitled to in exchange for the goods or services it transfers to the customer. At contract inception, once the contract is determined to be within the scope of ASC 606, the Company assesses the goods or services promised within each contract, determines those that are performance obligations, and assesses whether each promised good or service is distinct. The Company then recognizes as revenue the amount of the transaction price that is allocated to the respective performance obligation when (or as) the performance obligation is satisfied.

As part of the accounting for customer arrangements, the Company must use judgment to determine: a) the number of performance obligations based on the determination under step (ii) above; b) the transaction price under step (iii) above; and c) the standalone selling price for each performance obligation identified in the contract for the allocation of the transaction price in step (iv) above. The Company uses judgment to determine whether milestones or other variable consideration should be included in the transaction price.

The transaction price is allocated to each performance obligation on a relative standalone selling price basis. In developing the standalone price for a performance obligation, the Company considers applicable market conditions and relevant entity-specific factors, including factors that were contemplated in negotiating the agreement with the customer and estimated costs. The Company recognizes revenue as or when the performance obligations under the contract are satisfied. The Company receives payments from its customers based on payment schedules established in each contract. The Company records any amounts received prior to satisfying the revenue recognition criteria as deferred revenue on its consolidated balance sheets. Amounts recognized as revenue, but not yet received or invoiced are recorded within other receivables on the consolidated balance sheet. Amounts are recorded as other receivables on the consolidated balance sheet when our right to consideration is unconditional. The Company does not assess whether a contract has a significant financing component if the expectation at contract inception is such that the period between payment by the customer and the transfer of a majority of the promised goods or services to the customer will be one year or less.

## Contract Assets

The incremental costs of obtaining a contract under ASC 606 (i.e. costs that would not have been incurred if the contract had not been obtained) are recognized as an asset in the Company’s consolidated balance sheets if the Company expects to recover them (see Note 6). Capitalized costs will be amortized to the respective expenses using a systematic basis that mirrors the pattern in which the Company transfers control of the goods and service to the customer. At each reporting date, the Company determines whether or not the capitalized costs to obtain a contract are impaired by comparing the carrying amount of the asset to the remaining amount of consideration that the Company received and expects to receive less the costs that relate to providing services under the relevant contract. For the years ended December 31, 2021 and 2020, there was no amortization of the contract assets and there have been no impairments as of December 31, 2021 and 2020.

## Deferred Revenue

Amounts received prior to satisfying the above revenue recognition criteria, or in which the Company has an unconditional right to payment, are recorded as deferred revenue in the Company’s consolidated balance sheets. The Company has estimated the classification between current and noncurrent deferred revenue related to the respective license agreement within its consolidated balance sheets at December 31, 2021 and 2020 (see Note 6).

## **Research and Development**

Research and development costs are expensed to operations as incurred. Our research and development expenses consist primarily of:

- salaries and related overhead expenses, which include stock-based compensation and benefits for personnel in research and development functions;
- fees paid to consultants and contract research organizations, or CROs, including in connection with our preclinical studies and clinical trials and other related clinical trial fees, such as for investigator grants, patient screening, laboratory work, clinical trial material management and statistical compilation and analyses;
- costs related to acquiring and manufacturing clinical trial materials;
- costs related to compliance with regulatory requirements; and
- payments related to licensed products and technologies.

Costs for certain development activities are recognized based on an evaluation of the progress to completion of specific tasks using information and data provided to us by our vendors and clinical sites. Nonrefundable advance payments for goods or services to be received in future periods for use in research and development activities are deferred and capitalized. The capitalized amounts are then expensed as the related goods are delivered or when the services are performed.

## **Stock-Based Compensation**

The Company recognizes compensation expense for all stock-based awards based on the grant-date estimated fair values, which the Company determines using the BSM option pricing model, on a straight-line basis over the requisite service period for the award. The Company accounts for forfeitures as they occur.

The BSM option pricing model incorporates various highly sensitive assumptions, including the fair value of our common stock, expected volatility, expected term and risk-free interest rates. The weighted average expected life of options was calculated using the simplified method as prescribed by the SEC's Staff Accounting Bulletin, Topic 14 ("SAB Topic 14"). This decision was based on the lack of relevant historical data due to our limited historical experience. In addition, due to our limited historical data, the estimated volatility also reflects the application of SAB Topic 14, incorporating the historical volatility of comparable companies whose stock prices are publicly available. The risk-free interest rate for the periods within the expected term of the option is based on the U.S. Treasury yield in effect at the time of grant. The dividend yield was zero, as we have never declared or paid dividends and have no plans to do so in the foreseeable future.

## **Income Taxes**

The Company accounts for income taxes under the liability method. Under this method, deferred tax assets and liabilities are determined based on the difference between the financial statement and tax basis of assets and liabilities using enacted tax rates in effect for the year in which the differences are expected to affect taxable income. Valuation allowances are established when necessary to reduce deferred tax assets to the amounts expected to be realized.

The Company assesses all material positions taken in any income tax return, including all significant uncertain positions, in all tax years that are still subject to assessment or challenge by the relevant taxing authorities. Assessing an uncertain tax position begins with the initial determination of the position's sustainability and is measured at the largest amount of benefit that is greater than 50% likely of being realized upon ultimate settlement. At each balance sheet date, unresolved uncertain tax positions must be reassessed, and the Company will determine whether (i) the factors underlying the sustainability assertion have changed and (ii) the amount of the recognized benefit is still appropriate. The recognition and measurement of tax benefits requires significant judgment. Judgments concerning the recognition and measurement of a tax benefit might change as new information becomes available. The Company's policy is to recognize interest or penalties related to income tax matters in income tax expense.

**Comprehensive Loss**

The Company has no items of comprehensive income or loss other than net loss.

**Loss Per Share**

Basic loss per share is calculated by dividing net loss for the period by the weighted-average number of common shares outstanding during the period, without consideration for potentially dilutive securities. Diluted net loss per share is computed by dividing the net loss by the weighted-average number of common shares and potentially dilutive securities outstanding for the period.

In March 2021 and in August 2021, the Company issued 124,789 and 634,600 dividend shares, respectively, to certain common stockholders with a fair value of approximately \$986,000 and approximately \$3.1 million, respectively, (see Note 9) which is included in the net loss available to common stockholders for the year ended December 31, 2021 in the below table.

For the years ended December 31, 2021 and 2020, there is no difference in the number of shares used to compute basic and diluted net loss per share due to the Company's net loss position. The following tables presents the computation of the basic and diluted net loss per share (in thousands, except share and per share data):

	Year Ended December 31,	
	2021	2020
<b>Numerator:</b>		
Net loss available to common stockholders	\$ (46,320)	\$ (22,333)
<b>Denominator:</b>		
Weighted-average common shares outstanding used in computing net loss per share available to common stockholders, basic and diluted	12,291,600	9,168,744
Basic and diluted net loss per share	\$ (3.77)	\$ (2.44)

The following potentially dilutive securities were excluded from the computation of diluted net loss per share for the periods presented because including them would have been antidilutive:

	Year Ended December 31,	
	2021	2020
Stock options to purchase common stock	1,905,459	1,550,956
Common stock warrants	3,592,905	2,052,128
	<u>5,498,364</u>	<u>3,603,084</u>

**JOBS Act Accounting Election**

The JOBS Act permits an "emerging growth company" such as us to take advantage of an extended transition period to comply with new or revised accounting standards applicable to public companies. We are choosing to take advantage of this provision and, as a result, we will adopt the extended transition period available under the JOBS Act until the earlier of the date we (i) are no longer an emerging growth company or (ii) affirmatively and irrevocably opt out of the extended transition period provided under the JOBS Act.

**Recently Issued Accounting Pronouncements not yet adopted as of December 31, 2021*****Accounting Standards Update 2016-02, 2018-11 and 2019-01***

In February 2016, the FASB issued ASU 2016-02, *Leases (ASC 842)*. In July 2018, the FASB issued ASU 2018-10, *Codification Improvements to ASC 842, Leases*, which provides clarification to ASU 2016-02. These ASUs (collectively, the new lease standard) require an entity to recognize a lease liability and a right-of-use asset on the consolidated balance sheet for leases with lease terms of more than twelve months. Lessor accounting is largely unchanged, while lessees will no longer be provided with a source of

off-balance sheet financing. Initial guidance required the adoption of the new lease standard using the modified retrospective transition method. In July 2018, the FASB issued ASU 2018-11, *Leases (ASC 842)-Targeted Improvements*, which allows entities to elect an optional transition method where entities may continue to apply the existing lease guidance during the comparative periods and apply the new lease requirements through a cumulative effect adjustment in the period of adoptions rather than in the earliest period presented. In March 2019, FASB issued ASU 2019-01, *Codification improvements*, which provides clarification on implementation issued associated with adopting ASU 2016-02. ASU 2019-01 enhances the guidance in ASC 842 surrounding the fair value of underlying assets for lessors, presentation of sales-type and direct financing leases on the consolidated statement of cash flows, and transition guidance surrounding accounting changes and error corrections.

As a result of the Company having elected the extended transition period for complying with new or revised accounting standards pursuant to Section 107(b) of the JOBS Act, the new leasing standard updates would be effective for the Company for the year ended December 31, 2022, and all interim periods within the year ended December 31, 2023. The Company has adopted ASU 2016-02 as of January 1, 2022 and will record a right-of-use asset and leasehold liability on the consolidated balance sheet.

#### ***Accounting Standards Update 2016-13***

In June 2016, the FASB issued ASU 2016-13, “*Financial Instruments- Credit Losses (ASC 326)*”, which is intended to provide financial statement users with more useful information about expected credit losses on financial assets held by a reporting entity at each reporting date. The new standard replaces the existing incurred loss impairment methodology with a methodology that requires consideration of a broader range of reasonable and supportable forward-looking information to estimate all expected credit losses. For public business entities, ASU 2016-13 is effective for fiscal years and interim periods within those years beginning after December 15, 2020. As a result of the Company having elected the extended transition period for complying with new or revised accounting standards pursuant to Section 107(b) of the JOBS Act, ASU 2016-13 is effective for the Company for the fiscal year ending on December 31, 2022, and all interim periods within. Early adoption is permitted. The Company does not expect the adoption of ASU 2016-13 to have an impact on the Company’s consolidated financial statements and disclosures.

#### ***Accounting Standards Update 2019-12***

In December 2019, the FASB issued ASU 2019-12, “*Simplifying the Accounting for Income Taxes (ASC 740)*”, which removes certain exceptions to the general principles in Topic 740 and improves consistent application of and simplifies U.S. GAAP for other areas of Topic 740 by clarifying and amending existing guidance. For public entities, the ASU 2019-12 is effective for fiscal years and interim periods within those years beginning after December 15, 2020. As a result of the Company having elected the extended transition period for complying with new or revised accounting standards pursuant to Section 107(b) of the JOBS Act, ASU 2019-12 is effective for the Company for the fiscal year ending on December 31, 2022, and all interim periods within. Early adoption is permitted. The Company does not expect the adoption of ASU 2019-12 to have an impact on the Company’s consolidated financial statements and disclosures.

### **3. Fair Value Disclosure**

Fair value is defined as the exchange price that would be received for an asset or an exit price paid to transfer a liability in the principal or most advantageous market for the asset or liability in an orderly transaction between market participants on the measurement date. Valuation techniques used to measure fair value must maximize the use of observable inputs and minimize the use of unobservable inputs.



The fair value hierarchy defines a three-level valuation hierarchy for disclosure of fair value measurements as follows:

- Level 1 Unadjusted quoted prices in active markets for identical assets or liabilities;
- Level 2 Inputs other than quoted prices included within Level 1 that are observable, unadjusted quoted prices in markets that are not active, or other inputs that are observable or can be corroborated by observable market data for substantially the full term of the related assets or liabilities; and
- Level 3 Unobservable inputs that are supported by little or no market activity for the related assets or liabilities.

The categorization of a financial instrument within the valuation hierarchy is based upon the lowest level of input that is significant to the fair value measurement. The carrying value of the Company's cash and cash equivalents, restricted cash, prepaid expenses and other current assets, other assets, accounts payable, accrued liabilities, and insurance financing note payable approximate fair value due to the short-term nature of these items.

#### 4. Balance Sheet Components

##### Property and Equipment, net

Property and equipment, net consist of the following (in thousands):

	December 31, 2021	December 31, 2020
Lab equipment	\$ 2,390	\$ 2,200
Computer equipment and software	25	25
Construction in progress	—	188
Leasehold improvements	527	—
Total property and equipment	2,942	2,413
Less: Accumulated depreciation	(1,585)	(1,155)
Property and equipment, net	\$ 1,357	\$ 1,258

Depreciation expense was approximately \$430,000 and \$332,000 for years ended December 31, 2021 and 2020.

In October 2020, the Company entered into a lease agreement for its new headquarters facility in Los Gatos, California (see Note 13). The Company moved into the new facility in December 2020 and recorded approximately \$188,000 in construction in progress related to leasehold improvements made by the Company related to the new facility.

The Company substantially completed construction in progress related to leasehold improvements made by the Company related to the new facility. As a result, approximately \$527,000 was recorded to leasehold improvements including approximately \$188,000 of construction in progress that had been recorded in 2020.

##### Intangible Assets, net

Intangible assets, net consist of the following (in thousands):

	December 31, 2021	December 31, 2020
Licenses	\$ 81	\$ 81
Less: Accumulated amortization	(59)	(54)
Intangible assets, net	\$ 22	\$ 27

Amortization expense was approximately \$5,000 for both years ended December 31, 2021 and 2020, respectively.

The estimated acquired intangible amortization expense for the next five fiscal years is as follows (in thousands):

<u>Year ending December 31,</u>	
2022	\$ 5
2023	5
2024	5
2025	5
2026	2
Total	<u>\$ 22</u>

## **Licenses**

### University Licensing Agreements

#### *The University of Chicago-Exclusive Patent License Agreement*

We are party to an exclusive licensing agreement with The University of Chicago (UOC), a non-profit university. This agreement granted to us an exclusive, royalty-bearing license for staph alpha toxin technology. The UOC agreement also granted to us the right to sublicense. UOC retained the non-transferrable right to use such patent rights for academic and research purposes, and also to certain pre-existing rights of the U.S. government. We paid upfront fees upon the execution of the agreement and are obligated to pay an annual maintenance fee. We also are obligated to pay UOC low single digit percentage royalties on net sales from our and our sublicensee's sale of any commercialized licensed product or process, and certain other payments, subject to a minimum amount. The aggregate milestone payments under the UOC agreement potentially total up to \$1.6 million. No milestones were met or accrued for during 2021. A \$100,000 milestone was accrued for at December 31, 2020. We are responsible for our pro rata share of patent expenses.

The agreement provides that we have certain obligations to conduct further research and development, and are obligated to utilize reasonable efforts to commercialize, either directly or through a sublicensee, the licensed UOC patent rights as licensed products or processes.

The term of the agreement continues until all patents and filed patent applications, included within the licensed UOC patents, have expired or been abandoned, or until the agreement is earlier terminated. We may terminate the agreement on prior written notice to UOC. Each party has the right to terminate the agreement for the other party's uncured material breach of obligations under the agreement.

#### *The Brigham and Women's Hospital, Inc.-Exclusive Patent License Agreement*

We are party to an exclusive licensing agreement with The Brigham and Women's Hospital, Inc. (BWH), a non-profit corporation. This agreement granted to us an exclusive, royalty-bearing license under its and Beth Israel Deaconess Medical Center's (BIDMC) rights in methods and composition relating to specific binding peptides to *P. aeruginosa* mucoid exopolysaccharide to make, use and sell products and processes for the treatment of pseudomonas infections in humans that are covered by such patent rights. The BWH agreement also granted to us the right to sublicense. BWH and BIDMC retained the non-transferrable right to use such patent rights for academic and research purposes, and also to certain pre-existing rights of the U.S. government. We also are obligated to pay BWH low single digit percentage royalties on net sales from our and our sublicensee's sale of any commercialized licensed product or process, and certain other payments. The aggregate milestone payments under the BWH agreement potentially total up to \$860,000. No milestones were met or accrued for during 2021 or 2020. We are responsible for diligently prosecuting and maintaining the licensed patent rights, at our sole cost and expense.

The agreement provides that we have certain obligations to conduct further research and development, and are obligated to utilize reasonable efforts to commercialize, either directly or through a sublicensee, the licensed BWH patent rights as licensed products or processes.

The term of the agreement continues until all patents and filed patent applications, included within the licensed BWH patents, have expired or been abandoned, or until the agreement is earlier terminated. We may terminate the agreement on prior written notice

to BWH. Each party has the right to terminate the agreement for the other party's uncured material breach of obligations under the agreement.

*The University of Iowa Research Foundation-Exclusive Patent License Agreement*

We are party to an exclusive licensing agreement with The University of Iowa Research Foundation (UIRF). The UIRF agreement granted to us an exclusive, royalty-bearing license under its rights in methods relating to gallium containing compounds for the treatment of infections to make, use and sell products that are covered by such patent rights. The UIRF agreement also granted to us the right to sublicense. UIRF retained the right and ability to grant right to use such patent rights for academic and research purposes, and also to certain pre-existing rights of the U.S. government including the United States Department of Veterans Affairs. We also are obligated to pay UIRF low single digit percentage royalties on net sales from our and our sublicensee's sale of any commercialized licensed product or process, and certain other payments. The aggregate milestone payments under the UIRF agreement potentially total up to \$712,500. No milestones were met or accrued for during 2020. A milestone was met and \$75,000 was accrued for as of December 31, 2021. We are responsible for diligently prosecuting and maintaining the licensed UIRF patent rights, at our sole cost and expense.

The agreement provides that we have certain obligations to conduct further research and development, and are obligated to utilize reasonable efforts to commercialize, either directly or through a sublicensee, the licensed UIRF patent rights as licensed products or processes.

The term of the agreement continues until the expiration of the last to expire patents, included within the licensed UIRF patents, or until the agreement is earlier terminated. We may terminate the agreement on prior written notice to UIRF. Each party has the right to terminate the agreement for the other party's uncured material breach of obligations under the agreement.

*Brigham Young University-Exclusive Patent License Agreement*

We are party to an exclusive licensing agreement with Brigham Young University (BYU). This agreement granted to us an exclusive, royalty-bearing license under its rights in stabilization of biological agents methods relating to human vaccines to make, use and sell products that are covered by such patent rights. The agreement also granted to us the right to sublicense. BYU and the Church of Jesus Christ of Latter-day Saints and the Church Education System retained the right and ability to use such patent rights for academic and ecclesiastical purposes and also to purchase products using such patents rights at a discounted price. We also are obligated to pay BYU low single digit percentage royalties on net sales from our and our sublicensee's sale of any commercialized licensed product, and certain other payments. The aggregate milestone payments under the BYU agreement potentially total up to \$400,000. No milestones were met or accrued for during 2021 or 2020. BYU is responsible for diligently prosecuting and maintaining the licensed BYU patent rights and we reimburse them for one-third of their costs.

The agreement provides that we have certain obligations to conduct further research and development, and are obligated to utilize reasonable efforts to commercialize, either directly or through a sublicensee, the licensed BYU patent rights as licensed products or processes.

The term of this agreement continues until the expiration of the last to expire patents, included within the licensed BYU patents, or until the agreement is earlier terminated. We may terminate the agreement on prior written notice to BYU. Each party has the right to terminate the agreement for the other party's uncured material breach of obligations under the agreement.

*The University of Alabama at Birmingham Research Foundation — Exclusive Patent License Agreement*

In September 2020, the Company entered into an exclusive licensing agreement with the *University of Alabama at Birmingham Research Foundation* ("UABRF"), a non-profit corporation. This agreement granted the Company an exclusive, royalty-bearing license for intellectual property entitled human neutralizing antibodies against SARS-CoV-2/COVID-19. UABRF and Texas Biomedical Research Institute ("Texas Biomed") jointly own all rights, title and interest in the intellectual property. The UABRF license agreement also granted to the Company the right to sublicense the technology. UABRF retained the non-transferrable right to use such patent rights for academic and research purposes, and also to certain pre-existing rights of the U.S. government.

The Company has agreed to provide at least \$50,000 in research funding to each of the two lead inventor's research programs. This funding was supplied under research agreements between the Company, UABRF and Texas Biomed, and the intellectual property

## [Table of Contents](#)

resulting from such research shall be included under this exclusive license agreement. The potential development and commercialization milestone payments under the UABRF agreement total up to approximately \$5.5 million. No milestones were met or accrued for as of December 31, 2021 and 2020. The Company is also obligated to pay UABRF single digit percentage royalties on net sales from us and our sublicensee's sale of any commercialized licensed product or process, subject to minimum annual amounts starting in 2026. The Company is obligated to pay UABRF double digit percentage royalties on non-royalty income received during the term of the license agreement, and payments will be reduced by one half for non-royalty income received for a combination product as defined in the agreement. No milestones were met or accrued for as of December 31, 2021 and 2020. The Company is responsible for all patent protection expenses.

The term of the license agreement continues until all patents and filed patent applications, included within the licensed UABRF patents, have expired, or been abandoned, or until the agreement is earlier terminated. The Company may terminate the license agreement by giving no less than ninety (90) days prior written notice to UABRF. UABRF has the right to immediately terminate the license agreement upon the Company's uncured material breach of obligations under the agreement.

### *Broad Institute of MIT and Harvard — Non-Exclusive Manufacturing License Agreement*

We entered into a non-exclusive manufacturing licensing agreement with the Broad Institute of MIT and Harvard (the "Broad Institute") to make and manufacture CRISPR Modified Cell Lines, CRISPR Modified Animals and CRISPR Modified Plants. These license rights permit the non-exclusive use of the CRISPR Technology for the creation of and improvement of yield from protein and mAb production cell lines, which is one of the core components of the  $\square$ PEXTM mAb discovery and manufacturing production technology.

We are obligated to pay to the Broad Institute an issue fee of \$25,000, an annual license maintenance fee of \$50,000 in 2022, and fees of \$100,000 in 2023 and each year thereafter. Additionally, we are obligated to pay a royalty of 7% of all service income received from a customer for the manufacture, sale or transfer of CRISPR modified cell line, CRISPR Modified Animals and CRISPR Modified Plants or end products, as well as 0.5% of end product net sales from use of any commercialized product that contains any small or large molecule made through the use of a CRISPR modified cell line, CRISPR Modified Animals and CRISPR Modified Plants. The term of the license agreement continues until all patents and filed patent applications, included within the licensed Broad Institute patents, have expired or been abandoned.

### Non-Profit Licensing Agreements

#### *Program for Appropriate Technology in Health and PATH Vaccine Solutions*

We granted the Program for Appropriate Technology in Health (PATH), a global non-profit organization, and the PATH Vaccine Solutions a non-exclusive license, with right to sublicense formulations, for use with the measles, rotavirus, live-attenuated influenza, pneumococcal and enteric vaccines only for sale in developing countries.

We have also agreed to provide rotavirus vaccines to public sector purchasers in developing countries at a preferential price relative to private sector purchasers in developing countries where the rotavirus vaccine utilizing the enabling formulation technology is offered for sale.

### Corporate Licensing Agreements

#### *MedImmune Limited - License Agreement*

In July 2021, the Company executed a license agreement effective July 12, 2021 and entered into an amendment to the license agreement on August 9, 2021 (collectively the "MedImmune License Agreement") with MedImmune Limited ("MedImmune"), pursuant to which MedImmune granted the Company an exclusive worldwide license for the development and commercialization of suvratoxumab, a Phase 3 ready fully human monoclonal antibody targeting the staphylococcus aureus alpha toxin (the "Licensed Product"). As consideration for the MedImmune License Agreement, the Company issued 884,956 shares of its common stock to MedImmune and a \$5.0 million cash payment is due to MedImmune upon the earlier of (i) a registered direct offering in which the Company receives third-party funding or (ii) December 31, 2021. The \$5.0 million liability has not been paid and therefore has been included in accrued liabilities within the Company's consolidated balance sheet at December 31, 2021, and recorded as research and

development expense within its consolidated statement of operations for the year ended December 31, 2021. The fair value of the 884,956 shares of the Company's common stock issued in connection with the MedImmune License agreement is approximately \$6.5 million (see Note 9) which the Company recognized as research and development expense within its consolidated statement of operations and additional paid-in capital within equity in its consolidated balance sheet during the year ended December 31, 2021.

As additional consideration, the Company will pay MedImmune milestone payments upon the achievement of certain regulatory approvals, for one licensed product, up to a total aggregate amount of \$30.0 million and sales related milestone payments of up to \$85.0 million. There are no development milestone payments. MedImmune is entitled to royalty payments based on aggregate net sales ranging from 12.5% to 15% dependent on net sales volume. Further, until delivery of an interim data readout, or an interim futility analysis, from the first Phase 3 clinical study for any indication, MedImmune has a right of first negotiation regarding any commercial rights that the Company intends to sub-license. The term of the MedImmune License Agreement continues until the expiration of the last royalty term for the last licensed product as defined in the license agreement.

*Kenta Biotech Ltd.*

We are party to an asset purchase agreement with Kenta Biotech Ltd. (Kenta), a for profit corporation (Aktiengesellschaft) duly incorporated in Schlieren (Canton of Zurich, Switzerland), registered under the identification number CH-035.3.035.876-2. The agreement assigned and transferred certain of Kenta's physical assets, contracts and technology to us. The physical assets included all physical assets owned or controlled by Kenta, including but not limited to cell lines, genes, antibodies, diagnostic assays and related documentation, which were related to Kenta's MabIgX technology platform for hybridoma generation and its mAb targeting *S. aureus*, *P. aeruginosa*, *A. baumannii* and RSV. The technology included all intellectual property, including but not limited to patents, patent applications, trademarks, knowhow, trade secrets, regulatory filings, clinical trials, clinical trial information, all supporting documentation and all other related intellectual property which are related to Kenta's MabIgX technology platform for hybridoma generation and its mAb targeting *S. aureus*, *P. aeruginosa*, *A. baumannii* and RSV. The contracts included the contracts and agreements (including all rights and obligations thereunder), whether oral or written, which Kenta has concluded and which pertain to the assets. The contracts were primarily related to the ongoing clinical trial of AR 301.

We were obligated to pay Kenta a fixed purchase price, which was fully paid during 2013 and 2014, and a declining scale of low double digit to low single digit percentage royalties on gross licensing revenues from either our licensing of the assets or net sales revenues actually received by us up to a maximum of \$50 million.

As of December 31, 2021 and 2020, no royalty obligation was due to Kenta.

*Emergent Product Development Gaithersburg Inc.*

We are party to a license agreement with Emergent Product Development Gaithersburg Inc. (Emergent). We granted Emergent an exclusive, perpetual, royalty-bearing license to use certain of our patents and related know how for the prevention or treatment of infection or illness caused by biodefense pathogens. We also granted a non-exclusive, royalty-bearing license to use certain of our patents and related know how for the prevention or treatment of tularemia and viral hemorrhagic fever indications.

Emergent is obligated to pay us low single digit percentage royalties on net sales from their and their sublicensee's sale of any commercialized licensed product, and certain other payments. The aggregate milestone payments that the Company could receive under the Emergent agreement amount to \$2.8 million. The Company is not aware of Emergent achieving any milestones under the agreement and has not received any milestone payments. The Company has certain diligence obligations to conduct further research and development, and to exploit licensed products.

## Accrued Liabilities

Accrued liabilities consist of the following (in thousands):

	December 31, 2021	December 31, 2020
Research and development services	\$ 5,939	\$ 872
Payroll related expenses	416	279
Professional services and other	109	179
Accrued liabilities	<u>\$ 6,464</u>	<u>\$ 1,330</u>

## 5. Equity Method Investment

On February 11, 2018, the Company entered into a joint venture agreement (the “JV Agreement”) with Shenzhen Hepalink Pharmaceutical Group Co., Ltd., a related party, principal shareholder of the Company, and a Chinese entity (“Hepalink”), to develop and commercialize products for infectious diseases. Under the terms of the JV Agreement, the Company contributed \$1.0 million and the license of its technology relating to the Company’s AR-101 and AR-301 product candidates for use in the joint venture company named Shenzhen Arimab BioPharmaceuticals Co., Ltd. (the “JV Entity”) in the territories of the Republic of China, Hong Kong, Macau and Taiwan (the “Territory”) and initially owns 49% of the JV Entity. On July 2, 2018, the JV Entity received final approval from the government of the Peoples Republic of China. It was agreed by the parties that the Company shall be reimbursed for certain legal and contract manufacturing expenses related to the clinical drug supply for a Phase 3 clinical study of AR-301 and the clinical drug supply for a clinical study of AR-105 (see Note 12).

On August 6, 2018, the Company entered into an amendment to the JV Agreement with Hepalink whereby the Company agreed to additionally contribute an exclusive, revocable, and royalty-free right and license to its AR-105 product candidate in the Territory. Pursuant to the JV Agreement and the amendment, Hepalink initially owns 51% of the JV Entity and is obligated to contribute the equivalent of \$7.2 million to the JV Entity. Additionally, Hepalink is obligated to make an additional equity investment of \$10.8 million or more at the time of the JV Entity’s first future financing.

The Company evaluated the accounting for the JV Agreement entered into noting that it did not meet the accounting definition of a joint venture and instead meets the definition of a variable interest entity. The Company concluded that it is not the primary beneficiary of the JV Entity and therefore is not required to consolidate the entity. This conclusion was based on the fact that the equity-at-risk is insufficient to support operations without additional investment and that the Company does not hold decision-making power over activities that significantly impact the JV Entity’s operations. The Company accounted for its investment in the JV Entity as an equity method investment. The Company recorded the equity method investment at \$1.0 million which represents the Company’s contribution into the JV Entity. The Company’s license contributed to the JV Entity was recorded at its carryover basis of \$0.

For the years ended December 31, 2021 and 2020, the Company recognized approximately \$0 and \$9,000 in losses from the operations of the JV Entity, respectively. As of December 31, 2021 and 2020, the Company’s equity method investment in the JV Entity was \$0.

## 6. Collaboration, Development and License Agreements

### Cystic Fibrosis Foundation Development Agreement

In December 2016, the Company received an award from the Cystic Fibrosis Foundation (“CFF”), which was executed under the Development Program Letter Agreement (the “CFF Agreement”), for approximately \$2.9 million. Under the CFF Agreement, CFF made an upfront payment of \$200,000 and will make milestone payments to the Company as certain milestones defined in the agreement are met. The milestones relate to pre-clinical and clinical research activities. The agreement also specifies that we are obligated to cumulatively spend on the development program at least an equal amount that the Company receives from the CFF. In the event that we do not spend as much as we received under the agreement, we are obligated to return any overage to the CFF. In November 2018, the CFF increased the award to approximately \$7.5 million.

As of the adoption date of ASC 606 on January 1, 2019 (the “Adoption Date”), the Company identified the following promises with regards to the clinical research activities under the CFF Agreement that represent an initial contract of: a) Phase 1 single ascending dose (“SAD”) clinical trial, which consists of the satisfied development-based milestones and one development-based milestone in progress which was accounted for as a single performance obligation; and contingent promises of: b) Phase 1 multiple ascending dose (“MAD”) clinical trial, which consists of one development-based milestone that had not yet been started, and c) Phase 2a clinical trial, which consists of four development-based milestones that had not yet been started. Of these promises, the Phase 1 SAD clinical trial was determined to be a distinct performance obligation as of the Adoption Date. For the clinical research activities related to the Phase 1 MAD clinical trial and the Phase 2a clinical trial that had not yet been started, the Company was contingently obligated to perform these clinical research activities only after the previous milestones, which achievement was uncertain, had been met.

The clinical research activities related to the Phase 1 MAD clinical trial and the Phase 2a clinical trial that had not been started were evaluated to determine if they should be considered variable consideration or contingent promises akin to optional purchases under ASC 606. The Company concluded that these two promises that have not been started are contingent promises because there is substantive uncertainty about the contingent event occurring (i.e. milestones being achieved) and the contingent event requires additional distinct services and incremental payments from the CFF. The Company determined that these contingent promises did not provide the CFF with any material rights. The Phase 1 MAD clinical trial and the Phase 2a clinical trial will be accounted for as separate contracts at the time the Company is obligated to perform the underlying clinical research activities.

The Company determined that the consideration for the Phase 1 SAD clinical trial contract included several development-based milestones, which had been achieved as of the Adoption Date, totaling approximately \$1.7 million, and the one development-based milestone in progress as of the Adoption Date of \$1.0 million became probable during the quarter ended March 31, 2019. Prior to March 31, 2019, the amount of the one development-based milestone in progress as of the Adoption Date could not be included in the transaction price as it was contingent on successful completion of Phase 1 SAD clinical trial, and it was not probable that significant reversal of cumulative revenue recognized would not occur if this milestone were included in the transaction price.

The Company determined the consideration for the Phase 1 MAD clinical trial contract included one development-based milestone of \$1.0 million which became probable of achievement and was achieved during the quarter ended June 30, 2020. Prior to June 30, 2020, the amount of the one development-based milestone could not be included in the transaction price for this contract as it was contingent on successful completion of the Phase 1 MAD clinical trial, and it was not probable that a significant reversal of cumulative revenue recognized would not occur if this milestone were included in the transaction price.

The Company determined the consideration for the Phase 2a clinical trial contract totals approximately \$3.8 million which includes four development-based milestones. The Company determined as of December 31, 2021, the transaction price for the Phase 2a clinical trial contract was \$1.0 million as the first of the four development-based milestones was achieved during the year ended December 31, 2021. As of December 31, 2021, the amount of the remaining three development-based milestones could not be included in the transaction price for this contract as it was contingent on successful completion of the remaining three milestones, and it was not probable that a significant reversal of cumulative revenue recognized would not occur if those milestones were included in the transaction price.

The milestones under the CFF Agreement are development-based milestones related to pre-clinical and clinical research activities and the realization of or recognition of revenue associated with the milestones as determined by the completion of the milestones and, if applicable, review and approval of the achievement by the CFF. Each development-based milestone payment has specific criteria that needs to be met, some examples of which include, the completion of certain study activities and approval to move to the next activity. At every reporting period, the Company evaluates the individual facts and circumstances of the development-based milestone to assess whether the revenue attributable to the development-based milestone in progress should be constrained. The constraint assessment by the Company includes an analysis of the key judgements and considerations used for each milestone which include, but are not limited to, the nature and amount of work to be performed, if the work is subject to the approval of the CFF, clinical data and uncertainty with regards to the results of the clinical studies, and the probability of successful clinical studies. The constraint will be removed once the Company achieves the development-based milestone or has determined that there is probable completion of the development-based milestone, and it has also concluded that it is not probable that revenue recognized attributable to the development-based milestone will result in a significant reversal of revenue in the future.

The Company determined that the clinical research activities under the CFF Agreement should be recognized over time by calculating the amount of revenue to recognize in any given period by accumulating the total related costs incurred for the respective

clinical research activities related to that distinct performance obligation using the input method (cost-to-cost) and applies that percentage of completion to the transaction price at each reporting period. The Company believes this method best depicts the transfer of control to the customer, which occurs as the costs related to the clinical research activities are incurred.

For the year ended December 31, 2021, the Company recognized revenue of approximately \$524,000 from the CFF Agreement, mainly due to the achievement of the first of four development-based milestones related to the Phase 2a clinical trial in 2021. The Company recorded a contract liability for the remaining consideration for achieving the first milestone of approximately \$476,000 to deferred revenue, current, on its consolidated balance sheet as of December 31, 2021. For the year ended December 31, 2020, the Company recognized \$1.0 million in revenue from the CFF Agreement, mainly due to the achievement in 2020 of one development-based milestone related to the Phase 1 MAD clinical trial.

#### **Gates Foundation Grant Agreement**

On October 15, 2021, the Company entered into an agreement with the Bill and Melinda Gates Foundation (“Gates Foundation” or “BMGF”) by executing a Grant Agreement identified as Investment ID INV-033376 (“Grant”). The goal of the Grant Agreement, is to develop durable approaches to block the infection and transmission of pathogens. For providing research and development services under the Grant Agreement, the Gates Foundation has agreed to compensate the Company \$1.93 million due upon execution of the Grant Agreement. In return, we agreed to conduct a proof-of-concept study seeking to demonstrate that inhaled neutralizing antibodies are effective for preventing viral infection and transmission. We are required to ensure global access which means that the knowledge and information gained from the project will be promptly and broadly disseminated, and that the products, technologies, materials, processes and other intellectual property resulting from the proof-of-concept study (collectively referred to as the Funded Developments) will be made available and accessible at an affordable price (i) to people most in need within developing countries or (ii) in support of the U.S. educational system and public libraries. Consistent with our Global Access commitments, if the project description specifies publication or publication is otherwise requested by the Gates Foundation, the Company will seek prompt Publication of any Funded Developments consisting of data and results. These obligations survive any expiration or termination of the grant agreement.

Under the Grant Agreement, the Gates Foundation made an upfront payment of \$1.93 million. The Agreement specifies that we may not use funds provided under the Grant Agreement for any purpose other than the project. The Company is required to repay any portion of the funds used or committed in material breach of the Grant Agreement. Any grant funds, plus any income, that have not been used for, or committed to, the Project upon expiration or termination of the Agreement, must be returned promptly to the Gates Foundation. The Company is required to maintain grant funds in a physically separate bank account or a separate bookkeeping account maintained as part of the Company’s financial records and dedicated to the project.

The Company will conduct research and development services up until the proof-of-concept study is completed, at which point the Gates Foundation will determine whether to approve further grant funding for transmission studies or end the study in which case the Company will no longer provide any significant goods or services. The Company will partner with three main subcontractors to deliver the scope of work described in the investment document. The Gates Foundation’s role is limited to advisory participation and participation in review meetings. If the Gates Foundation decides not to proceed with the transmission studies described in the Investment Document, the Company will not undertake any additional activities or incur any substantial costs outside the Grant Agreement.

The Grant Agreement is considered within the scope of ASC 606 as the parties have a customer/vendor relationship and are not exposed equally to the risks and rewards of the research and development services contemplated in the Grant Agreement. The Company identified the following promises under the Agreement: 1) research and development services, 2) global access commitment, 3) humanitarian license, 4) publication if requested by the Gates Foundation, and 5) intellectual property reporting upon request. The Company determined that these promises are not distinct from each other, and therefore represent one performance obligation.

Since the Company is required to update the Gates Foundation on technical progress during each stage of the Funded Development, the ability to access research and development results represents the Gates Foundation’s consumption of the benefits from the Company’s research and development activities. As such, research and development services revenue is recognized over time. At each reporting period, the amount of revenue to recognize is calculated using the input method (cost-to-cost), by comparing cumulative costs incurred to the total estimated costs to perform the research and development services and applying that percentage of completion to the transaction price. The Company believes this method best depicts the transfer of control to the customer, which occurs as the costs related to the research and development services are incurred.



For the year ended December 31, 2021, the Company recognized revenue of approximately \$546,000 from the Grant Agreement, based on expenses incurred and paid to partners to assist with the research and development services. The Company recorded a contract liability for the remaining consideration of approximately \$1,387,000 to deferred revenue, current, on its consolidated balance sheet as of December 31, 2021.

### **Serum License Agreement**

In July 2019, the Company and Serum International B.V. (“SIBV”), an affiliate of Serum Institute of India Private Limited, entered into an option agreement which granted SIBV the option to license multiple programs from the Company and access the Company’s MabIgX® platform technology for asset identification and selection. The Company received an upfront cash payment of \$5 million upon execution of this option agreement. In connection with the option agreement, SIBV made an equity investment whereby the Company issued 801,820 shares of its restricted common stock in a private placement to SIBV for total gross proceeds of \$10 million. As a result of this transaction, SIBV and its affiliates, are considered related parties to the Company.

In September 2019, the Company and Serum AMR Products (“SAMR”), a party under common ownership of SIBV, entered into a License, Development and Commercialization Agreement (the “License Agreement”). Pursuant to the License Agreement, the Company granted to SAMR exclusive licenses, and rights to sublicense, certain patent rights and technology related know-how to the Company’s products AR-301, AR-105, AR-101 (i.e. exclusive rights to, among other things, develop, distribute, market, promote, sell, import and otherwise commercialize) in (a) the country of India, and (b) all other countries of the world except the USA, Canada, EU Territory, UK, China, Australia, South Korea, Brazil, New Zealand, and Japan (products AR-105 and AR-101 countries do not exclude South Korea and Brazil) (the “Limited Territory”); and AR-201 (i.e. exclusive rights to, among other things, develop, manufacture, make, distribute, market, promote, sell, import and otherwise commercialize) in all countries of the world except China, Hong Kong, Macau and Taiwan (the “Worldwide Territory”) (the “licenses and know-how”). Further, the License Agreement grants SAMR an option for the Company to provide research services using its MabIgX® platform technology for the identification of up to five (5) candidates including product development of these identified candidates and an exclusive license to develop, manufacture, make, distribute, market, promote, sell, import and otherwise commercialize these development products in the Worldwide Territory (the “research and development option”).

Pursuant to the License Agreement, the Company will provide development support related to the licensed products above in order to assist SAMR in its efforts to develop, receive regulatory approval, and manufacture and sell the licensed products in SAMR’s authorized territories which will be performed under the direction of a Joint Steering Committee (“JSC”) which the Company will participate in (collectively “development support services”).

In addition, under the License Agreement, SAMR was granted an exclusive manufacturing license option as the initial license granted above for AR-301, AR-105 and AR-101 does not allow for manufacturing. This manufacturing option provides incremental rights related to these products beyond what is granted as part of the licensing discussed above (the “manufacturing rights option”). If this option is exercised, after SAMR has met certain requirements to exercise the option as defined in the License Agreement, it would provide for an exclusive license for use by SAMR to manufacture and supply the products for SAMR’s own use in the Limited Territory and to manufacture and supply these products to the Company, or their affiliates, for the Company’s use outside the Limited Territory. Should SAMR exercise the development and research option or the manufacturing rights option discussed above, SAMR and the Company shall negotiate in good faith the economic terms around these arrangements. If a third-party sublicensee of AR-301, AR-105 and AR-101 wishes to manufacture these products by itself for the territory for which it has a license from the Company, then the Company shall have the right to buy back the manufacturing rights for all territories outside of the Limited Territory by paying to SAMR \$5 million.

Under the License Agreement, the Company received upfront payments totaling \$15 million, of which \$5 million was received in July 2019 through the option agreement referred to above. The Company is also entitled to additional payments from SAMR of up to \$42.5 million, conditioned upon the achievement of specified milestones related to completion of certain trials and regulatory approvals as defined in the License Agreement. Further, the Company may receive additional royalty-based payments from SAMR if certain sales levels on licensed products are achieved as defined in the License Agreement.

Given the equity investment by SIBV was negotiated in conjunction with the option agreement, which resulted in the execution of the License Agreement, all arrangements were evaluated as a single agreement and amounts were allocated to the elements of the arrangement based on their fair value. The Company recorded approximately \$5.0 million, which represented the fair value of the

restricted common stock issued of \$5.4 million, net of \$441,000 of issuance costs, to stockholders' equity within the Company's consolidated balance sheet as of December 31, 2019. The Company allocated the net \$4.6 million from the equity investment, after deducting commissions and offering costs, to the License Agreement. Therefore, the Company recorded approximately \$19.6 million to deferred revenue based on the \$15.0 million from upfront payments under the License Agreement and approximately \$4.6 million from the equity allocation.

The License Agreement is determined to be within the scope of ASC 606, as the transaction represents a contract with a customer where the participants function in a customer/vendor relationship and are not exposed equally to the risks and rewards of the activities contemplated under the License Agreement. Using the concepts of ASC 606, the Company identified the following performance obligations under the License Agreement: 1) the transfer of licenses of the intellectual property for AR-301, AR-101, AR-105 and AR-201, inclusive of the related technology know-how conveyance (referred to as the license and know-how above); and 2) the Company to deliver ongoing development support services related to the licensed products and the Company's participation in the JSC (referred to as the development support services above); and identified the following material promises under the License Agreement: 3) SAMR was granted a research and development option of up to five identified product candidates for the Company to perform including specific development services (the research and development option referred to above); and 4) SAMR was granted an exclusive manufacturing license option which would provide for incremental manufacturing rights related to AR-301, AR-105 and AR-101 beyond what is granted in the License Agreement (the manufacturing rights option referred to above). The Company concluded that the performance obligations and material promises identified are separate and distinct from each other.

The Company is also entitled to additional payments from SAMR of up to \$42.5 million, conditioned upon the achievement of specified milestones related to completion of certain trials and regulatory approvals as defined in the License Agreement. Further, the Company may receive additional royalty-based payments from SAMR if certain sales levels on licensed products are achieved as defined in the License Agreement. The Company concluded that these milestones and royalty payments each contain a significant uncertainty associated with a future event. As such, these milestone and royalty payments are constrained at contract inception and are not included in the transaction price as the Company could not conclude that it is probable a significant reversal in the amount of cumulative revenue recognized will not occur surrounding these payments. At the end of each reporting period, the Company will update its assessment of whether the milestone and royalty payments are constrained by considering both the likelihood and magnitude of the potential revenue reversal. At December 31, 2021 and 2020 the Company performed an assessment and determined that these milestone and royalty payments are constrained.

The Company determined that the transaction price under the License Agreement was \$19.6 million, consisting of the \$15.0 million from upfront payments under the License Agreement and approximately \$4.6 million from the equity allocation as noted above, which was allocated among the performance obligations and material promises based on their respective related standalone selling prices. The Company allocated the \$19.6 million transaction price to the following: approximately \$14.5 million to the licenses and know-how; approximately \$79,000 to the development support services; approximately \$892,000 to the research and development option; and approximately \$4.1 million to the manufacturing rights option.

The Company determined that the intellectual property licensed under the License Agreement represents functional intellectual property and it has significant standalone functionality and therefore should be recognized at a point in time upon satisfying the performance obligations. The Company will satisfy the performance obligations upon transfer of the licenses and know-how to SAMR, and expects to satisfy these performance obligations by the end of the third quarter of 2022.

The Company determined that no performance obligations or material promises were satisfied as of December 31, 2021, and therefore, no revenue related to the License Agreement was recognized for the years ended December 31, 2021 and 2020. The Company has recorded contract liabilities resulting from the License Agreement of approximately \$18.6 million and \$18.7 million to deferred revenue, current, and approximately \$913,000 and \$854,000 to deferred revenue, noncurrent, on its consolidated balance sheets as of December 31, 2021 and 2020, respectively. The Company capitalized a contract asset resulting from the License Agreement of approximately \$2.1 million related to the incremental costs of obtaining the License Agreement on its consolidated balance sheets, of which approximately \$2.0 million and \$2.0 million is classified as current, and approximately \$96,000 and \$90,000 is classified as noncurrent, as of December 31, 2021 and December 31, 2020, respectively.

## **Kermode Licensing and Product Discovery Agreement**

In February 2021, the Company entered into an out-licensing and product discovery agreement, and a statement of work (collectively, the “Kermode Agreement”) with Kermode Biotechnologies, Inc. (“Kermode”). Under the terms of this agreement, Kermode will fund for one year the discovery of product candidates for African Swine Fever Virus (“ASFV”) with an option to include the discovery of product candidates for swine influenza virus (“SIV”). Kermode also received exclusive rights to all mAbs and vaccines discovered for veterinary uses and rights to a non-exclusive license to use the Company’s APEX technology platform for further development activities. The Company retained exclusive rights to mAbs and vaccines discovered for human uses. In March 2021, the Company received a nonrefundable upfront payment of \$500,000 and received one milestone payment of \$250,000 in December 2021. The Company will receive one more milestone payment of \$250,000 from Kermode after certain research and development phases in the agreement are completed. The Kermode Agreement defines four phases of research and development activities. The Company is also entitled to royalty payments based on future net sales if Kermode is ultimately successful in commercializing product candidates.

The Kermode Agreement is within the scope of ASC 606 as the parties have a customer/vendor relationship and are not exposed equally to the risks and rewards of the activities contemplated in the Kermode Agreement. The Company identified the following promises under the Kermode Agreement: 1) research and development services, and 2) license rights of the APEX Platform and mAbs and vaccines (“Program IP”). The Company determined that these promises are not distinct from each other, and therefore represent one performance obligation.

As of December 31, 2021, the transaction price of the Kermode Agreement was \$750,000, consisting of the nonrefundable upfront payment and one milestone payment. Another milestone payment of \$250,000, and potential royalty payments were not included in the transaction price, as it was not probable that a significant reversal of cumulative revenue recognized would not occur if these amounts were included. At the end of each reporting period, the Company will update its assessment of whether the milestone payment and royalties are constrained by considering both the likelihood and magnitude of the potential revenue reversal.

The Company determined that the one performance obligation under the Kermode Agreement should be recognized over time. At each reporting period, the amount of revenue to recognize will be calculated using the input method (cost-to-cost), by comparing cumulative costs incurred to the total estimated costs to perform all four phases of the research and development activities, and applying that percentage of completion to the transaction price. The Company believes this method best depicts the transfer of control to the customer, which occurs as the costs related to the research and development activities are incurred.

For year ended December 31, 2021, the Company recognized approximately \$465,000 in revenue related to the Kermode Agreement. The Company has recorded the remaining portion of the nonrefundable upfront payment as a contract liability of approximately \$285,000 to deferred revenue, current, as of December 31, 2021.

## **7. Notes Payable**

### **Note Purchase Agreement**

On November 23, 2021, the Company entered into an agreement (“Note Purchase Agreement”) with Streeterville Capital, LLC (Lender), pursuant to which we issued to the Lender a secured promissory note (Note) in the aggregate principal amount of \$5,250,000. Closing occurred on November 23, 2021 (Issuance Date). The Note carries an original issue discount of \$250,000. The Note bears interest at the rate of 6% per annum and matures on November 23, 2023. Beginning on May 23, 2022, the Lender has the right to redeem all or any portion of the Note up to the Maximum Monthly Redemption Amount which is \$450,000. Payments of each redemption amount must be made in cash. Pursuant to the Note, the Company can defer all redemption payments that the Lender could otherwise elect to make during any calendar month on three (3) separate occasions by providing written notice to Lender at least three (3) trading days prior to the first day of each such calendar month for which it wishes to defer redemptions for that month. In the event the Company elects to defer, the aggregate principal amount plus accrued but unpaid interest (Outstanding Amount) shall automatically be increased by (a) 0.5% for the first exercise; (b) 1% for the second exercise and (c) 1.5% for the third exercise. The Company can prepay all or any portion of the Outstanding Amount at a rate of (a) 105% of the portion of the Outstanding Balance the Company elects to prepay if prepayment occurs on or before the three-month anniversary of the Issuance Date; (b) 107.5% of the portion of the Outstanding Balance the Company elects to prepay if prepayment occurs after the three-month anniversary of the Issuance Date but on or before the six-month anniversary of the Issuance Date and (c) 110% of the Outstanding Balance if the prepayment occurs after the six-month anniversary of the Issuance Date.

Pursuant to the Note Purchase Agreement, we are subject to certain covenants, including the obligations to: (i) timely file all reports required to be filed under Sections 13 or 15(d) of the Securities Exchange Act of 1934, as amended (the “Exchange Act”) and not terminate its status as an issuer required to file reports under the Exchange Act; (ii) maintain listing of our common stock on a securities exchange; and (iii) avoid trading in our common stock from being suspended, halted, chilled, frozen or otherwise ceased. The Note is secured by the Company’s MablGX assets.

The Company elected to apply the fair value option to the measurement of this note. The total initial fair value at issuance was \$5,250,000. The Company remeasured the fair value as of December 31, 2021 and recognized an expense of \$33,000 as the fair value of note had increased. The fair value measurement includes the accrued interest and interest expense, at the stated rate, and thus separate amount is not reflected in the consolidated statement of operations. For the year ended December 31, 2021, the Company recognized approximately \$250,000 in interest expense for the issuance discount related to the note. . The Company has recorded a liability of approximately \$5,282,000 to Note Payable, non-current, as of December 31, 2021. The note matures on November 23, 2023.

### **Insurance Financing**

The Company obtained financing for certain Director & Officer liability insurance policy premiums. The agreement assigns First Insurance Funding (Lender) a first priority lien on and security interest in the financed policies and any additional premium required in the financed policies including (a) all returned or unearned premiums, (b) all additional cash contributions or collateral amounts assessed by the insurance companies in relation to the financed policies and financed by Lender, (c) any credits generated by the financed policies, (d) dividend payments, and (e) loss payments which reduce unearned premiums. If any circumstances exist in which premiums related to any Financed Policy could become fully earned in the event of loss, Lender shall be named a loss-payee with respect to such policy.

The total premiums, taxes and fees financed is approximately \$1,645,000 with an annual interest rate of 3.67%. In consideration of the premium payment by Lender to the insurance companies or the Agent or Broker, the Company unconditionally promises to pay Lender the amount Financed plus interest and other charges permitted under the Agreement. At December 31, 2021 the Company recognized approximately \$696,000 as insurance financing note payable in its consolidated balance sheet. The Company will pay the insurance financing through installment payments with the last payment being on May 14, 2022.

### **Paycheck Protection Program Loan**

The Company applied for and received a loan, which is in the form of a note dated May 1, 2020, from Silicon Valley Bank (“SVB”) in the aggregate amount of approximately \$715,000 (the “Loan”), pursuant to the Paycheck Protection Program (the “PPP”). The PPP, established as part of the Coronavirus Aid, Relief and Economic Security Act (“CARES Act”), provides for loans to qualifying businesses for amounts up to 2.5 times of the average monthly payroll expenses of the qualifying business.

In May 2021, the Company received confirmation that the PPP Loan was forgiven by the SBA and was legally released from its financial obligation by the lender, SVB. As such, for the year ended December 31, 2021, the Company recognized in its consolidated statement of operations a gain on extinguishment of PPP Loan of approximately \$722,000, which includes the PPP Loan principal of approximately \$715,000 and accrued interest of approximately \$7,000. At December 31, 2021, the Company had no liabilities related to the PPP Loan recorded in its consolidated balance sheet.

### **8. Warrants**

In August 2021, the Company entered into a Securities Purchase Agreement (the “August 2021 Securities Purchase Agreement”) with an institutional investor, pursuant to which the Company agreed to offer, issue and sell to this investor, in a registered direct offering, 1,300,000 shares of its Common Stock, pre-funded warrants to purchase up to an aggregate of 3,647,556 shares of Common Stock (the “Pre-Funded Warrants”), and warrants to purchase up to 2,473,778 shares of Common Stock (the “Warrants”). The combined purchase price of each share of Common Stock and accompanying Warrants is \$5.053 per share. The combined purchase price of each Pre-Funded Warrant and accompanying Warrant is \$5.052 (equal to the combined purchase price per share of Common Stock and accompanying Warrant, minus \$0.001). The Company received gross proceeds of approximately \$25.0 million, and after deducting the placement agent fees and expenses and offering costs, net proceeds were approximately \$22.6 million (see Note 9).

Each Warrant is exercisable for one share of Common Stock at an exercise price of \$5.00 per share. The Warrants are immediately exercisable and will expire seven years from the original issuance date, or August 4, 2028. The Pre-Funded Warrants were offered in lieu of shares of Common Stock to the Purchaser whose purchase of shares of Common Stock in the Offering would otherwise result in the Purchaser, together with its affiliates and certain related parties, beneficially owning more than 4.99% (or, at the election of the Purchaser, 9.99%) of the Company's outstanding Common Stock immediately following the consummation of this Offering. Each Pre-Funded Warrant is exercisable for one share of Common Stock at an exercise price of \$0.001 per share. The Pre-Funded Warrants are immediately exercisable and may be exercised at any time until all of the Pre-Funded Warrants are exercised in full. A holder (together with its affiliates) may not exercise any portion of the Warrant or Pre-Funded Warrant, as applicable, to the extent that the holder would own more than 4.99% (or, at the holder's option upon issuance, 9.99%) of the Company's outstanding Common Stock immediately after exercise, as such percentage ownership is determined in accordance with the terms of the Warrant or Pre-Funded Warrant, as applicable. The exercise price of the Warrants and the Pre-Funded Warrants are subject to adjustment in the event of any stock dividends and splits, reverse stock split, recapitalization, reorganization or similar transaction, as described in the Warrants and Pre-Funded Warrants. Each of the Warrants and the Pre-Funded Warrants may be exercised on a "cashless" basis under certain circumstances set forth in the Warrants and Pre-Funded Warrants.

The Company measured the fair value of the Common Stock and Pre-Funded Warrants based on the Company's closing stock price on the date the August 2021 Purchase Agreement was entered into and the fair value of the Warrants was based upon a BSM valuation model. The BSM valuation model used the following assumptions: expected term of seven years, expected volatility of approximately 97%, risk-free interest rate of 0.96%, and dividend yield of 0%. The Company used the relative fair value method to allocate the net proceeds received from the sale of the Common Stock, the Pre-Funded Warrants and the Warrants of approximately \$22.6 million. The Company recorded approximately \$4.4 million, \$12.2 million and \$6 million, which represented the relative fair value of the Common Stock, Pre-Funded Warrants and Warrants, respectively, to stockholders' equity (deficit) within the Company's consolidated balance sheet.

In December 2021, all of the Pre-Funded Warrants were exercised. A total of 3,647,556 shares of Common Stock were issued in exchange for approximately \$4,000 in cash as a result of the exercise.

#### **Warrants Issued in Private Placement**

In October 2020, the Company entered into a Securities Purchase Agreement (the "October 2020 Purchase Agreement") in which the Company agreed to offer, issue and sell (i) in a registered direct offering, an aggregate of 1,134,470 shares (the "Shares") of common stock, par value \$0.0001 per share ("Common Stock") and (ii) in a concurrent private placement, Series A warrants (the "Series A Warrants") and Series B warrants (the "Series B Warrants" and collectively, with the Series A Warrants, the "Warrants") to purchase up to an aggregate 567,234 shares (the "Warrant Shares") of common stock, for aggregate gross proceeds to the Company of approximately \$8.5 million, and after deducting commissions and offering costs, net proceeds were approximately \$7.8 million (See Note 9).

The combined purchase price for each Share, together with one Series A Warrant and one Series B Warrant, is \$7.4925. The Series A Warrants have an exercise price of \$7.43 per share, are exercisable six months from the date of issuance, and expire three and a half years from the date they become exercisable. The Series B Warrants have an exercise price of \$9.00 per share, are exercisable six months from the date of issuance, and expire three and a half years from the date they become exercisable. In addition, the Series B Warrants are redeemable by the Company at \$0.01 per share upon the price of the Company's common stock closing at \$9.00 or more over five (5) consecutive trading days. The exercise price of the Warrants and Warrant Shares are subject to adjustment in the event of any stock dividends and splits, reverse stock split, recapitalization, reorganization or similar transaction, as described in the Series A Warrants and Series B Warrants. Each of the Series A Warrants and the Series B Warrants may be exercised on a "cashless" basis under certain circumstances set forth in the Warrants.

The Company measured the fair value of the Common Stock Shares based on the Company's closing stock price on the date the October 2020 Purchase Agreement was entered into and the fair value of the Warrant Shares was based upon a Black-Scholes valuation. The Black-Scholes valuation used the following assumptions: expected term of four years, expected volatility of 104%, risk-free interest rate of 0.25%, and dividend yield of 0%. The Company used the relative fair value method to allocate the net proceeds received from the sale of the Common Stock Shares and the Warrants Shares of approximately \$7.8 million. The Company recorded approximately \$5.8 million and \$2.0 million, which represented the relative fair value of the Common Stock Shares and Warrant Shares, respectively, to stockholders' equity (deficit) within the Company's consolidated balance sheet.

## 9. Common Stock

As of December 31, 2021, the Company had reserved the following common stock for future issuance:

Shares reserved for exercise of outstanding warrants to purchase common stock	3,592,905
Shares reserved for exercise of outstanding options to purchase common stock	1,905,459
Shares reserved for issuance of future options	228,099
Total	<u>5,726,463</u>

### March 2021 Securities Purchase Agreement

In March 2021, the Company entered into a Securities Purchase Agreement (the “March 2021 Securities Purchase Agreement”) with certain institutional and individual investors (the “Purchasers”), pursuant to which the Company agreed to offer, issue and sell to the Purchasers, in a registered direct offering, an aggregate of 1,037,405 shares (the “Shares”) of the Company’s common stock, par value \$0.0001 per share (“Common Stock”) for aggregate gross proceeds to the Company of approximately \$7.0 million, and after deducting commissions and offering costs, net proceeds were approximately \$6.4 million.

In October 2020, shares of Common Stock were sold in a registered direct offering in which each share contains a price based anti-dilution rights. If the Company issues additional securities at a purchase price less than the purchase price paid by these respective holders, the Company shall issue additional common shares equal to the difference of the number of common shares that each respective shareholder would have received if they paid the subsequent lower price, and the number of shares each respective shareholder originally received. As a result of the March 2021 registered direct offering price per share being less than the October 2020 registered direct offering price per share, the Company was obligated to issue an additional 124,789 shares of unregistered Common Stock to the investors in the Company’s October 2020 registered direct offering pursuant to the anti-dilutive provisions of the October 2020 Securities Purchase Agreement. In March 2021, the Company issued 124,789 dividend shares to certain common stockholders with a fair value of approximately \$986,000, which the Company recorded as a credit to additional paid-in capital, and since the Company has an accumulated deficit, the corresponding debit to additional paid-in capital, resulting in no dollar impact within the Company’s consolidated statement of changes in stockholders’ equity (deficit) for the year ended December 31, 2021.

### MedImmune Limited License Agreement

Effective July 12, 2021, the Company entered into the MedImmune License Agreement, pursuant to which MedImmune granted the Company an exclusive worldwide license for the development and commercialization of suvatocumab, a Phase 3 ready fully human monoclonal antibody targeting staphylococcus aureus alpha toxin (see Note 4). As part of the consideration for the MedImmune License Agreement, the Company issued 884,956 shares of its common stock to MedImmune. The fair value of the 884,956 shares of the Company’s common stock issued in connection with the MedImmune License agreement is approximately \$6.5 million. The Company measured the fair value of the common stock issued to MedImmune based on the Company’s closing stock price on the effective date of the MedImmune License Agreement. The Company recognized the \$6.5 million as research and development expense within its consolidated statement of operations and additional paid-in capital within equity in its consolidated balance sheet for the year ended December 31, 2021.

### August 2021 Securities Purchase Agreement

In August 2021, the Company entered into a Securities Purchase Agreement (the “August 2021 Securities Purchase Agreement”) with an institutional investor, pursuant to which the Company agreed to offer, issue and sell to this investor, in a registered direct offering, 1,300,000 shares of its Common Stock, pre-funded warrants to purchase up to an aggregate of 3,647,556 shares of Common Stock (the “Pre-Funded Warrants”), and warrants to purchase up to 2,473,778 shares of Common Stock (the “Warrants”). The combined purchase price of each share of Common Stock and accompanying Warrants is \$5.053 per share. The combined purchase price of each Pre-Funded Warrant and accompanying Warrant is \$5.052 (equal to the combined purchase price per share of Common Stock and accompanying Warrant, minus \$0.001). The Company received gross proceeds of approximately \$25.0 million, and after deducting the placement agent fees and expenses and offering costs, net proceeds were approximately \$22.6 million (see Note 8).

As a result of this registered direct offering price per share being less than the October 2020 and March 2021 registered direct offerings price per share, the Company was obligated to issue an additional 634,600 shares of unregistered Common Stock to the investors in the Company's October 2020 and March 2021 registered direct offerings pursuant to the anti-dilutive provisions of the October 2020 and March 2021 Securities Purchase Agreements. In August 2021, the Company issued 634,600 dividend shares to certain common stockholders with a fair value of approximately \$3.1 million, which the Company recorded as a credit to additional paid-in capital, and since the Company has an accumulated deficit, the corresponding debit to additional paid-in capital, resulting in no dollar impact within the Company's consolidated statement of changes in stockholders' equity (deficit) for the year ended December 31, 2021.

### **ATM Agreement**

In September 2019, the Company entered into a Common Stock Sales Agreement (the "ATM Agreement") with Cantor Fitzgerald & Co. ("Cantor") under which the Company may offer and sell, from time to time, at its sole discretion, shares of common stock having an aggregate offering price of up to \$25.0 million through Cantor as our sales agent. The Company's registration statement on Form S-3 contemplated under the ATM Agreement was declared effective by the SEC on September 5, 2019. The registration statement on Form S-3 includes a base prospectus covering the offering of up to \$100 million in aggregate shares of securities as defined within the prospectus and a prospectus supplement of up to a maximum aggregate offering of \$25 million in common stock in accordance with the ATM Agreement.

Cantor may sell common stock under the ATM Agreement by any method permitted by law deemed to be an "at the market offering" as defined in Rule 415 of the Securities Act of 1933, as amended (the "Securities Act"), including without limitation sales made by means of ordinary brokers' transactions on the Nasdaq Global Market or otherwise at market prices prevailing at the time of sale, in block transactions, or as otherwise directed by the Company. Cantor will use commercially reasonable efforts to sell the common stock from time to time, based upon instructions from the Company (including any price, time or size limits or other customary parameters or conditions the Company may impose). The Company will pay Cantor a commission of up to three percent (3.0%) of the gross sales proceeds of any common stock sold through Cantor under the ATM Agreement, and also has provided Cantor with customary indemnification rights.

The Company is not obligated to make any sales of common stock under the ATM Agreement. The offering of shares of common stock pursuant to the ATM Agreement will terminate upon the earlier of (i) the sale of all common stock subject to the ATM Agreement, or (ii) termination of the ATM Agreement in accordance with its terms.

As a result of the limitations of General Instruction I.B.6 of Form S-3, and in accordance with the terms of the ATM Agreement, the Company filed a prospectus supplement on May 14, 2020 that registered the offer and sale of shares of its common stock having an aggregate offering price of up to \$22.0 million from time to time through Cantor. During the year ended December 31, 2021, the Company had not sold any shares of common stock under the ATM Agreement. During the year ended December 31, 2020, the Company had sold 7,883 shares of common stock under the ATM Agreement for gross proceeds of approximately \$64,000, and after deducting commissions, net proceeds were approximately \$62,000.

On January 10, 2022, the Company notified Cantor of its intent to terminate, which became effective on January 18, 2022, the Controlled Equity Offering Sales Agreement dated as of September 3, 2019 between the Company and Cantor in connection with the Company's at-the-market offering of up to \$25.0 million.

On January 19, 2022, the Company entered into an At-the-Market Sales Agreement ("Sales Agreement") with Virtu Americas LLC ("Virtu"), as sales agent. Pursuant to the terms of the Sales Agreement, the Company may issue and sell from time to time shares of its common stock, par value \$0.0001 per share, through Virtu, acting as its sales agent, or directly to Virtu, acting as principal. Pursuant to the Company's prospectus supplement filed on January 19, 2022, the Company may issue and sell shares of its common stock having an aggregate offering price of up to \$25.0 million.

Under the Sales Agreement, Shares will be offered and sold pursuant to the Company's shelf registration statement on Form S-3 (File No. 333-233601) filed with the Securities and Exchange Commission (the "SEC") on September 3, 2019, declared effective by the SEC on September 5, 2019. In addition, under the Sales Agreement, sales of Shares may be made by any method permitted by law deemed to be an "at the market offering" as defined in Rule 415(a)(4) under the Securities Act of 1933, as amended.

The Company will pay Virtu a commission rate of up to 3.0% of the gross proceeds from each sale of Shares and has agreed to provide Virtu with customary indemnification and contribution rights. The Company will also reimburse Virtu for certain specified expenses in connection with entering into the Sales Agreement. The Company has no obligation to sell any of the Shares under the Sales Agreement and may at any time suspend the offering of its common stock upon notice and subject to other conditions. The Sales Agreement contains customary representations, warranties and agreements by the Company, other obligations of the parties and termination provisions.

The Company intends to use the net proceeds from the sale of any Shares sold under the Sales Agreement for general corporate purposes, which may include, among other things, increasing the Company's working capital, financing ongoing operating expenses and overhead, funding capital expenditures, repayment of debt, acquisitions, and investments in the Company's subsidiaries.

#### **Securities Purchase Agreement**

In October 2020, the Company entered into the October 2020 Purchase Agreement with certain institutional investors (the "Purchasers"), pursuant to which the Company agreed to offer, issue and sell to the Purchasers, (i) in a registered direct offering, an aggregate of 1,134,470 shares of common stock, par value \$0.0001 per share and (ii) in a concurrent private placement, Series A warrants and Series B warrants to purchase up to an aggregate 567,234 shares of Common Stock, for aggregate gross proceeds to the Company of approximately \$8.5 million, and after deducting commissions and offering costs, net proceeds were approximately \$7.8 million (see Note 8). In October 2020, the Company paid Arcadia Securities, LLC a fee equal to 3.5% of the aggregate purchase price of the shares of its common stock sold in the offering to certain of the investors. In addition, in October 2020, the Company paid Cantor a fee equal to 3.5% of the aggregate purchase price of the shares of its common stock sold in the offering.

#### **10. Stock-Based Compensation**

##### **Equity Incentive Plan**

In May 2014, the Company adopted and the shareholders approved the 2014 Equity Incentive Plan (the 2014 Plan). Under the 2014 Plan, 233,722 shares of the Company's common stock were initially reserved for the issuance of stock options to employees, directors, and consultants, under terms and provisions established by the Board of Directors. Under the terms of the 2014 Plan, options may be granted at an exercise price not less than fair market value. For employees holding more than 10% of the voting rights of all classes of stock, the exercise prices for incentive stock options may not be less than 110% of fair market value, as determined by the Board of Directors. The terms of options granted under the 2014 Plan may not exceed ten years.

In June 2020, the adoption of an amendment to the 2014 Plan to eliminate the evergreen provision and set the number of shares of common stock reserved for issuance thereunder to 2,183,692 shares was approved by the Company's stockholders. The additional shares reserved in the below stock option activity table includes 162,736 shares reserved pursuant to the evergreen provision and 400,000 shares reserved pursuant to the amendment to the 2014 Plan.

##### **Stock Options**

The number of shares, terms, and vesting periods are determined by the Company's Board of Directors or a committee thereof on an option by option basis. Options generally vest ratably over service periods of up to four years and expire ten years from the date of grant.



Stock option activity for the year ended December 31, 2021 is represented in the following table:

	Shares Available for Grant	Options Outstanding	
		Number of Shares	Weighted-Average Exercise Price
<b>Balances at December 31, 2020</b>	584,161	1,550,956	\$ 9.43
Options granted	(493,440)	493,440	\$ 5.04
Options exercised	—	(1,559)	\$ 2.89
Options cancelled	137,378	(137,378)	\$ 7.05
<b>Balances at December 31, 2021</b>	<u>228,099</u>	<u>1,905,459</u>	<u>\$ 8.47</u>

Additional information related to the status of options as of December 31, 2021 is summarized as follows:

	Number of Options	Weighted-Average Exercise Price	Weighted-Average Contractual Term (Years)	Aggregate Intrinsic Value (in thousands)
Options outstanding	1,905,459	\$ 8.47	6.97	\$ 13
Options vested and exercisable	1,287,094	\$ 9.70	6.11	\$ —

The Company estimated the fair value of options using the BSM option valuation model. The fair value of options is being amortized on a straight-line basis over the requisite service period of the awards. The fair value of the options granted during the years ended December 31, 2021 and 2020 were estimated using the following assumptions:

	Years Ended December 31,	
	2021	2020
Expected term (in years)	6.00	6.00
Expected volatility	99% - 100%	84% - 100%
Risk-free interest rate	0.8% - 1.17%	0.38% - 1.73%
Dividend yield	0%	0%

During the years ended December 31, 2021 and 2020, the Company granted options to purchase 493,440 and 207,155 shares with a weighted-average grant date fair value of \$3.68 and \$4.72 per share, respectively.

There were 1,559 and 4,913 options exercised during the years ended December 31, 2021 and 2020, respectively. The aggregate intrinsic value of options exercised during the years ended December 31, 2021 and 2020 was approximately \$5,000 and \$17,000, respectively.

### Stock-Based Compensation

The following table presents stock-based compensation expense related to stock options (in thousands):

	Years Ended December 31,	
	2021	2020
Research and development	\$ 687	\$ 590
General and administrative	1,564	1,538
<b>Total</b>	<u>\$ 2,251</u>	<u>\$ 2,128</u>

As of December 31, 2021, total unrecognized stock-based compensation expenses related to unvested stock options was approximately \$2.5 million, which is expected to be recognized on a straight-line basis over a weighted-average period of approximately 2.42 years.

## 11. Income Taxes

The Company has accumulated net losses since inception and has not recorded an income tax provision or benefit during the years ended December 31, 2021 and 2020.

A reconciliation between the statutory U.S. federal rate and the Company's effective tax rate is as follows (in thousands):

	Year Ended December 31,	
	2021	2020
Federal income tax at statutory rate	\$ (8,860)	\$ (4,690)
State income tax, net of federal benefit	(759)	(36)
Foreign tax differential	1,345	1,906
State Rate change	(346)	287
Permanent differences	66	1,088
Tax credits generated in current year	(894)	(649)
Uncertain tax position change	224	162
Other	28	(92)
Valuation allowance change	9,196	2,024
	<u>\$ —</u>	<u>\$ —</u>

Deferred income taxes reflect the net tax effects of temporary differences between the carrying amounts of assets and liabilities for financial reporting purposes and the amounts used for income tax purposes. Significant components of our Net deferred tax assets (in thousands) are as follows:

	Year Ended December 31,	
	2021	2020
Net operating loss carryforwards	\$ 22,603	\$ 14,793
Accruals and reserves	175	39
Stock based compensations	1,607	1,153
Research and development credits	2,692	2,021
Deferred revenue	1,454	1,338
Depreciation and amortization	—	(9)
Total	28,531	19,335
Valuation allowance change	(28,531)	(19,335)
Net deferred tax assets (liabilities)	<u>\$ —</u>	<u>\$ —</u>

A reconciliation of the beginning and ending amount of the Company's liability for uncertain tax positions (in thousands) is as follows:

	December 31,	
	2021	2020
Balance at the beginning of the year	\$ 705	\$ 534
Increase/(decrease) based on current year tax positions	235	171
Increase/(decrease) for prior year tax positions	—	—
Balance at the end of the year	<u>\$ 940</u>	<u>\$ 705</u>

Due to the existence of the valuation allowance, future changes in the Company's liability for uncertain tax positions will not impact the Company's effective tax rate. The Company does not anticipate that there will be a substantial change in its liability for uncertain tax positions in the next twelve months.

Tax Legislation subjects a U.S. shareholder to tax on Global Intangible Low-Taxed Income ("GILTI") earned by certain foreign subsidiaries. The FASB Staff Q&A, Topic 740, No. 5, Accounting for Global Intangible Low-Taxed Income, states that an entity can make an accounting policy election to either recognize deferred taxes for temporary basis differences expected to reverse as GILTI in

future years or to provide for the tax expense related to GILTI in the year the tax is incurred as a period expense only. The Company has elected to account for GILTI in the year the tax is incurred. The Company does not have a GILTI inclusion as the foreign subsidiaries are in loss positions in 2021.

Based on the available objective evidence, management believes it is more-likely-than-not that the deferred tax assets were not fully realizable as of December 31, 2021 and 2020. Accordingly, the Company has established a full valuation allowance against its deferred tax assets. The net change in the valuation allowance for the years ended December 31, 2021 and 2020 was approximately \$9.2 million and \$2.0 million, respectively.

At December 31, 2021, the Company had federal net operating loss carryforwards of approximately \$19.5 million that begin to expire in 2034. The Company also has federal net operating losses of approximately \$66.5 million that arose after the 2017 tax year and will carryforward indefinitely. The Company has state net operating loss carryforwards of approximately \$69.2 million that will begin to expire in 2034. At December 31, 2021, the Company has research credit carryforwards of approximately \$2.9 million and approximately \$814,000 for federal and California state income tax purposes, respectively. The federal credits begin to expire in 2034 and the state credits can be carried forward indefinitely.

Under the Internal Revenue Code (“IRC”) Sections 382 and 383, annual use of the Company’s net operating loss and research tax credit carryforwards to offset taxable income may be limited based on cumulative changes in ownership. The Company has not completed an analysis to determine whether any such limitations have been triggered as of December 31, 2021. The Company has no income tax affect due to the recognition of a full valuation allowance on the expected tax benefits of future loss carry forwards based on uncertainty surrounding realization of such assets. Any annual limitation may result in the expiration of net operating losses and credits before utilization. The Company may continue to experience ownership changes in the future as a result of the Company’s future expected equity financings and subsequent shifts in its stock ownership, some of which may be outside of its control.

The Company is subject to taxation in the United States, California, the Netherlands and China, and remains subject to possible examination by tax authorities in these jurisdictions for tax years dating back to 2014. The Company became subject to taxation in Maryland and North Carolina starting tax year 2020 , and becomes subject to taxation in Colorado, Pennsylvania and South Carolina starting tax year 2021. The Company does not have any pending tax examinations. Following the Company’s adoption of ASC 740-10 regarding accounting for uncertainty in income taxes, the Company made a comprehensive review of its portfolio of uncertain tax positions in accordance with the guidance. In this regard, an uncertain tax position represents the Company’s expected treatment of a tax position taken in a filed tax return, or planned to be taken in a future tax return, that has not been reflected in measuring income tax expense for financial reporting purposes. As a result of that review, the Company concluded there were no uncertain tax positions and no cumulative effect on retained earnings at the time of adoption.

## **12. Related Parties**

### **Joint Venture**

On February 11, 2018, the Company entered into a Joint Venture (“JV”) Agreement with Hepalink which is a related party and principal shareholder in the Company, pursuant to which the Company formed a JV Entity for developing and commercializing products for infectious diseases in the greater China territories. It was agreed by the parties that the Company shall be reimbursed for certain legal and contract manufacturing expenses related to the clinical drug supply for a Phase 3 clinical study of AR-301 and the clinical drug supply for a clinical study of AR-105. For the years ended December 31, 2021 and 2020, the Company recorded approximately \$75,000 and \$188,000, respectively, as a reduction to operating expenses in the consolidated statements of operations for amounts reimbursed to the Company by the JV Entity under this arrangement. As of December 31, 2021 and 2020, the Company recorded approximately \$43,000 and \$3,000, respectively, in other receivables on the consolidated balance sheets for amounts owed to the Company by the JV Entity under this arrangement and the Company expects the amounts to be collectable and as a result, no reserve for uncollectability was established.

### **Serum International B.V.**

In July 2019, the Company issued 801,820 shares of its restricted common stock in a private placement to Serum International B.V. (“SIBV”), an affiliate of Serum Institute of India Private Limited, for total gross proceeds of \$10 million (see Note 9). As a result of this transaction, SIBV and its affiliates, are considered related parties to the Company. In September 2019, the Company and Serum

AMR Products (“SAMR”), a party under common ownership of SIBV, entered into a License, Development and Commercialization Agreement (“ License Agreement”) (see Note 6).

The Company determined that no performance obligations were satisfied as of December 31, 2021 and 2020. Therefore, no revenue related to the License Agreement was recognized during the years ended December 31, 2021 and 2020. The Company has recorded contract liabilities resulting from the License Agreement of approximately \$18.7 million and \$18.7 million to deferred revenue, current, and approximately \$913,000 and \$854,000 to deferred revenue, noncurrent, on its consolidated balance sheets at December 31, 2021 and 2020, respectively. The Company capitalized a contract asset resulting from the License Agreement of approximately \$2.1 million related to the incremental costs of obtaining the License Agreement on its consolidated balance sheets, of which approximately \$2.0 million and \$2.0 million is classified as current, and approximately \$96,000 and \$90,000 is classified as noncurrent, as of December 31, 2021 and 2020, respectively.

### 13. Commitments and Contingencies

#### Facility Lease

The Company previously leased office and lab space in San Jose, California under an operating lease arrangement which terminated in December 2020.

In October 2020, the Company entered into a new lease agreement (the “Lease Agreement”) with Boccardo Corporation (the “Landlord”) pursuant to which the Company leased approximately 15,129 square feet of office and laboratory space in Los Gatos, California. In December 2020, the Company moved into the new facility which serves as the Company’s corporate headquarters and the Company has made leasehold improvements to the new facility of which approximately \$378,000 may be reimbursed by the Landlord as certain criteria are met as defined in the Lease Agreement. The lease commenced in December 2020 and has an approximate five year term with a three year renewal option. Rental payments by the Company commenced on February 1, 2021. In connection with the Lease Agreement, the Company was required to deliver a security deposit in the form of a letter of credit of \$500,000 to the Landlord which is classified as restricted cash, noncurrent, in the Company’s consolidated balance sheet.

The future minimum lease payments for the new facility as of December 31, 2021 are as follows (in thousands):

<u>Year ending December 31,</u>	
2022	\$ 610
2023	628
2024	646
2025	666
2026	57
Total	<u>\$ 2,607</u>

Rent expense for leases was approximately \$630,000 and \$529,000 for the years ended December 31, 2021 and 2020, respectively.

#### Indemnification

In the normal course of business, the Company enters into contracts and agreements that contain a variety of representations and warranties and provide for general indemnifications. The Company’s exposure under these agreements is unknown because it involves claims that may be made against the Company in the future but have not yet been made. To date, the Company has not paid any claims or been required to defend any action related to its indemnification obligations. However, the Company may incur charges in the future as a result of these indemnification obligations.

#### License Agreements

The Company has entered into various collaboration and licensing agreements that provide it with access to certain technology and patent rights. Under the terms of the agreements, the Company may be required to make milestone payments upon achievement of certain development and regulatory activities. See further disclosure related to these agreements in Note 4.

## **Contingencies**

From time to time, the Company may have certain contingent liabilities that arise in the ordinary course of its business activities. The Company accrues a liability for such matters when it is probable that a potential loss will be incurred and such amount can be reasonably estimated. As of December 31, 2021 and 2020, no accruals have been made related to contingencies.

From time to time, the Company may be involved in various legal proceedings, claims and litigation arising in the ordinary course of business. See below Legal Proceedings for legal complaints filed during the years ended December 31, 2021 and 2020.

## **Legal Proceedings**

A complaint was filed in February 2020 in the New York State Supreme Court against the Company by an investor who invested in the Company's preferred stock in July 2017 prior to the Company's IPO in August 2018. The complaint alleges, among other things, that the Company breached its contract and fiduciary duty, by not issuing additional securities to the investor as a result of the Company's IPO. The plaintiff is asking for approximately \$277,000 in compensatory damages. The parties are currently in fact discovery. The Company believes that the claims in this complaint are without merit and intends to defend vigorously against them. The Company accrues a liability for such matters when it is probable that future expenditures will be made, and such expenditures can be reasonably estimated. As of December 31, 2021 and 2020, no liability recognized related to this matter.

In September 2021, Cantor filed a complaint in the New York State Supreme Court against the Company alleging that it breached a letter agreement with Cantor and owes Cantor approximately \$1.8 million, including attorney's fees for a financing fee related to the Company's equity offering in August 2021. The parties entered into a settlement agreement and release on December 15, 2021. The settlement amount is included in accounts payable on the consolidated balance sheet as of December 31, 2021.

The Company submitted a complaint in Superior Court of the State of California, County of Santa Clara, against its former landlord on October 22, 2021, asserting claims for breach of contract, breach of the covenant of good faith and fair dealing, unjust enrichment and violation of the unfair competition law. The claims arise from rent increases and the termination of the tenancy the Company allege were not permitted by the agreement with the landlord. The Company seeks to recover rent paid under protest, its deposit, moving and relocation expenses and consequential damages arising from disruption to its operations. The Company will account for any possible gain that may result from this complaint upon resolution.

## **Grant Income**

The Company receives various grants that are subject to audit by the grantors or their representatives. Such audits could result in requests for reimbursement for expenditures disallowed under the terms of the grant; however, management believes that these disallowances, if any, would be immaterial.

## **Cystic Fibrosis Foundation Agreement**

In December 2016, the Company received an award for up to \$2.9 million from the CFF to advance research on potential drugs utilizing inhaled gallium citrate anti-infective. In November 2018, the CFF increased the award to \$7.5 million. Under the award agreement, the CFF will make payments to the Company as certain milestones are met. The award agreement also contains a provision whereby if the Company spends less on developing a potential drug utilizing inhaled gallium citrate anti-infective than the Company actually receives under this award agreement, the Company will be required to return the excess portion of the award to the CFF. At the end of any reporting period, if the Company determines that the cumulative amount spent on this program is less than the cumulative cash received from the CFF, the Company will record the excess amount received as a liability. No liability related to this excess amount was recorded by the Company as of December 31, 2021 and 2020.

In the event that development efforts are successful and the Company commercializes a drug from these related development efforts, the Company will be subject to paying to CFF a one-time amount over time equal to nine times the actual net award received from CFF. Such amount shall be paid in not more than five annual installments, as follows: within ninety days of the end of the calendar year in which the first commercial sale occurs, and within ninety days of the end of each subsequent calendar year until the net amount received from CFF is repaid. The Company shall pay 15% of net sales for that calendar year up to the amount of the net award received

from CFF (except that in the fifth installment, if any, the Company shall pay the remaining unpaid portion of the net award received from CFF).

In the event that the Company licenses rights to the product in the field to a third-party, sells the product, or consummates a change of control transaction prior to the first commercial sale, the Company shall pay to CFF an amount equal to 15% of the amounts received by the Company and its shareholders in connection with such disposition (whether paid upfront or in accordance with subsequent milestones and whether paid in cash or property) up to nine times the actual net award received from CFF. The payment shall be made within sixty days after the closing of such a transaction.

In the event that the development efforts are delayed, which result from events within the Company's control, for more than one hundred eighty (180) consecutive days at any time before the first commercialization of the drug from the related development efforts, the CFF may provide an interruption notice to the Company, or in lieu of the interruption license, pay to the CFF an amount greater than two times the award received plus interest up to the time of such election. The Company then has thirty (30) days to respond to such notice. If the Company does not respond within thirty (30) days, an interruption license shall be effective. The interruption license to the CFF is an exclusive, worldwide license under the development program technology to manufacture, have manufactured, license, use, sell, offer to sell, and support the product in the field and includes financial conditions for both parties.

None of these events have occurred as of December 31, 2021.

#### **Kermode Agreement**

In February 2021, the Company entered into the Kermode Agreement, in which the Company received an upfront payment. Since then one milestone payment has been received in December 2021. The Company will receive additional milestone payments from Kermode as certain phases defined in the agreement are completed. The Company is also entitled to additional payments from Kermode for royalty payments on future net sales (see Note 6). In the event that the research and development efforts under the agreement are successful and if the Company elects to develop and commercialize products under certain provisions contained in the agreement, the Company shall pay to Kermode a 5% royalty of net sales from those products. None of these events occurred as of December 31, 2021.

#### **MedImmune Limited License Agreement**

In July 2021, the Company executed the MedImmune License Agreement (see Note 4). As additional consideration under this agreement, the Company will pay MedImmune milestone payments upon the achievement of certain regulatory approvals, for one licensed product, up to a total aggregate amount of \$30.0 million and sales related milestone payments of up to \$85.0 million. There are no development milestone payments. MedImmune is entitled to royalty payments based on aggregate net sales ranging from 12.5% to 15% dependent on net sales volume. Further, until delivery of an interim data readout, or an interim futility analysis, from the first Phase 3 clinical study for any indication, MedImmune has a right of first negotiation regarding any commercial rights that the Company intends to sub-license. None of these events occurred as of December 31, 2021.

#### **14. Subsequent Events**

##### **ATM Agreement**

On January 10, 2022, the Company notified Cantor of its intent to terminate, which became effective on January 18, 2022, the Controlled Equity Offering Sales Agreement dated as of September 3, 2019 between the Company and Cantor in connection with the Company's at-the-market offering of up to \$25.0 million.

On January 19, 2022, the Company entered into an At-the-Market Sales Agreement ("Sales Agreement") with Virtu Americas LLC ("Virtu"), as sales agent. Pursuant to the terms of the Sales Agreement, the Company may issue and sell from time to time shares of its common stock, par value \$0.0001 per share, through Virtu, acting as its sales agent, or directly to Virtu, acting as principal. Pursuant to the Company's prospectus supplement filed on January 19, 2022, the Company may issue and sell shares of its common stock having an aggregate offering price of up to \$25.0 million.

The Company will pay Virtu a commission rate of up to 3.0% of the gross proceeds from each sale of Shares and has agreed to provide Virtu with customary indemnification and contribution rights. The Company will also reimburse Virtu for certain specified expenses in connection with entering into the Sales Agreement.

**Legal proceedings**

The Company submitted an amended complaint in Superior Court of the State of California, County of Santa Clara, against our former landlord on February 4, 2022, asserting claims for breach of contract, breach of the covenant of good faith and fair dealing, wrongful eviction/constructive eviction and unjust enrichment and violation of the unfair competition law. The claims arise from rent increases and the termination of the tenancy that we allege were not permitted by the agreement with the landlord. We seek to recover rent paid under protest, our deposit, moving and relocation expenses and consequential damages arising from disruption to our operations. The landlord has filed a cross-complaint for damage to property and attorneys' fees.

**Note Purchase Agreement**

Pursuant to the terms agreed in the Note Purchase Agreement with Streeterville Capital, LLC, the Company issued a second Note to the Lender on February 21, 2022 in the aggregate principal amount of \$5,250,000 which are substantially similar to the first Note except the maturity date is February 21, 2024.

## List of Subsidiaries of Aridis Pharmaceuticals, Inc.:

<b>Name</b>	<b>Jurisdiction of Incorporation/Formation</b>
Aridis Biopharmaceuticals LLC	Delaware
Aridis Pharmaceuticals C.V.	Netherlands

---



**CONSENT OF INDEPENDENT REGISTERED PUBLIC ACCOUNTING FIRM**

We consent to the incorporation by reference in Registration Statement Nos. 333-240131, 333-237611 and 333-233603 on Form S-8 and Nos. 333-233601 and 333-258809 on Form S-3 of our report dated April 13, 2022 (which report includes an explanatory paragraph regarding the existence of substantial doubt about the Company's ability to continue as a going concern), relating to the consolidated financial statements of Aridis Pharmaceuticals, Inc. as of and for the years ended December 31, 2021 and 2020, included in this Annual Report on Form 10-K for the year ended December 31, 2021.

/s/ Mayer Hoffman McCann P.C.

San Diego, California

April 13, 2022

---

**CERTIFICATION PURSUANT TO  
SECTION 13(a) OR 15(d) OF THE SECURITIES EXCHANGE ACT OF 1934  
AS ADOPTED PURSUANT TO  
SECTION 302 OF THE SARBANES-OXLEY ACT OF 2002**

I, Vu Truong, Ph.D., certify that:

1. I have reviewed this Annual Report on Form 10-K of Aridis Pharmaceuticals, Inc.;
2. Based on my knowledge, this report does not contain any untrue statement of a material fact or omit to state a material fact necessary to make the statements made, in light of the circumstances under which such statements were made, not misleading with respect to the period covered by this report;
3. Based on my knowledge, the consolidated financial statements, and other financial information included in this report, fairly present in all material respects the financial condition, results of operations and cash flows of the registrant as of, and for, the periods presented in this report;
4. The registrant's other certifying officer and I are responsible for establishing and maintaining disclosure controls and procedures (as defined in Exchange Act Rules 13a-15(e) and 15d-15(e)) and internal control over financial reporting (as defined in Exchange Act Rules 13a-15(f) and 15d-15(f)) for the registrant and have:
  - a) Designed such disclosure controls and procedures, or caused such disclosure controls and procedures to be designed under our supervision, to ensure that material information relating to the registrant, including its consolidated subsidiaries, is made known to us by others within those entities, particularly during the period in which this report is being prepared;
  - b) Designed such internal control over financial reporting, or caused such internal control over financial reporting to be designed under our supervision, to provide reasonable assurance regarding the reliability of financial reporting and the preparation of financial statements for external purposes in accordance with generally accepted accounting principles;
  - c) Evaluated the effectiveness of the registrant's disclosure controls and procedures and presented in this report our conclusions about the effectiveness of the disclosure controls and procedures, as of the end of the period covered by this report based on such evaluation; and
  - d) Disclosed in this report any change in the registrant's internal control over financial reporting that occurred during the registrant's most recent fiscal quarter (the registrant's fourth fiscal quarter in the case of an annual report) that has materially affected, or is reasonably likely to materially affect, the registrant's internal control over financial reporting; and
5. The registrant's other certifying officer and I have disclosed, based on our most recent evaluation of internal control over financial reporting, to the registrant's auditors and the audit committee of the registrant's board of directors (or persons performing the equivalent functions):
  - a) All significant deficiencies and material weaknesses in the design or operation of internal control over financial reporting which are reasonably likely to adversely affect the registrant's ability to record, process, summarize and report financial information; and
  - b) Any fraud, whether or not material, that involves management or other employees who have a significant role in the registrant's internal control over financial reporting.

Date: April 13, 2022

By: /s/ VU TRUONG

Vu Truong, Ph.D.  
*Chief Executive Officer*  
*(Principal Executive Officer)*

---

**CERTIFICATION PURSUANT TO  
SECTION 13(a) OR 15(d) OF THE SECURITIES EXCHANGE ACT OF 1934  
AS ADOPTED PURSUANT TO  
SECTION 302 OF THE SARBANES-OXLEY ACT OF 2002**

I, Fred Kurland, certify that:

1. I have reviewed this Annual Report on Form 10-K of Aridis Pharmaceuticals, Inc.;
2. Based on my knowledge, this report does not contain any untrue statement of a material fact or omit to state a material fact necessary to make the statements made, in light of the circumstances under which such statements were made, not misleading with respect to the period covered by this report;
3. Based on my knowledge, the consolidated financial statements, and other financial information included in this report, fairly present in all material respects the financial condition, results of operations and cash flows of the registrant as of, and for, the periods presented in this report;
4. The registrant's other certifying officer and I are responsible for establishing and maintaining disclosure controls and procedures (as defined in Exchange Act Rules 13a-15(e) and 15d-15(e)) and internal control over financial reporting (as defined in Exchange Act Rules 13a-15(f) and 15d-15(f)) for the registrant and have:
  - a) Designed such disclosure controls and procedures, or caused such disclosure controls and procedures to be designed under our supervision, to ensure that material information relating to the registrant, including its consolidated subsidiaries, is made known to us by others within those entities, particularly during the period in which this report is being prepared;
  - b) Designed such internal control over financial reporting, or caused such internal control over financial reporting to be designed under our supervision, to provide reasonable assurance regarding the reliability of financial reporting and the preparation of financial statements for external purposes in accordance with generally accepted accounting principles;
  - c) Evaluated the effectiveness of the registrant's disclosure controls and procedures and presented in this report our conclusions about the effectiveness of the disclosure controls and procedures, as of the end of the period covered by this report based on such evaluation; and
  - d) Disclosed in this report any change in the registrant's internal control over financial reporting that occurred during the registrant's most recent fiscal quarter (the registrant's fourth fiscal quarter in the case of an annual report) that has materially affected, or is reasonably likely to materially affect, the registrant's internal control over financial reporting; and
5. The registrant's other certifying officer and I have disclosed, based on our most recent evaluation of internal control over financial reporting, to the registrant's auditors and the audit committee of the registrant's board of directors (or persons performing the equivalent functions):
  - a) All significant deficiencies and material weaknesses in the design or operation of internal control over financial reporting which are reasonably likely to adversely affect the registrant's ability to record, process, summarize and report financial information; and
  - b) Any fraud, whether or not material, that involves management or other employees who have a significant role in the registrant's internal control over financial reporting.

Date: April 13, 2022

By: /s/ FRED KURLAND

Fred Kurland  
*Chief Financial Officer*  
*(Principal Financial Officer)*

---

**CERTIFICATION PURSUANT TO 18 U.S.C. SECTION 1350,  
AS ADOPTED PURSUANT TO  
SECTION 906 OF THE SARBANES-OXLEY ACT OF 2002**

In connection with the Annual Report on Form 10-K of Aridis Pharmaceuticals, Inc. (the “Company”) for the period ended December 31, 2021 as filed with the Securities and Exchange Commission on the date hereof (the “Report”), the undersigned, Vu Truong, Chief Executive Officer of the Company, hereby certifies, pursuant to 18 U.S.C. Section 1350, as adopted pursuant to Section 906 of the Sarbanes-Oxley Act of 2002, that to the best of his knowledge:

(1) the Report fully complies with the requirements of Section 13(a) or 15(d) of the Securities Exchange Act of 1934; and

(2) the information contained in the Report fairly presents, in all material respects, the financial condition and results of operations of the Company.

Date: April 13, 2022

By: /s/ VU TRUONG

\_\_\_\_\_  
Vu Truong, Ph.D.  
*Chief Executive Officer*  
*(Principal Executive Officer)*

---

**CERTIFICATION PURSUANT TO 18 U.S.C. SECTION 1350,  
AS ADOPTED PURSUANT TO  
SECTION 906 OF THE SARBANES-OXLEY ACT OF 2002**

In connection with the Annual Report on Form 10-K of Aridis Pharmaceuticals, Inc. (the “Company”) for the period ended December 31, 2021 as filed with the Securities and Exchange Commission on the date hereof (the “Report”), the undersigned, Fred Kurland, Chief Financial Officer of the Company, hereby certifies, pursuant to 18 U.S.C. Section 1350, as adopted pursuant to Section 906 of the Sarbanes-Oxley Act of 2002, that to the best of his knowledge:

- (1) the Report fully complies with the requirements of Section 13(a) or 15(d) of the Securities Exchange Act of 1934; and
- (2) the information contained in the Report fairly presents, in all material respects, the financial condition and results of operations of the Company.

Date: April 13, 2022

By: /s/ FRED KURLAND

---

Fred Kurland  
*Chief Financial Officer*  
*(Principal Financial Officer)*

---