



VALHI

2008

ANNUAL REPORT

VALHI, INC. CORPORATE AND OTHER INFORMATION

Board of Directors

Thomas E. Barry (b) (c)
Vice President
Southern Methodist University

Norman S. Edelcup (b) (c)
Mayor
Sunny Isles Beach, Florida

W. Hayden McIlroy (b)
Private Investor

Glenn R. Simmons (a)
Vice Chairman

Harold C. Simmons (a)
Chairman

J. Walter Tucker, Jr.
President
Tucker & Branham, Inc.

Steven L. Watson (a)
President and Chief Executive Officer

Board Committees

(a) *Executive Committee*

(b) *Audit Committee*

(c) *Management Development and Compensation Committee*

Corporate Officers

Harold C. Simmons
Chairman

Glenn R. Simmons
Vice Chairman

Steven L. Watson
President and Chief Executive Officer

William J. Lindquist
Senior Vice President

Bobby D. O'Brien
Vice President and Chief Financial Officer

Gregory M. Swalwell
Vice President and Controller

J. Mark Hollingsworth
Vice President and General Counsel

Kelly D. Luttmr
Vice President and Tax Director

John A. St.Wrba
Vice President and Treasurer

Robert D. Graham
Vice President

A. Andrew R. Louis
Secretary and Associate General Counsel

Operating Management of Subsidiaries

Kronos Worldwide, Inc.
Harold C. Simmons
Chairman

Steven L. Watson
Vice Chairman and Chief Executive Officer

NL Industries, Inc.
Harold C. Simmons
Chairman and Chief Executive Officer

CompX International Inc.
Glenn R. Simmons
Chairman

David A. Bowers
Vice Chairman, President and Chief Executive Officer

Waste Control Specialists LLC
Harold C. Simmons
Chairman

William J. Lindquist
Chief Executive Officer

Rodney A. Baltzer
President

Stock and Bond Exchanges

Valhi's common shares are listed on the New York Stock Exchange under the symbol "VHI."

Kronos' common shares are listed on the New York Stock Exchange under the symbol "KRO."

NL's common shares are listed on the New York Stock Exchange under the symbol "NL."

CompX's Class A common shares are listed on the New York Stock Exchange under the symbol "CIX."

Kronos International's 6.5% Senior Secured Notes Due 2013 are listed on the Luxembourg Stock Exchange and are quoted in the over-the-counter market in the U.S.

Annual Meeting

The 2009 Annual Meeting of Stockholders will be held at the office of the Company, Three Lincoln Centre, 5430 LBJ Freeway, Suite 1700, Dallas, Texas 75240-2697, on the date and time as set forth in the notice of the meeting, proxy statement and form of proxy that will be mailed to stockholders in advance of the meeting.

Form 10-K Report

The Company's Annual Report on Form 10-K for the year ended December 31, 2008, as filed with the Securities and Exchange Commission, is printed as part of this Annual Report. Additional copies are available without charge upon written request to:

A. Andrew R. Louis, Secretary
Valhi, Inc.
Three Lincoln Centre
5430 LBJ Freeway, Suite 1700
Dallas, Texas 75240-2697

Transfer Agent

Computershare Investor Services, L.L.C. acts as transfer agent, registrar and dividend paying agent for the Company's common stock. Communications regarding stockholder accounts, dividends and change of address should be directed to:

Computershare Investor Services, L.L.C.
P.O. Box 43036
Providence, RI 02940-3036
(312) 360-5239

Visit us on the Web
<http://www.valhi.net>

SECURITIES AND EXCHANGE COMMISSION
Washington, D.C. 20549

FORM 10-K

ANNUAL REPORT PURSUANT TO SECTION 13 OR 15(d) OF THE SECURITIES EXCHANGE
ACT OF 1934 - For the fiscal year ended December 31, 2008

Commission file number 1-5467

VALHI, INC.

(Exact name of Registrant as specified in its charter)

Delaware

(State or other jurisdiction of
Incorporation or organization)

87-0110150

(IRS Employer
Identification No.)

5430 LBJ Freeway, Suite 1700, Dallas, Texas

(Address of principal executive offices)

75240-2697

(Zip Code)

Registrant's telephone number, including area code: (972) 233-1700

Securities registered pursuant to Section 12(b) of the Act:

<u>Title of each class</u>	<u>Name of each exchange on which registered</u>
Common stock (\$.01 par value per share)	New York Stock Exchange

Securities registered pursuant to Section 12(g) of the Act:

None.

Indicate by check mark:

If the Registrant is a well-known seasoned issuer, as defined in Rule 405 of the Securities Act. Yes ___ No X

If the Registrant is not required to file reports pursuant to Section 13 or Section 15(d) of the Act. Yes ___ No X

Whether the Registrant (1) has filed all reports required to be filed by Section 13 or 15(d) of the Securities Exchange Act of 1934 during the preceding 12 months (or for such shorter period that the Registrant was required to file such reports), and (2) has been subject to such filing requirements for the past 90 days. Yes X No ___

If disclosure of delinquent filers pursuant to Item 405 of Regulation S-K is not contained herein, and will not be contained, to the best of Registrant's knowledge, in definitive proxy or information statements incorporated by reference in Part III of this Form 10-K or any amendment to this Form 10-K. Yes ___ No X

Whether the Registrant is a large accelerated filer, an accelerated filer or a non-accelerated filer or a smaller reporting company (as defined in Rule 12b-2 of the Act). Large accelerated filer ___ Accelerated filer X non-accelerated filer ___ smaller reporting company ___.

Whether the Registrant is a shell company (as defined in Rule 12b-2 of the Act). Yes ___ No X.

The aggregate market value of the 6.3 million shares of voting common stock held by nonaffiliates of Valhi, Inc. as of June 30, 2008 (the last business day of the Registrant's most recently-completed second fiscal quarter) approximated \$171.9 million.

As of February 27, 2009, 113,599,955 shares of the Registrant's common stock were outstanding.

Documents incorporated by reference

The information required by Part III is incorporated by reference from the Registrant's definitive proxy statement to be filed with the Commission pursuant to Regulation 14A not later than 120 days after the end of the fiscal year covered by this report.

Valhi, Inc.
(NYSE: VHI)
December 31, 2007

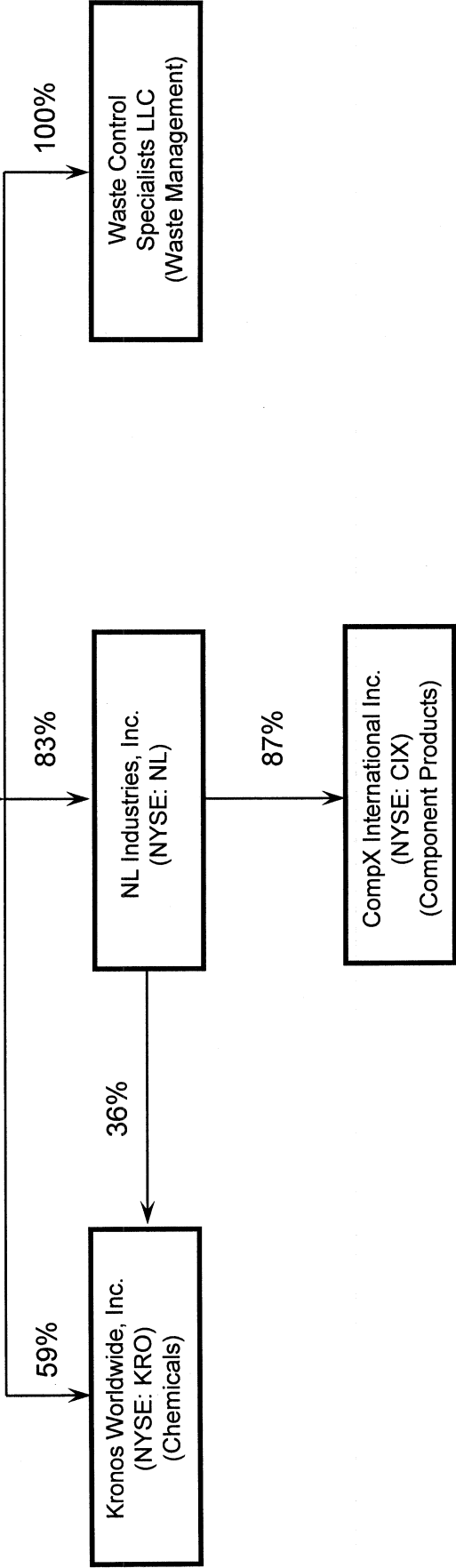

PART I

ITEM 1. BUSINESS

Valhi, Inc. (NYSE: VHI) is primarily a holding company. We operate through our wholly-owned and majority-owned subsidiaries, including NL Industries, Inc., Kronos Worldwide, Inc., CompX International Inc. and Waste Control Specialists LLC ("WCS"). Kronos (NYSE: KRO), NL (NYSE: NL) and CompX (NYSE: CIX) each file periodic reports with the U.S. Securities and Exchange Commission ("SEC").

Our principal executive offices are located at Three Lincoln Center, 5430 LBJ Freeway, Suite 1700, Dallas, Texas 75240. Our telephone number is (972) 233-1700. We maintain a worldwide website at www.valhi.net.

Brief History

LLC Corporation, our legal predecessor, was incorporated in Delaware in 1932. We are the successor company of the 1987 merger of LLC Corporation and another entity controlled by Contran Corporation. We are majority owned by subsidiaries of Contran, which own approximately 94% of our outstanding common stock at December 31, 2008. Substantially all of Contran's outstanding voting stock is held by trusts established for the benefit of certain children and grandchildren of Harold C. Simmons (for which Mr. Simmons is the sole trustee) or is held directly by Mr. Simmons or other persons or entities related to Mr. Simmons. Consequently, Mr. Simmons may be deemed to control Contran and us.

Key events in our history include:

- 1979 - Contran acquires control of LLC;
- 1981 - Contran acquires control of our other predecessor company;
- 1982 - Contran acquires control of Keystone Consolidated Industries, Inc., a predecessor to CompX;
- 1984 - Keystone spins-off an entity that includes what is to become CompX; this entity subsequently merges with LLC;
- 1986 - Contran acquires control of NL, which at the time owns 100% of Kronos and a 50% interest in Titanium Metal Corporation ("TIMET");
- 1987 - LLC and another Contran controlled company merge to form Valhi, our current corporate structure;
- 1988 - NL spins-off an entity that includes its investment in TIMET;
- 1995 - WCS begins start-up operations;
- 1996 - TIMET completes an initial public offering;
- 2003 - NL completes the spin-off of Kronos through the pro-rata distribution of Kronos shares to its shareholders including us;
- 2004 through 2005 - NL distributes Kronos shares to its shareholders, including us, through quarterly dividends;
- 2007 - We distribute all of our TIMET common stock to our shareholders through a stock dividend; and
- 2008 - WCS receives a license for the disposal of byproduct material and begins construction of the byproduct facility infrastructure.
- 2009 - WCS receives a license for the disposal of Class A, B and C low-level radioactive waste.

Unless otherwise indicated, references in this report to "we", "us" or "our" refer to Valhi, Inc. and its subsidiaries, taken as a whole.

Forward-Looking Statements

This Annual Report contains forward-looking statements within the meaning of the Private Securities Litigation Reform Act of 1995. Statements in this Annual Report on Form 10-K that are not historical in nature are forward-looking in nature about our future and are not statements of historical fact. Statements are found in this report including, but not limited to, statements found in Item 1 - "Business," Item 1A - "Risk Factors," Item 3 - "Legal Proceedings," Item 7 - "Management's Discussion and Analysis of Financial Condition and Results of Operations" and Item 7A - "Quantitative and Qualitative Disclosures About Market Risk," are forward-looking statements that represent our beliefs and assumptions based on currently available information. In some cases you can identify these forward-looking statements by the use of words such as "believes," "intends," "may," "should," "could," "anticipates," "expected" or comparable terminology, or by discussions of strategies or trends. Although we believe the expectations reflected in such forward-looking statements are reasonable, we do not know if these expectations will be correct. Forward-looking statements by their nature involve substantial risks and uncertainties that could significantly impact expected results. Actual future results could differ materially from those predicted. While it is not possible to identify all factors, we continue to face many risks and uncertainties. Among the factors that could cause actual future results to differ materially from those described herein are the risks and uncertainties discussed in this Annual Report and those described from time to time in our other filings with the SEC including, but not limited to, the following:

- Future supply and demand for our products;
- The cyclical nature of certain of our businesses (such as Kronos' TiO₂ operations);
- Customer inventory levels (such as the extent to which Kronos' customers may, from time to time, accelerate purchases of TiO₂ in advance of anticipated price increases or defer purchases of TiO₂ in advance of anticipated price decreases);
- Changes in our raw material and other operating costs (such as energy costs);
- General global economic and political conditions (such as changes in the level of gross domestic product in various regions of the world and the impact of such changes on demand for, among other things, TiO₂);
- Competitive products and substitute products;
- Possible disruption of our business or increases in the cost of doing business resulting from terrorist activities or global conflicts;
- Customer and competitor strategies;
- The impact of pricing and production decisions;
- Competitive technology positions;
- The introduction of trade barriers;
- Restructuring transactions involving us and our affiliates;
- Potential consolidation or solvency of our competitors;
- Demand for high performance marine components;
- The extent to which our subsidiaries were to become unable to pay us dividends;
- Uncertainties associated with new product development;
- Fluctuations in currency exchange rates (such as changes in the exchange rate between the U.S. dollar and each of the euro, the Norwegian krone, the Canadian dollar and the New Taiwan dollar);
- Operating interruptions (including, but not limited to, labor disputes, leaks, natural disasters, fires, explosions, unscheduled or unplanned downtime and transportation interruptions);
- The timing and amounts of insurance recoveries;

- Our ability to renew or refinance credit facilities;
- Our ability to maintain sufficient liquidity;
- The ultimate outcome of income tax audits, tax settlement initiatives or other tax matters;
- The ultimate ability to utilize income tax attributes or changes in income tax rates related to such attributes, the benefit of which has been recognized under the more likely than not recognition criteria (such as Kronos' ability to utilize its German net operating loss carryforwards);
- Environmental matters (such as those requiring compliance with emission and discharge standards for existing and new facilities, or new developments regarding environmental remediation at sites related to our former operations);
- Government laws and regulations and possible changes therein (such as changes in government regulations which might impose various obligations on present and former manufacturers of lead pigment and lead-based paint, including NL, with respect to asserted health concerns associated with the use of such products);
- The ultimate resolution of pending litigation (such as NL's lead pigment litigation and litigation surrounding environmental matters of NL and Tremont);
- Our ability to comply with covenants contained in our revolving bank credit facilities; and
- Possible future litigation.

Should one or more of these risks materialize (or the consequences of such development worsen), or should the underlying assumptions prove incorrect, actual results could differ materially from those currently forecasted or expected. We disclaim any intention or obligation to update or revise any forward-looking statement whether as a result of changes in information, future events or otherwise.

Segments

We have three consolidated operating segments at December 31, 2008:

Chemicals

Kronos Worldwide, Inc.

Our chemicals segment is operated through our majority ownership of Kronos. Kronos is a leading global producer and marketer of value-added titanium dioxide pigments ("TiO₂"). TiO₂, which imparts whiteness, brightness and opacity, is used for a variety of manufacturing applications including: plastics, paints, paper and other industrial products. Kronos has production facilities in Europe and North America. TiO₂ sales were over 90% of Kronos' sales in 2008.

Component Products

CompX International Inc.

We operate in the component products industry through our majority ownership of CompX. CompX is a leading manufacturer of security products, precision ball bearing slides and ergonomic computer support systems used in the office furniture, transportation, postal, tool storage, appliance and a variety of other industries. CompX is also a leading manufacturer of stainless steel exhaust systems, gauges and throttle controls for the performance marine industry. CompX has production facilities in North America and Asia.

Waste Management

Waste Control Specialists LLC

WCS is our wholly-owned subsidiary which owns and operates a West Texas facility for the processing, treatment, storage and disposal of hazardous, toxic and certain types of low-level radioactive waste. WCS obtained a byproduct disposal license in 2008 and is in the process of constructing the byproduct disposal facility, which is expected to be operational in the second half of 2009. In January 2009, WCS received a low-level radioactive waste disposal permit, and construction of the low-level radioactive waste facility is currently expected to begin in the second quarter of 2009, following the completion of some pre-construction licensing and administrative matters, and is expected to be operational in the second quarter of 2010.

For additional information about our segments and equity investments see "Part II - Item 7. Management's Discussion and Analysis of Financial Condition and Results of Operations" and Notes 2 and 7 to our Consolidated Financial Statements.

CHEMICALS SEGMENT - KRONOS WORLDWIDE, INC.

Business Overview - Through our majority-owned subsidiary, Kronos, we are a leading global producer and marketer of value-added TiO_2 , which is a white inorganic pigment used to impart whiteness, brightness and opacity for products such as coatings, plastics, paper, fibers, food, ceramics and cosmetics. Kronos and its predecessors have produced and marketed TiO_2 in North America and Europe for over 80 years. TiO_2 is considered a "quality-of-life" product with demand and growth affected by gross domestic product and overall economic conditions in various regions of the world. We produce TiO_2 in four facilities in Europe and two facilities in North America, including one facility in the U.S. that is owned by a 50/50 joint venture. We also mine ilmenite, the raw material used in the production of TiO_2 , in Norway.

TiO_2 's value is in its whitening properties and hiding power (opacity), which is the ability to cover or mask other materials effectively and efficiently. TiO_2 is the largest commercially used whitening pigment by volume because it provides more hiding power than any other commercially produced white pigment due to its high refractive index rating. In addition, TiO_2 has excellent resistance to interaction with other chemicals, good thermal stability and resistance to ultraviolet degradation. We ship TiO_2 to our customers in either a powder or slurry form via rail, truck or ocean carrier.

Approximately one-half of our 2008 TiO_2 sales volumes was to Europe. We believe we are the second-largest producer of TiO_2 in Europe, with an estimated 19% of European TiO_2 sales volumes. We estimate we have 16% of North American TiO_2 sales volumes.

Per capita consumption of TiO_2 in the United States and Western Europe far exceeds consumption in other areas of the world. We expect these markets to continue to be the largest consumers of TiO_2 for the foreseeable future. It is probable significant markets for TiO_2 could emerge in other areas of the world. China continues to develop into a significant market and as its economy continues to mature it is probable that quality-of-life products, including TiO_2 , will experience greater demand in that country. In addition, growth in recent years in Eastern Europe and the Far East has been significant as the economies in these regions continue developing to the point that quality-of-life products, including TiO_2 , experience greater demand.

Manufacturing, Operations and Products - We produce TiO_2 using two different methods: the chloride process and the sulfate process. The chloride process, which begins with raw natural rutile ore or purchased slag as the base, utilizes newer technology, is less labor intensive, requires less energy and results in less waste. The chloride process produces rutile TiO_2 which is preferred for the majority of customer applications because it has a bluer undertone and higher durability than sulfate process rutile TiO_2 . Chloride process rutile TiO_2 is preferred for use in coatings and plastics, the two largest end-use markets. As a result approximately three-fourths of the TiO_2 we produce is chloride based rutile. For the overall TiO_2 industry, chloride based TiO_2 sales have increased relative to sulfate process pigments over the last several years. The sulfate process, which begins with ilmenite ore or purchased slag as a base, produces both rutile and anatase TiO_2 . Anatase TiO_2 is a much smaller percentage of annual global TiO_2 production and is preferred for use in selected paper, ceramics, rubber tires, man-made fibers, food and cosmetics applications.

After the intermediate TiO_2 pigment is produced by either the chloride or sulfate process, it is "finished" into products with specific performance characteristics for particular end-use applications through proprietary processes involving various chemical surface treatments and intensive micronizing (milling). We currently produce over 40 different TiO_2 grades,

sold under our Kronos™ trademark, which provide a variety of performance properties to meet our customers' specific requirements. Our major customers include domestic and international paint, plastics and paper manufacturers. Directly and through our distributors and agents, we sell and provide technical services for our products to over 4,000 customers in over 100 countries, with the majority of our sales in Europe and North America.

We believe there are no effective substitutes for TiO₂. Extenders, such as kaolin clays, calcium carbonate and polymeric opacifiers, are used in a number of end-use markets as white pigments, however the opacity in these products is not able to duplicate the performance characteristics of TiO₂. Therefore, we believe these products are not an effective substitute for TiO₂.

Over the last 10 years we have focused on expanding our annual production capacity by obtaining additional operating efficiencies at our existing plants through modest capital expenditures. In 2008, we produced 514,000 metric tons of TiO₂ up from 512,000 metric tons in 2007. Our production records include our 50% share of TiO₂ produced at our joint-venture owned Louisiana facility. We believe our attainable production capacity for 2009 is approximately 532,000 metric tons; however, we do expect our production volumes in 2009 will be significantly lower than our attainable capacity. See Part II Item 7. *"Management's Discussion and Analysis of Financial Condition and Results of Operations - Chemicals Segment - Outlook"*.

TiO₂ sales were about 90% of our total Chemicals sales in 2008. The remaining 10% of our total chemical sales is comprised of other products that are complementary to our TiO₂ business. These products are as follows:

- We own and operate an ilmenite mine in Norway pursuant to a governmental concession with an unlimited term, and we are currently excavating a second mine located near the first mine. Ilmenite is a raw material used directly as a feedstock by some sulfate-process TiO₂ plants, including all of our European sulfate-process plants. We also sell ilmenite ore to third-parties, some of whom are our competitors. The mines have estimated aggregate reserves that are expected to last for at least another 60 years.
- We manufacture and sell iron-based chemicals, which are co-products and processed co-products of sulfate and chloride process TiO₂ pigment production. These co-product chemicals are marketed through our Ecochem division, and are used primarily as treatment and conditioning agents for industrial effluents and municipal wastewater as well as in the manufacture of iron pigments, cement and agricultural products.
- We manufacture and sell titanium oxychloride and titanyl sulfate, which are side-stream products from the production of TiO₂. Titanium oxychloride is used in specialty applications in the formulation of pearlescent pigments, production of electroceramic capacitors for cell phones and other electronic devices. Titanyl sulfate products are used primarily in pearlescent pigments.

Our Chemicals Segment operated the following TiO₂ facilities, two slurry facilities and an ilmenite mine at December 31, 2008.

<u>Location</u>	<u>Description</u>
Leverkusen, Germany (1)	TiO ₂ production, Chloride and sulfate process, co-products
Nordenham, Germany	TiO ₂ production, Sulfate process, co-products
Langerbrugge, Belgium	TiO ₂ production, Chloride process, co-products, titanium chemicals products
Fredrikstad, Norway (2)	TiO ₂ production, Sulfate process, co-products
Varenes, Quebec	TiO ₂ production, Chloride and sulfate process, slurry facility, titanium chemicals products
Lake Charles, Louisiana (3)	TiO ₂ production, Chloride process
Lake Charles, Louisiana	Slurry facility
Hauge I Dalane, Norway (4)	Ilmenite mine

- (1) The Leverkusen facility is located within an extensive manufacturing complex owned by Bayer AG. We own the Leverkusen facility, which represents about one-third of our current TiO₂ production capacity, but we lease the land under the facility from Bayer AG under a long term agreement which expires in 2050. Lease payments are periodically negotiated with Bayer for periods of at least two years at a time. Bayer provides some raw materials, including chlorine, auxiliary and operating materials, utilities and services necessary to operate the Leverkusen facility under separate supplies and services agreements.
- (2) The Fredrikstad plant is located on public land and is leased until 2013, with an option to extend the lease for an additional 50 years.
- (3) We operate this facility in a 50/50 joint venture with Huntsman Holdings LLC. See Note 7 to the Consolidated Financial Statements.
- (4) We are currently excavating a second mine located near our current mine in Norway.

Our Chemicals Segment also leases various corporate and administrative offices in the U.S. and various sales offices in the U.S. and Europe.

Raw Materials - The primary raw materials used in chloride process TiO₂ are titanium-containing feedstock (natural rutile ore or purchased slag), chlorine and coke. Chlorine and coke are available from a number of suppliers. Titanium-containing feedstock suitable for use in the chloride process is available from a limited, but increasing, number of suppliers principally in Australia, South Africa, Canada, India and the United States. We purchase chloride process grade slag from Rio Tinto Iron and Titanium, under a long-term supply contract that expires at the end of 2011. We purchase natural rutile ore primarily from Iluka Resources, Limited under a long-term supply contract that expires at the end of 2009. We expect to be successful in obtaining long-term extensions to these and other existing supply contracts prior to their expiration. We expect the raw materials purchased under these contracts to meet our chloride process feedstock requirements over the next several years.

The primary raw materials used in sulfate process TiO₂ are titanium-containing feedstock (primarily ilmenite from our Norwegian mine or purchased slag) and sulfuric acid. Sulfuric acid is available from a number of suppliers. Titanium-containing feed stock suitable for use in the sulfate process is available from a limited number of suppliers, principally in Norway, Canada, Australia, India and South Africa. As one of the few vertically-integrated producers of sulfate process TiO₂, we own and operate a rock ilmenite mine in Norway, which provided all the feedstock for our European sulfate process TiO₂ plants in 2008. We expect ilmenite production from our mine to meet our European sulfate process feedstock requirements for the foreseeable future. For our Canadian sulfate process plant, we also purchase sulfate grade slag, primarily from Q.I.T. Fer et Titane Inc. (also a

subsidiary of Rio Tinto Iron and Titanium), under a long-term supply contract that expires at the end of 2009 and Tinfos Titan and Iron KS under a supply contract that expires in 2010. We expect the raw materials purchased under these contracts to meet our sulfate process feedstock requirements over the next few years.

Many of our raw material contracts contain fixed quantities we are required to purchase, although these contracts allow for an upward or downward adjustment in the quantity purchased. Raw material pricing under these agreements is generally negotiated annually.

The following table summarizes our raw materials procured or mined in 2008.

<u>Production Process/Raw Material</u>	<u>Raw Materials Procured or Mined</u>
	(In thousands of metric tons)
Chloride process plants -	
purchased slag or natural rutile ore	422
Sulfate process plants:	
Raw ilmenite ore mined and used internally	305
Purchased slag	30

TiO₂ Manufacturing Joint Venture - We hold a 50% interest in a manufacturing joint venture with a subsidiary of Huntsman Corporation (Huntsman) (NYSE: HUN). The joint venture owns and operates a chloride process TiO₂ facility in Lake Charles, Louisiana. We share production from the facility equally with Huntsman pursuant to separate offtake agreements.

A supervisory committee composed of four members, two of whom we appoint and two of whom are appointed by Huntsman, directs the business and affairs of the joint venture, including production and output decisions. Two general managers, one we appoint and one appointed by Huntsman, manage the joint venture operations acting under the direction of the supervisory committee.

We are required to purchase one-half of the TiO₂ produced by the joint venture. Because we do not control the joint venture, it is not consolidated in our Consolidated Financial Statements; instead we use the equity method to account for our interest. The joint venture operates on a break-even basis, and therefore we do not have any equity in earnings of the joint venture. With the exception of raw material costs and packaging costs for the pigment grades produced, we share all costs and capital expenditures of the joint venture equally with Huntsman. Our share of the net costs is reported as cost of sales as the related TiO₂ is sold. See Note 7 to our Consolidated Financial Statements for additional financial information.

Patents and Trademarks - We hold patents for products and production processes which we believe are important to our continuing business activities. We seek patent protection for our technical developments, principally in the United States, Canada and Europe, and from time to time we enter into licensing arrangements with third parties. Our existing patents generally have terms of 20 years from the date of filing, and have remaining terms ranging from 1 to 19 years. We actively seek to protect our intellectual property rights, including our patent rights, and from time to time we are engaged in disputes relating to the protection and use of intellectual property relating to our products.

Our major trademarks, including Kronos™, are protected by registration in the United States and elsewhere with respect to those products we manufacture and sell. We also rely on unpatented proprietary knowledge and, continuing technological innovation and other trade secrets to develop and maintain our competitive position. Our proprietary chloride production process is an important part of our technology, and our business could be harmed if we fail to maintain confidentiality of trade secrets used in this technology.

Sales and Seasonality - We sell to a diverse customer base, with no single customer makes up more than 10% of our Chemicals Segment's sales in 2008. Our ten largest Chemicals Segment customers accounted for approximately 27% of the Chemicals Segment's 2008 sales. Due in part to the increase in paint production in the spring to meet spring and summer painting season demand, our sales are slightly seasonal with TiO₂ sales generally higher in the first half of the year.

Competition - The TiO₂ industry is highly competitive, with six major producers including us. Our five largest competitors are: E.I. du Pont de Nemours & Co. ("DuPont"), Millennium Inorganic Chemicals Inc. (a subsidiary of National Titanium Dioxide Company Ltd. (Cristal)), Tronox Incorporated, Huntsman and Ishihara Sangyo Kaisha, Ltd. These competitors have estimated individual shares of TiO₂ production capacity ranging from 4% (for Ishihara) to 22% (for DuPont), and an estimated aggregate share of worldwide TiO₂ production volume in excess of 60%. DuPont has about one-half of total North American TiO₂ production capacity and is our principal North American competitor. Tronox filed for Chapter 11 bankruptcy protection in January 2009, and it is unclear how and to what extent Tronox or a successor will compete in the TiO₂ industry at the conclusion of Tronox's bankruptcy proceedings.

We compete primarily on the basis of price, product quality and technical service, and the availability of high-performance pigment grades. Although certain TiO₂ grades are considered specialty pigments, the majority of our TiO₂ grades and substantially all of our production are considered commodity pigments with price generally being the most significant competitive factor. We believe we are the leading seller of TiO₂ in several countries, including Germany, with an estimated 11% of worldwide TiO₂ sales volumes in 2008. Overall, we are the world's fifth-largest producer of TiO₂.

Over the past ten years, we and our competitors have increased industry capacity through debottlenecking projects. Given the current economic environment and reduced industry demand, we do not expect any significant efforts will be undertaken by us or our competitors to further increase capacity through such projects for the foreseeable future. In addition, Huntsman announced the closure of one of its European facilities. We believe further shutdowns or closures in the industry are possible. Even with these reductions in industry capacity, capacity utilization rates by us and our competitors are expected to be lower in 2009 as compared to 2008 as a response to a reduction in industry-wide demand, which in turn will result in downward pressure on average TiO₂ selling prices. Once the economic environment improves and industry-wide demand increases, the expected reduction in industry-wide capacity through plant shutdowns should have a favorable impact on production capacity utilization, selling prices and profitability. However, the volatility of the near term economic environment makes it difficult to forecast future demand. If actual developments differ from our expectations, ours and the TiO₂ industry's performances could continue to be unfavorably affected longer than expected.

Worldwide capacity additions in the TiO₂ market resulting from construction of new plants require significant capital expenditures and substantial lead time (typically three to five years in our experience). We are not aware of any TiO₂ plants currently under construction, and we believe it is not likely that any new plants will be constructed in the foreseeable future.

Research and Development - Our research and development activities are directed primarily on improving the chloride and sulfate production processes, improving product quality and strengthening our competitive position by developing new pigment applications. Our research and development activities are conducted at our Leverkusen, Germany facility. We spent approximately \$11 million in 2006 and \$12 million in each of 2007 and 2008 on these activities and certain technical support programs. We plan to scale back our research and development activities in 2009 due to the current adverse economic environment; consequently our research and development expenditures in 2009 are expected to be lower as compared to our recent history.

We are continually improving the quality of our grades and we have been successful at developing new grades for existing and new applications to meet the needs of our customers and increase product life cycle. Since 2002, we have added 15 new grades for plastics, coatings, fiber or paper laminate applications.

Regulatory and Environmental Matters - Our operations are governed by various environmental laws and regulations. Certain of our operations are, or have been, engaged in the handling, manufacture or use of substances or compounds that may be considered toxic or hazardous within the meaning of applicable environmental laws and regulations. As with other companies engaged in similar businesses, certain of our past and current operations and products have the potential to cause environmental or other damage. We have implemented and continue to implement various policies and programs in an effort to minimize these risks. Our policy is to maintain compliance with applicable environmental laws and regulations at all of our facilities and to strive to improve our environmental performance. It is possible that future developments, such as stricter requirements in environmental laws and enforcement policies, could adversely affect our production, handling, use, storage, transportation, sale or disposal of such substances and could adversely affect our consolidated financial position, results of operations or liquidity.

Our U.S. manufacturing operations are governed by federal environmental and worker health and safety laws and regulations, principally the Resource Conservation and Recovery Act ("RCRA"), the Occupational Safety and Health Act, the Clean Air Act, the Clean Water Act, the Safe Drinking Water Act, the Toxic Substances Control Act ("TSCA"), and the Comprehensive Environmental Response, Compensation and Liability Act, as amended by the Superfund Amendments and Reauthorization Act ("CERCLA"), as well as the state counterparts of these statutes. We believe our joint venture Louisiana TiO₂ facility and a Louisiana TiO₂ slurry facility we own are in substantial compliance with applicable requirements of these laws or compliance orders issued thereunder. These are our only U.S. facilities.

While the laws regulating operations of industrial facilities in Europe vary from country to country, a common regulatory framework is provided by the European Union ("EU"). Germany and Belgium are members of the EU and follow its initiatives. Norway, although not a member but generally patterns its environmental regulations after the EU. We believe we have obtained all required permits and we are in substantial compliance with applicable environmental requirements for our European and Canadian facilities.

At our sulfate plant facilities in Germany, we recycle weak sulfuric acid either through contracts with third parties or at our own facilities. In addition, at our German sulfate process facilities we have contracted with a third-party to treat certain sulfate-process effluents. At our Norwegian plant, we ship spent acid to a third-party location where it is used as a neutralization agent. These contracts may be terminated by either party after giving three or four years advance notice, depending on the contract.

From time to time, our facilities may be subject to environmental regulatory enforcement under U.S. and foreign statutes. Typically we establish compliance programs to resolve such matters. Occasionally, we may pay penalties, but to date such penalties have not had a material adverse effect on our consolidated financial position, results of operations or liquidity. We believe all of our facilities are in substantial compliance with applicable environmental laws.

In December 2006, the EU approved Registration, Evaluation and Authorization of Chemicals ("REACH"), which took effect on June 1, 2007, and will be phased in over 11 years. Under REACH, companies that manufacture or import more than one ton of a chemical substance per year will be required to register such chemical substances in a central data base. REACH affects our European operations by imposing on us a testing, evaluation and registration program for many of the chemicals we use or produce. We have established a REACH team that is working to identify and list all substances purchased, manufactured or imported by or for us in the EU. We spent \$.4 million in 2007 and \$.5 million in 2008 on REACH compliance, and we do not anticipate that future compliance costs will be material to us.

Capital expenditures in 2008 related to ongoing environmental compliance, protection and improvement programs were \$11.9 million, and are currently expected to be approximately \$1 million in 2009.

Employees - As of December 31, 2008, our Chemicals Segment employed the following number of people:

Europe	2,000
Canada	400
United States ⁽¹⁾	50
Total	<u>2,450</u>

⁽¹⁾ Excludes employees of our Louisiana joint venture.

Our hourly employees in production facilities worldwide, including the TiO₂ joint venture, are represented by a variety of labor unions under labor agreements with various expiration dates. Our European Union employees are covered by master collective bargaining agreements in the chemicals industry that are generally renewed annually. Our Canadian union employees are covered by a collective bargaining agreement that expires in June 2010.

COMPONENT PRODUCTS SEGMENT - COMPX INTERNATIONAL INC.

Business Overview - Through our majority-owned subsidiary, CompX, we manufacture components that are sold to a variety of industries including office furniture, recreational transportation (including performance boats), mailboxes, tool boxes, appliances, banking equipment, vending equipment and computers and related equipment. Our products are principally designed for use in medium to high-end product applications, where design, quality and durability are valued by our customers.

Manufacturing, Operations and Products - We manufacture locking mechanisms and other security products for sale to the postal, transportation, office furniture, banking, vending, and other industries. We believe we are a

North American market leader in the manufacture and sale of cabinet locks and other locking mechanisms. Our security products are used in a variety of applications including ignition systems, mailboxes, vending and gaming machines, parking meters, electrical circuit panels, storage compartments, office furniture and medical cabinet security. These products include:

- disc tumbler locks, which provide moderate security and generally represent the lowest cost lock to produce;
- pin tumbler locking mechanisms, which are more costly to produce and are used in applications requiring higher levels of security, including our *KeySet* high security system, which allows the user to change the keying on a single lock 64 times without removing the lock from its enclosure; and
- our innovative *eLock*® electronic locks, which provide stand alone security and audit trail capability for drug storage and other valuables through the use of a proximity card, magnetic stripe, or keypad credentials.

A substantial portion of our security products' sales consist of products with specialized adaptations to individual manufacturer's specifications, some of which are listed above. We also have a standardized product line suitable for many customers which is offered through a North American distribution network to lock distributors and smaller original equipment manufacturers ("OEMs") via our *STOCK LOCKS* distribution program.

We manufacture a complete line of furniture components (precision ball bearing slides and ergonomic computer support systems) for use in applications such as computer related equipment, appliances, tool storage cabinets, imaging equipment, file cabinets, desk drawers, automated teller machines, and other applications. These products include:

- our patented *Integrated Slide Lock*, which allows a file cabinet manufacturer to reduce the possibility of multiple drawers being opened at the same time;
- our patented adjustable *Ball Lock*, which reduces the risk of heavily-filled drawers, such as auto mechanic tool boxes, from opening while in movement;
- our *Self-Closing Slide*, which is designed to assist in closing a drawer and is used in applications such as bottom mount freezers;
- articulating computer keyboard support arms (designed to attach to desks in the workplace and home office environments to alleviate possible strains and stress and maximize usable workspace), along with our patented *LeverLock* keyboard arm, which is designed to make ergonomic adjustments of the keyboard arm easier;
- CPU storage devices which minimize adverse effects of dust and moisture; and
- complimentary accessories, such as ergonomic wrist rest aids, mouse pad supports and flat screen computer monitor support arms.

We also manufacture and distribute marine instruments, hardware and accessories for performance boats. Our specialty marine component products are high performance components designed to operate within precise tolerances in the highly corrosive marine environment. These products include:

- original equipment and aftermarket stainless steel exhaust headers, exhaust pipes, mufflers and other exhaust components;
- high performance gauges such as GPS speedometers and tachometers;
- controls, throttles, steering wheels and other billet accessories; and
- dash panels, LED lighting, rigging and other accessories.

Our Component Products segment operated the following manufacturing facilities at December 31, 2008:

Security Products

Mauldin, SC
Grayslake, IL

Furniture Components

Kitchener, Ontario
Byron Center, MI
Taipei, Taiwan

Marine Components

Neenah, WI
Grayslake, IL

We also lease a distribution facility located in California.

Raw Materials - Our primary raw materials are:

- zinc, copper and brass (used in the Security Products business unit for the manufacture of locking mechanisms);
- coiled steel (used in the Furniture Components business unit for the manufacture of precision ball bearing slides and ergonomic computer support systems);
- stainless steel (used in the Marine Components business unit for the manufacture of exhaust headers and pipes and other components; and
- plastic resins (used primarily in the Furniture Components business unit for injection molded plastics employed in the manufacturing of ergonomic computer support systems).

These raw materials are purchased from several suppliers and are readily available from numerous sources.

We occasionally enter into raw material arrangements to mitigate the short-term impact of future increases in raw material costs. While these arrangements do not necessarily commit us to a minimum volume of purchases, they generally provide for stated unit prices based upon achievement of specified purchase volumes. We utilize purchase arrangements to stabilize our raw material prices provided we meet the specified minimum monthly purchase quantities. Raw materials purchased outside of these arrangements are sometimes subject to unanticipated and sudden price increases. Due to the competitive nature of the markets served by our products, it is often difficult to recover all increases in raw material costs through increased product selling prices or raw material surcharges. Consequently, overall operating margins can be affected by such raw material cost pressures. All of our primary raw materials are impacted by related commodity markets where prices are cyclical, reflecting overall economic trends and specific developments in consuming industries.

Patents and Trademarks - Our Component Products Segment holds a number of patents relating to its component products, certain of which we believe are important to our continuing business activity. Patents generally have a term of 20 years, and our patents have remaining terms ranging from less than one year to 15 years at December 31, 2008. Our major trademarks and brand names include:

Furniture Components

CompX Precision Slides®
CompX Waterloo®
CompX ErgonomX®
CompX DurISlide®
Dynaslide®
Waterloo Furniture
Components Limited®

Security Products

CompX Security Products®
National Cabinet Lock®
Fort Lock®
Timberline®
Chicago Lock®
STOCK LOCKS®
KeSet®
TuBar®
ACE II®
CompX eLock®
Lockview® Software

Marine Components

Custom Marine®
Livorsi Marine®
CMI Industrial Mufflers™
Custom Marine Stainless
Exhaust™
The #1 Choice in
Performance Boating®
Mega Rim™
Race Rim™
CompX Marine™

Sales, Marketing and Distribution - Our Component Products Segment sells directly to large OEM customers through our factory-based sales and marketing professionals and with engineers working in concert with field salespeople and independent manufacturers' representatives. We select manufacturers' representatives based on special skills in certain markets or relationships with current or potential customers.

A significant portion of our sales are also made through distributors. We have a significant market share of cabinet lock sales as a result of the locksmith distribution channel. We support our distributor sales with a line of standardized products used by the largest segments of the marketplace. These products are packaged and merchandised for easy availability and handling by distributors and end users. Due to our success with the *STOCK LOCKS* inventory program within the security products business unit, similar programs have been implemented for distributor sales of ergonomic computer support systems within the furniture components business unit.

In 2008, our ten largest customers accounted for approximately 35% of our total sales; however, no one customer accounted for sales of 10% or more in 2008. Of the 35%, 15% was related to the security products business unit and 20% was related to the furniture components. Overall, our customer base is diverse and the loss of any single customer would not have a material adverse effect on our operations.

Competition - The markets in which our Component Products Segment competes are highly competitive. We compete primarily on the basis of product design, including ergonomic and aesthetic factors, product quality and durability, price, on-time delivery, service and technical support. We focus our efforts on the middle and high-end segments of the market, where product design, quality, durability and service are valued by the customer.

Our performance marine components business unit's products compete with small domestic manufacturers and is minimally affected by foreign competitors. Our security products and furniture components business units' products compete against a number of domestic and foreign manufacturers. Suppliers, particularly the Asian based furniture components suppliers, have put intense price pressure on our products. In some cases, we have lost sales to these lower cost foreign manufacturers. We have responded by

- shifting the manufacture of some products to our lower cost facilities,
- working to reduce costs and gain operational efficiencies through workforce reductions and lean process improvements in all of our facilities, and
- by working with our customers to be their value-added supplier of choice by offering customer support services which Asian based suppliers are generally unable to provide.

Regulatory and Environmental Matters - Our facilities are subject to federal, state, local and foreign laws and regulations relating to the use, storage, handling, generation, transportation, treatment, emission, discharge, disposal, remediation of and exposure to hazardous and non-hazardous substances, materials and wastes. We are also subject to federal, state, local and foreign laws and regulations relating to worker health and safety. We believe we are in substantial compliance with all such laws and regulations. To date, the costs of maintaining compliance with such laws and regulations have not significantly impacted our Component Products Segment's results. We currently do not anticipate any significant costs or expenses relating to such matters; however, it is possible future laws and regulations may require us to incur significant additional expenditures.

Employees - As of December 31, 2008, we employed the following number of people:

United States	658
Canada ⁽¹⁾	237
Taiwan	81
Total	<u>976</u>

⁽¹⁾ Approximately 75% of our Canadian employees are represented by a labor union covered by a new collective bargaining agreement. A new collective bargaining agreement, providing for wage increases from 0% to 1%, was ratified in January 2009 and expires in January 2012.

We believe our labor relations are good at all of our facilities.

WASTE MANAGEMENT SEGMENT - WASTE CONTROL SPECIALISTS LLC

Business Overview - Our Waste Management Segment was formed in 1995 and in early 1997 we completed construction of the initial phase of our waste disposal facility in West Texas. The facility is designed for the processing, treatment, storage and disposal of certain hazardous and toxic wastes. We received the first wastes for disposal in 1997. Subsequently, we have expanded our permitting authorizations to include the processing, treatment and storage of low-level radioactive waste ("LLRW") and mixed LLRW and the disposal of certain types of exempt low-level radioactive wastes. In January 2009 we obtained the final license we need to begin full scale operations of our waste disposal facility.

We currently operate our waste disposal facility on a relatively limited basis. We have begun construction on the byproduct material disposal site, which is expected to be operational in the second half of 2009. We currently expect to begin construction of the LLRW site in the second quarter of 2009 and, following the completion of some pre-construction licensing and administrative matters, it is expected to be operational in the second quarter of 2010.

Facility, Operations and Services - Our Waste Management Segment has permits by the Texas Commission on Environmental Quality ("TCEQ") and the U.S. Environmental Protection Agency ("EPA") to accept hazardous and toxic wastes governed by RCRA and TSCA. In October 2005, our RCRA permit was renewed for a new ten-year period. Likewise in September 2005, our five-year TSCA authorization was renewed for a new five-year period. Our RCRA permit and TSCA authorization are subject to additional renewals by the agencies assuming we remain in compliance with the provisions of the permits.

In November 1997, the Texas Department of State Health Services ("TDSHS") issued a license to us for the treatment and storage, but not disposal, of low-level and mixed low-level radioactive wastes. In June 2007, the TDSHS regulatory authority for this license was transferred to TCEQ. The current provisions of this license generally enable us to accept such wastes for treatment and storage from U.S. commercial and federal generators, including the Department of Energy ("DOE") and other governmental agencies. We accepted the first shipments of such wastes in 1998. We have obtained additional authority to dispose of certain categories of LLRW including naturally-occurring radioactive material ("NORM") and exempt-level materials (radioactive materials that do not exceed certain specified radioactive concentrations and are exempt from licensing). In May 2008, TCEQ issued us a license for the disposal of byproduct material and in January 2009 issued us a near-surface low-level and mixed disposal license.

Our waste disposal facility also serves as a staging and processing location for material that requires other forms of treatment prior to final disposal as mandated by the EPA or other regulatory bodies. Our 20,000 square foot treatment facility provides for waste treatment/stabilization, warehouse storage, treatment facilities for hazardous, toxic and mixed LLRW, drum to bulk, and bulk to drum materials handling and repackaging capabilities. Treatment operations involve processing wastes through one or more chemical or other treatment methods, depending upon the particular waste being disposed and regulatory and customer requirements. Chemical treatment uses chemical oxidation and reduction, chemical precipitation of heavy metals, hydrolysis and neutralization of acid and alkaline wastes, and results in the transformation of waste into inert materials through one or more of these chemical processes. Certain treatment processes involve technology which we may acquire, license or subcontract from third parties.

Once treated and stabilized, waste is either; (i) placed in our landfill, (ii) stored onsite in drums or other specialized containers or (iii) shipped to third-party facilities for final disposition. Only waste that meets certain specified regulatory requirements can be disposed of in our fully-lined landfill, which includes a leachate collection system.

We operate one waste management facility located on a 1,338-acre site in West Texas, which we own. The site is permitted for 5.4 million cubic yards of airspace landfill capacity for the disposal of RCRA and TSCA wastes. We also own approximately 13,500 acres of additional land surrounding the permitted site, a small portion of which is located in New Mexico, which is available for future expansion. We believe our facility has superior geological characteristics which make it an environmentally-desirable location for this type of waste disposal. The facility is located in a relatively remote and arid section of West Texas. The possibility of leakage into any underground water table is considered highly remote because the ground is composed of triassic red bed clay and we do not believe there are any underground aquifers or other usable sources of water below the site based in part on extensive drilling by the oil and gas industry and our own test wells.

Sales - Our Waste Management Segment's target customers are industrial companies, including chemical, aerospace and electronics businesses and governmental agencies, including DOE, which generate hazardous, mixed low-level radioactive and other wastes. We employ our own salespeople to market our services to potential customers.

Competition - The hazardous waste industry (other than low-level and mixed LLRW) currently has excess industry capacity caused by a number of factors, including a relative decline in the number of environmental remediation projects generating hazardous wastes and efforts on the part of waste generators to reduce the volume of waste and/or manage waste onsite at their facilities. These factors have led to reduced demand and increased price pressure for non-radioactive hazardous waste management services. While we believe our broad range of permits for the treatment and storage of low-level and LLRW streams provides us certain competitive advantages, a key element of our long-term strategy is to provide "one-stop shopping" for hazardous, low-level and mixed LLRW. To offer this service we will have to complete construction of the facilities we have been licensed to operate.

Competition within the hazardous waste industry is diverse and based primarily on facility location/proximity to customers, pricing and customer service. We expect price competition to continue to be intense for RCRA- and TSCA-related wastes. With respect to our currently-permitted activities, our principal competitors are Energy Solutions, LLC, American Ecology Corporation and Perma-Fix Environmental Services, Inc. These competitors are well established and have significantly greater resources than we do, which could be important factors to our potential customers. We believe we may have

certain competitive advantages, including our environmentally-desirable location, broad level of local community support, a rail transportation network leading to our facility and our capability for future site expansion.

The low-level radioactive waste industry has very limited competition because; (i) commercial low-level waste disposal facilities can only be licensed by the Nuclear Regulatory Commission ("NRC") or states that have an agreement with NRC to assume portions of its regulatory authority ("Agreement States"), (ii) the facilities must be designed, constructed and operated to meet strict safety standards and (iii) the operator of the facility must extensively characterize the site on which the facility is located and analyze how the facility will perform for thousands of years into the future. Prior to the receipt of our license, there were only three low-level waste disposal facilities in the United States. None of the three disposal facilities accept Class B or C LLRW from generators located in states which do not have a formal agreement with the state in which the disposal facility is located (the "Compact System" or the "Compact"). We believe we will be very competitive due to the limited amount of competition and our "one-stop shopping" capabilities once our new facilities are constructed and in operation.

Regulatory and Environmental Matters - While the waste management industry has benefited from increased governmental regulation, it has also become subject to extensive and evolving regulation by federal, state and local authorities. The regulatory process requires waste management businesses to obtain and retain numerous operating permits covering various aspects of their operations, any of which could be subject to revocation, modification or denial. Regulations also allow public participation in the permitting process. Individuals as well as companies may oppose the granting of permits. In addition, governmental policies and the exercise of broad discretion by regulators are subject to change. It is possible our ability to obtain and retain permits on a timely basis could be impaired in the future. The loss of an individual permit or the failure to obtain a permit could have a significant impact on our Waste Management Segment's future operating plans, financial condition, results of operations or liquidity, especially because we only own and operate one disposal site. For example, adverse decisions by governmental authorities on our permit applications could cause us to abandon projects, prematurely close our facility or restrict operations. Our RCRA permit and our license from TCEQ, as amended, expires in 2015 and our TSCA authorization expires in 2010. Such permits, licenses and authorizations can be renewed subject to compliance with the requirements of the application process and approval by TCEQ or EPA, as applicable.

In May 2008, TCEQ issued us a license for the disposal of byproduct material. Byproduct material includes uranium or thorium mill tailings as well as equipment, pipe and other materials used to handle and process the mill tailings. We began construction of the byproduct facility infrastructure at our site in Andrews County, Texas in the third quarter of 2008. In January 2009, TCEQ issued us a near-surface low-level and mixed LLRW disposal license.

From time to time federal, state and local authorities have proposed or adopted other types of laws and regulations for the waste management industry, including laws and regulations restricting or banning the interstate or intrastate shipment of certain waste, changing the regulatory agency issuing a license, imposing higher taxes on out-of-state waste shipments compared to in-state shipments, reclassifying certain categories of hazardous waste as non-hazardous and regulating disposal facilities as public utilities. Certain states have issued regulations that attempt to prevent waste generated within a particular Compact from being sent to disposal sites outside that Compact. The U.S. Congress has also considered legislation that would enable or facilitate such bans, restrictions, taxes and regulations. Due to the complex nature of industry regulation, implementation of existing or future laws and regulations

by different levels of government could be inconsistent and difficult to foresee. While we attempt to monitor and anticipate regulatory, political and legal developments that affect the industry, we cannot assure you we will be able to do so. Nor can we predict the extent to which legislation or regulations that may be enacted, or any failure of legislation or regulations to be enacted, may affect our operations in the future.

The demand for certain hazardous waste services we intend to provide is dependent in large part upon the existence and enforcement of federal, state and local environmental laws and regulations governing the discharge of hazardous waste into the environment. We and the industry as a whole could be adversely affected to the extent such laws or regulations are amended or repealed or their enforcement is lessened.

Because of the high degree of public awareness of environmental issues, companies in the waste management business may be, in the normal course of their business, subject to judicial and administrative proceedings. Governmental agencies may seek to impose fines or revoke, deny renewal of, or modify any applicable operating permits or licenses. In addition, private parties and special interest groups could bring actions against us alleging, among other things, a violation of operating permits or opposition to new license authorizations.

Employees - At December 31, 2008, we had 121 employees. We believe our labor relations are good.

OTHER

NL Industries, Inc. - At December 31, 2008, NL owned 87% of CompX and 36% of Kronos. NL also owns 100% of EWI RE, Inc., an insurance brokerage and risk management services company and also holds certain marketable securities and other investments. See Note 16 to our Consolidated Financial Statements for additional information.

Tremont LLC - Tremont is primarily a holding company through which we hold indirect ownership interests in Basic Management, Inc. ("BMI"), which provides utility services to, and owns property (the "BMI Complex") adjacent to, TIMET's facility in Nevada, and The Landwell Company L.P. ("Landwell"), which is engaged in efforts to develop certain land holdings for commercial, industrial and residential purposes surrounding the BMI Complex.

Business Strategy - We routinely compare our liquidity requirements and alternative uses of capital against the estimated future cash flows to be received from our subsidiaries and unconsolidated affiliates, and the estimated sales value of those businesses. As a result, we have in the past, and may in the future, seek to raise additional capital, refinance or restructure indebtedness, repurchase indebtedness in the market or otherwise, modify our dividend policy, consider the sale of an interest in our subsidiaries, business units, marketable securities or other assets, or take a combination of these or other steps, to increase liquidity, reduce indebtedness and fund future activities, which have in the past and may in the future involve related companies. From time to time, we and our related entities consider restructuring ownership interests among our subsidiaries and related companies. We expect to continue this activity in the future.

We and other entities that may be deemed to be controlled by or affiliated with Mr. Harold C. Simmons routinely evaluate acquisitions of interests in, or combinations with, companies, including related companies, we perceive to be undervalued in the marketplace. These companies may or may not be engaged in businesses related to our current businesses. In some instances we actively manage the businesses we acquire with a focus on maximizing return-on-investment through cost reductions, capital expenditures, improved operating efficiencies, selective marketing to address market niches, disposition of marginal operations, use of leverage and redeployment of capital to more

productive assets. In other instances, we have disposed of our interest in a company prior to gaining control. We intend to consider such activities in the future and may, in connection with such activities, consider issuing additional equity securities and increasing our indebtedness.

Website and Available Information - Our fiscal year ends December 31. We furnish our stockholders with annual reports containing audited financial statements. In addition, we file annual, quarterly and current reports, proxy and information statements and other information with the SEC. Certain of our consolidated subsidiaries (Kronos, NL and CompX) also file annual, quarterly and current reports, proxy and information statements and other information with the SEC. We also make our annual report on Form 10-K, quarterly reports on Form 10-Q, current reports on Form 8-K and amendments thereto, available free of charge through our website at www.valhi.net as soon as reasonably practical after they have been filed with the SEC. We also provide to anyone, without charge, copies of such documents upon written request. Requests should be directed to the attention of the Corporate Secretary at our address on the cover page of this Form 10-K.

Additional information, including our Audit Committee charter, our Code of Business Conduct and Ethics and our Corporate Governance Guidelines, can also be found on our website. Information contained on our website is not part of this Annual Report.

The general public may read and copy any materials we file with the SEC at the SEC's Public Reference Room at 100 F Street, NE, Washington, DC 20549. The public may obtain information on the operation of the Public Reference Room by calling the SEC at 1-800-SEC-0330. We are an electronic filer. The SEC maintains an Internet website at www.sec.gov that contains reports, proxy and information statements and other information regarding issuers that file electronically with the SEC, including us.

ITEM 1A. RISK FACTORS

Listed below are certain risk factors associated with us and our businesses. In addition to the potential effect of these risk factors discussed below, any risk factor which could result in reduced earnings or operating losses, or reduced liquidity, could in turn adversely affect our ability to service our liabilities or pay dividends on our common stock or adversely affect the quoted market prices for our securities.

Our assets consist primarily of investments in our operating subsidiaries, and we are dependent upon distributions from our subsidiaries to service our liabilities.

A significant portion of our assets consists of ownership interests in our subsidiaries and affiliates. A majority of our cash flows are generated by our subsidiaries, and our ability to service our liabilities and to pay dividends on our common stock depends to a large extent upon the cash dividends or other distributions we receive from our subsidiaries. Our subsidiaries and affiliates are separate and distinct legal entities and they have no obligation, contingent or otherwise, to pay cash dividends or other distributions to us. In addition, in some cases our subsidiaries' ability to pay dividends or other distributions could be subject to restrictions as a result of debt covenants, applicable tax laws or other restrictions imposed by current or future agreements. Events beyond our control, including changes in general business and economic conditions, could adversely impact the ability of our subsidiaries to pay dividends or make other distributions to us. If our subsidiaries should become unable to make sufficient cash dividends or other distributions to us, our ability to service our liabilities and to pay dividends on our common stock could be adversely affected.

In this regard, in the first quarter of 2009 Kronos announced the suspension of its regularly quarterly dividend in consideration of the

challenges and opportunities that exist in the TiO₂ pigment industry. We currently believe we will have sufficient liquidity to service our liabilities in 2009. In February 2009, our Board of Directors declared a first quarter 2009 cash dividend of \$.10 per share to shareholders of record as of March 10, 2009 to be paid on March 31, 2009. However, the declaration and payment of future dividends, and the amount thereof, is discretionary and is dependent upon our results of operations, financial condition, cash requirements for businesses, contractual restrictions and other factors deemed relevant by our Board of Directors. The amount and timing of past dividends is not necessarily indicative of the amount or timing of any future dividends which might be paid. Our revolving bank credit facility currently limits the amount of our quarterly cash dividends to \$.10 per share, plus an additional aggregate amount of \$193.0 million at December 31, 2008.

In addition, if the level of dividends and other distributions we receive from our subsidiaries were to decrease to such a level that we were required to liquidate any of our investments in the securities of our subsidiaries or affiliates in order to generate funds to satisfy our liabilities, we may be required to sell such securities at a time or times at which we would not be able to realize what we believe to be the actual value of such assets.

Demand for, and prices of, certain of our products are influenced by changing market conditions and we are currently operating in a depressed worldwide market for our products, which may result in reduced earnings or operating losses.

Approximately 90% of our revenues are attributable to sales of TiO₂. Pricing within the global TiO₂ industry over the long term is cyclical, and changes in economic conditions, especially in Western industrialized nations, can significantly impact our earnings and operating cash flows. The current worldwide economic downturn has depressed sales volumes in the fourth quarter of 2008 and we are unable to predict with a high degree of certainty when demand will return to the levels experienced prior to the fourth quarter of 2008. This may result in reduced earnings or operating losses.

Historically, the markets for many of our products have experienced alternating periods of increasing and decreasing demand. Relative changes in the selling prices for our products are one of the main factors that affect the level of our profitability. In periods of increasing demand, our selling prices and profit margins generally will tend to increase, while in periods of decreasing demand our selling prices and profit margins generally tend to decrease. Huntsman announced the closure of one of its European facilities, and we believe further shutdowns or closures in the industry are possible. The closures may not be sufficient to alleviate the current excess industry capacity, and such conditions may be further aggravated by anticipated or unanticipated capacity additions or other events.

The demand for TiO₂ during a given year is also subject to annual seasonal fluctuations. TiO₂ sales are generally higher in the first half of the year. This is due in part to the increase in paint production in the spring to meet demand during the spring and summer painting season. See Item 7. "Management's Discussion and Analysis of Financial Condition and Results of Operations" for further discussion on production and price changes.

We sell several of our products in mature and highly-competitive industries and face price pressures in the markets in which we operate, which may result in reduced earnings or operating losses.

The global markets in which Kronos, CompX and WCS operate their businesses are highly competitive. Competition is based on a number of factors, such as price, product quality and service. Some of our competitors

may be able to drive down prices for our products because their costs are lower than our costs. In addition, some of our competitors' financial, technological and other resources may be greater than our resources, and these competitors may be better able to withstand negative market conditions. Our competitors may be able to respond more quickly than we can to new or emerging technologies and changes in customer requirements. Further, consolidation of our competitors or customers in any of the industries in which we compete may result in reduced demand for our products or make it more difficult for us to compete with our competitors. In addition, in some of our businesses new competitors could emerge by modifying their existing production facilities so they could manufacture products that compete with our products. The occurrence of any of these events could result in reduced earnings or operating losses.

Higher costs or limited availability of our raw materials may reduce our earnings and decrease our liquidity.

The number of sources and availability of certain raw materials is specific to the particular geographical regions in which our facilities are located. For example, titanium-containing feedstocks suitable for use in producing our TiO₂ are available from a limited number of suppliers around the world. Political and economic instability in the countries from which we purchase our raw material supplies could adversely affect their availability. If our worldwide vendors were not able to meet their contractual obligations and we were otherwise unable to obtain necessary raw materials or if we would have to pay more for our raw materials and other operating costs, we may be required to reduce production levels or reduce our gross margins if we were unable to pass price increases onto our customers, which may decrease our liquidity, operating income and results of operations.

We could incur significant costs related to legal and environmental remediation matters.

NL formerly manufactured lead pigments for use in paint. NL and others pigment manufacturers have been named as defendants in various legal proceedings seeking damages for personal injury, property damage and governmental expenditures allegedly caused by the use of lead-based paints. These lawsuits seek recovery under a variety of theories, including public and private nuisance, negligent product design, negligent failure to warn, strict liability, breach of warranty, conspiracy/concert of action, aiding and abetting, enterprise liability, market share or risk contribution liability, intentional tort, fraud and misrepresentation, violations of state consumer protection statutes, supplier negligence and similar claims. The plaintiffs in these actions generally seek to impose on the defendants responsibility for lead paint abatement and health concerns associated with the use of lead-based paints, including damages for personal injury, contribution and/or indemnification for medical expenses, medical monitoring expenses and costs for educational programs. As with all legal proceedings, the outcome is uncertain. Any liability NL might incur in the future could be material. See also Item 3. *Legal Proceedings*.

Certain properties and facilities used in our former businesses are the subject of litigation, administrative proceedings or investigations arising under various environmental laws. These proceedings seek cleanup costs, personal injury or property damages and/or damages for injury to natural resources. Some of these proceedings involve claims for substantial amounts. Environmental obligations are difficult to assess and estimate for numerous reasons, and we may incur costs for environmental remediation in the future in excess of amounts currently estimated. Any liability we might incur in the future could be material.

Our failure to enter into new markets with our current component products businesses would result in the continued significant impact of fluctuations in demand within the office furniture manufacturing industry on our operating results.

In an effort to reduce our dependence on the office furniture market for certain products and to increase our participation in other markets, we have been devoting resources to identifying new customers and developing new applications for those products in markets outside of the office furniture industry, such as home appliances, tool boxes and server racks. Developing these new applications for our products involves substantial risk and uncertainties due to our limited experience with customers and applications in these markets, as well as facing competitors who are already established in these markets. We may not be successful in developing new customers or applications for our products outside of the office furniture industry. Significant time may be required to develop new applications and uncertainty exists as to the extent to which we will face competition in this regard.

Our development of innovative features for current products is critical to sustaining and growing our Component Product Segment's sales.

Historically, our ability to provide value-added custom engineered products that address requirements of technology and space utilization has been a key element of our success. We spend a significant amount of time and effort to refine, improve and adapt our existing products for new customers and applications. Since expenditures for these types of activities are not considered research and development expense under accounting principles generally accepted in the United States of America, the amount of our research and development expenditures, which is not significant, is not indicative of the overall effort involved in the development of new product features. The introduction of new product features requires the coordination of the design, manufacturing and marketing of the new product features with current and potential customers. The ability to coordinate these activities with current and potential customers may be affected by factors beyond our control. While we will continue to emphasize the introduction of innovative new product features that target customer-specific opportunities, there can be no assurance that any new product features we introduce will achieve the same degree of success that we have achieved with our existing products. Introduction of new product features typically requires us to increase production volume on a timely basis while maintaining product quality. Manufacturers often encounter difficulties in increasing production volumes, including delays, quality control problems and shortages of qualified personnel or raw materials. As we attempt to introduce new product features in the future, there can be no assurance that we will be able to increase production volume without encountering these or other problems, which might negatively impact our financial condition or results of operations.

Negative worldwide economic conditions could continue to result in a decrease in our sales and an increase in our operating costs, which could continue to adversely affect our business and operating results.

If the current worldwide economic downturn continues, many of our direct and indirect customers may continue to delay or reduce their purchases of the products we manufacture or products that utilize our products. In addition, many of our customers rely on credit financing for their working capital needs. If the negative conditions in the global credit markets continue to prevent our customers' access to credit, product orders may continue to decrease which could result in lower sales. Likewise, if our suppliers continue to face challenges in obtaining credit, in selling their products or otherwise in operating their businesses, they may become unable to continue to offer the materials we use to manufacture our products. These actions could continue to result in reductions in our sales, increased price competition and increased operating costs, which could adversely affect our business, results of operations and financial condition.

Negative global economic conditions increase the risk that we could suffer unrecoverable losses on our customers' accounts receivable which would adversely affect our financial results.

We extend credit and payment terms to some of our customers. Although we have an ongoing process of evaluating our customers' financial condition, we could suffer significant losses if a customer fails and is unable to pay us. A significant loss of an accounts receivable would have a negative impact on our financial results.

Our leverage may impair our financial condition or limit our ability to operate our businesses.

We have a significant amount of debt, primarily related to Kronos' Senior Secured Notes and our loans from Snake River Sugar Company. Our level of debt could have important consequences to our stockholders and creditors, including:

- making it more difficult for us to satisfy our obligations with respect to our liabilities;
- increasing our vulnerability to adverse general economic and industry conditions;
- requiring that a portion of our cash flow from operations be used for the payment of interest on our debt, reducing our ability to use our cash flow to fund working capital, capital expenditures, dividends on our common stock, acquisitions and general corporate requirements;
- limiting our ability to obtain additional financing to fund future working capital, capital expenditures, acquisitions or general corporate requirements;
- limiting our flexibility in planning for, or reacting to, changes in our business and the industry in which we operate; and
- placing us at a competitive disadvantage relative to other less leveraged competitors.

In addition to our indebtedness, we are party to various lease and other agreements pursuant to which we are committed to pay approximately \$385 million in 2009. Our ability to make payments on and refinance our debt, and to fund planned capital expenditures, depends on our ability to generate cash flow. To some extent, this is subject to general economic, financial, competitive, legislative, regulatory and other factors that are beyond our

control. In addition, our ability to borrow additional funds under our subsidiaries' credit facilities will in some instances depend in part on our subsidiaries' ability to maintain specified financial ratios and satisfy certain financial covenants contained in the applicable credit agreements. In this regard, we currently believe it is probable one of our required financial ratios of our European credit facility will not be maintained at some point during 2009 most likely commencing at March 31, 2009. See "Management's Discussion and Analysis of Financial Condition and Results of Operations - Liquidity - Outstanding Debt Obligations and Borrowing Availability."

Our business may not generate sufficient cash flows from operating activities to allow us to pay our debts when they become due and to fund our other liquidity needs. As a result, we may need to refinance all or a portion of our debt before maturity. We may not be able to refinance any of our debt in a timely manner on favorable terms, if at all in the current credit markets. Any inability to generate sufficient cash flows or to refinance our debt on favorable terms could have a material adverse effect on our financial condition.

ITEM 1B. UNRESOLVED STAFF COMMENTS

None.

ITEM 2. PROPERTIES

We along with our subsidiaries: Kronos, CompX, WCS and NL lease office space for our principal executive offices in Dallas, Texas. A list of operating facilities for each of our subsidiaries is described in the applicable business sections of Item 1 - "Business." We believe our facilities are generally adequate and suitable for their respective uses.

ITEM 3. LEGAL PROCEEDINGS

We are involved in various legal proceedings. In addition to information included below, certain information called for by this Item is included in Note 17 to our Consolidated Financial Statements, which is incorporated herein by reference.

Lead Pigment Litigation - NL

NL's former operations included the manufacture of lead pigments for use in paint and lead-based paint. NL, other former manufacturers of lead pigments for use in paint and lead-based paint (together, the "former pigment manufacturers") and the Lead Industries Association ("LIA"), which discontinued business operations in 2002, have been named as defendants in various legal proceedings seeking damages for personal injury, property damage and governmental expenditures allegedly caused by the use of lead-based paints. Certain of these actions have been filed by or on behalf of states, counties, cities or their public housing authorities and school districts, and certain others have been asserted as class actions. These lawsuits seek recovery under a variety of theories, including public and private nuisance, negligent product design, negligent failure to warn, strict liability, breach of warranty, conspiracy/concert of action, aiding and abetting, enterprise liability, market share or risk contribution liability, intentional tort, fraud and misrepresentation, violations of state consumer protection statutes, supplier negligence and similar claims.

The plaintiffs in these actions generally seek to impose on the defendants responsibility for lead paint abatement and health concerns associated with the use of lead-based paints, including damages for personal injury, contribution and/or indemnification for medical expenses, medical monitoring expenses and costs for educational programs. To the extent the

plaintiffs seek compensatory or punitive damages in these actions, such damages are generally unspecified. In some cases, the damages are unspecified pursuant to the requirements of applicable state law. A number of cases are inactive or have been dismissed or withdrawn. Most of the remaining cases are in various pre-trial stages. Some are on appeal following dismissal or summary judgment rulings in favor of either the defendants or the plaintiffs. In addition, various other cases are pending (in which we are not a defendant) seeking recovery for injury allegedly caused by lead pigment and lead-based paint. Although we are not a defendant in these cases, the outcome of these cases may have an impact on cases that might be filed against us in the future.

We believe that these actions are without merit, and we intend to continue to deny all allegations of wrongdoing and liability and to defend against all actions vigorously. We have never settled any of these cases, nor have any final, non-appealable, adverse judgments against us been entered.

In September 1999, an amended complaint was filed in *Thomas v. Lead Industries Association, et al.* (Circuit Court, Milwaukee, Wisconsin, Case No. 99-CV-6411) adding as defendants the former pigment manufacturers to a suit originally filed against plaintiff's landlords. Plaintiff, a minor, alleged injuries purportedly caused by lead on the surfaces of premises in homes in which he resided and sought compensatory and punitive damages. The case was tried in October 2007, and in November 2007 the jury returned a verdict in favor of all defendants. In April 2008, plaintiff filed an appeal, and in February 2009, the appeal was stayed after the appellate court received notice that one of the defendants, Millennium Chemicals, Inc., had filed for bankruptcy.

In April 2000, we were served with a complaint in *County of Santa Clara v. Atlantic Richfield Company, et al.* (Superior Court of the State of California, County of Santa Clara, Case No. CV788657) brought against the former pigment manufacturers, the LIA and certain paint manufacturers. The County of Santa Clara seeks to recover compensatory damages for funds the plaintiffs have expended or will in the future expend for medical treatment, educational expenses, abatement or other costs due to exposure to, or potential exposure to, lead paint, disgorgement of profit, and punitive damages. Solano, Alameda, San Francisco, Monterey and San Mateo counties, the cities of San Francisco, Oakland, Los Angeles and San Diego, the Oakland and San Francisco unified school districts and housing authorities and the Oakland Redevelopment Agency have joined the case as plaintiffs. In January 2007, plaintiffs amended the complaint to drop all of the claims except for the public nuisance claim. In April 2007, the trial court ruled that the contingency fee arrangement between plaintiffs and their counsel was illegal. In May 2007, plaintiffs appealed the ruling and all proceedings in the trial court were stayed pending review by the appellate court. The appellate court reversed the trial court's ruling, thereby allowing contingent fee arrangements in the case. In May 2008, the defendants filed a petition for review by the California Supreme Court, which was granted in July 2008.

In June 2000, a complaint was filed in Illinois state court, *Lewis, et al. v. Lead Industries Association, et al.* (Circuit Court of Cook County, Illinois, County Department, Chancery Division, Case No. 00CH09800). Plaintiffs seek to represent two classes, one consisting of minors between the ages of six months and six years who resided in housing in Illinois built before 1978, and another consisting of individuals between the ages of six and twenty years who lived in Illinois housing built before 1978 when they were between the ages of six months and six years and who had blood lead levels of 10 micrograms/deciliter or more. The complaint seeks damages jointly and severally from the former pigment manufacturers and the LIA to establish a medical screening fund for the first class to determine blood lead levels, a medical monitoring fund for the second class to detect the onset of latent

diseases, and a fund for a public education campaign. In April 2008, the trial court judge certified a class of children whose blood lead levels were screened venously between August 1995 and February 2008 and who had incurred expenses associated with such screening. Certain defendants filed a motion to decertify the class in January 2009. The case is proceeding in the trial court.

In May 2001, we were served with a complaint in *City of Milwaukee v. NL Industries, Inc. and Mautz Paint* (Circuit Court, Civil Division, Milwaukee County, Wisconsin, Case No. 01CV003066). Plaintiff sought compensatory and equitable relief for lead hazards in Milwaukee homes, restitution for amounts it has spent to abate lead and punitive damages. The case was tried in May and June 2007, and in June 2007, the jury returned a verdict in favor of NL. In December 2007, plaintiff filed a notice of appeal, and in November 2008, the appellate court affirmed the verdict. In December 2008, the plaintiff petitioned the Wisconsin Supreme Court for review.

In November 2003, we were served with a complaint in *Lauren Brown v. NL Industries, Inc., et al.* (Circuit Court of Cook County, Illinois, County Department, Law Division, Case No. 03L 012425). The complaint seeks damages against us and two local property owners on behalf of a minor for injuries alleged to be due to exposure to lead paint contained in the minor's residence. We have denied all allegations of liability. In January 2009, NL filed a motion for summary judgment seeking dismissal of the case. The case is proceeding in the trial court.

In January 2006, we were served with a complaint in *Hess, et al. v. NL Industries, Inc., et al.* (Missouri Circuit Court 22nd Judicial Circuit, St. Louis City, Cause No. 052-11799). Plaintiffs are two minor children who allege injuries purportedly caused by lead on the surfaces of the home in which they resided. Plaintiffs seek compensatory and punitive damages. We have denied all allegations of liability. The case is proceeding in the trial court.

In January and February 2007, we were served with several complaints, the majority of which were filed in Circuit Court in Milwaukee County, Wisconsin. In some cases, complaints have been filed elsewhere in Wisconsin. The plaintiffs are minor children who allege injuries purportedly caused by lead on the surfaces of the homes in which they reside. Plaintiffs seek compensatory and punitive damages. The defendants in these cases include us, American Cyanamid Company, Armstrong Containers, Inc., E.I. Du Pont de Nemours & Company, Millennium Holdings, LLC, Atlanta Richfield Company, The Sherwin-Williams Company, Conagra Foods, Inc. and the Wisconsin Department of Health and Family Services. In some cases, additional lead paint manufacturers and/or property owners are also defendants. Of the cases filed, five remain pending, four of the remaining cases have been removed to Federal court and all of the cases have been stayed. We have denied all liability in these cases.

In May 2007, we were served with a complaint in *State of Ohio, ex rel. Marc Dann Attorney General v. Sherwin-Williams Company et al* (U.S. District Court, Southern District of Ohio, Eastern Division, Case No. 2:08-cv-079). NL filed a motion to dismiss the claims in October 2008. In February 2009, the state voluntarily dismissed its complaint.

In October 2007, we were served with a complaint in *Jones v. Joaquin Coe et al.* (Superior Court of New Jersey, Essex County, Case No. ESX-L-9900-06). Plaintiff seeks compensatory and punitive damages for injuries purportedly caused by lead paint on the surfaces of the apartments in which he resided as a minor. Other defendants include three former owners of the apartment building at issue in this case. We have denied all liability. In October 2008, the complaint was amended to add as defendants, former owners of other

residences in which the plaintiff lived. The case is proceeding in the trial court.

In addition to the foregoing litigation, various legislation and administrative regulations have, from time to time, been proposed that seek to (a) impose various obligations on present and former manufacturers of lead pigment and lead-based paint with respect to asserted health concerns associated with the use of such products and (b) effectively overturn court decisions in which we and other pigment manufacturers have been successful. Examples of such proposed legislation include bills which would permit civil liability for damages on the basis of market share, rather than requiring plaintiffs to prove that the defendant's product caused the alleged damage, and bills which would revive actions barred by the statute of limitations. While no legislation or regulations have been enacted to date that are expected to have a material adverse effect on our consolidated financial position, results of operations or liquidity, the imposition of market share liability or other legislation could have such an effect.

Environmental Matters and Litigation

General - Our operations are governed by various environmental laws and regulations. Certain of our businesses are and have been engaged in the handling, manufacture use or disposal of substances or compounds that may be considered toxic or hazardous within the meaning of applicable environmental laws and regulations. As with other companies engaged in similar businesses, certain of our past and current operations and products have the potential to cause environmental or other damage. We have implemented and continue to implement various policies and programs in an effort to minimize these risks. Our policy is to maintain compliance with applicable environmental laws and regulations at all of our plants and to strive to improve our environmental performance. From time to time, we may be subject to environmental regulatory enforcement under U.S. and foreign statutes, the resolution of which typically involves the establishment of compliance programs. It is possible that future developments, such as stricter requirements of environmental laws and enforcement policies, could adversely affect our production, handling, use, storage, transportation, sale or disposal of such substances. We believe that all of our facilities are in substantial compliance with applicable environmental laws.

Certain properties and facilities used in our former operations, including divested primary and secondary lead smelters and former mining locations of NL, are the subject of civil litigation, administrative proceedings or investigations arising under federal and state environmental laws. Additionally, in connection with past disposal practices, we are currently involved as a defendant, potentially responsible party ("PRP") or both, pursuant to the Comprehensive Environmental Response, Compensation and Liability Act, as amended by the Superfund Amendments and Reauthorization Act ("CERCLA"), and similar state laws in various governmental and private actions associated with waste disposal sites, mining locations, and facilities we or our predecessors currently or previously owned, operated or were used by us or our subsidiaries, or their predecessors, certain of which are on the EPA's Superfund National Priorities List or similar state lists. These proceedings seek cleanup costs, damages for personal injury or property damage and/or damages for injury to natural resources. Certain of these proceedings involve claims for substantial amounts. Although we may be jointly and severally liable for these costs, in most cases we are only one of a number of PRPs who may also be jointly and severally liable. In addition, we are a party to a number of personal injury lawsuits filed in various jurisdictions alleging claims related to environmental conditions alleged to have resulted from our operations.

Environmental obligations are difficult to assess and estimate for numerous reasons including:

- complexity and differing interpretations of governmental regulations;
- number of PRPs and their ability or willingness to fund such allocation of costs;
- financial capabilities of the PRPs and the allocation of costs among them;
- solvency of other PRPs;
- multiplicity of possible solutions; and
- number of years of investigatory, remedial and monitoring activity required.

In addition, the imposition of more stringent standards or requirements under environmental laws or regulations, new developments or changes regarding site cleanup costs or allocation of costs among PRPs, solvency of other PRPs, the results of future testing and analysis undertaken with respect to certain sites or a determination that we are potentially responsible for the release of hazardous substances at other sites, could cause our expenditures to exceed our current estimates. Because we may be jointly and severally liable for the total remediation cost at certain sites, the amount for which we are ultimately liable for may exceed our accruals due to, among other things, the reallocation of costs among PRPs or the insolvency of one or more PRPs. We cannot assure you that actual costs will not exceed accrued amounts or the upper end of the range for sites for which estimates have been made, and we cannot assure you that costs will not be incurred for sites where no estimate presently can be made. Further, additional environmental matters may arise in the future. If we were to incur any future liability, this could have a material adverse effect on our consolidated financial position, results of operations and liquidity.

We record liabilities related to environmental remediation obligations when estimated future expenditures are probable and reasonably estimable. We adjust our environmental accruals as further information becomes available to us or circumstances change. We generally do not discount estimated future expenditures to their present value due to the uncertainty of the timing of the pay out. We recognize recoveries of remediation costs from other parties, if any, as assets when their receipt is deemed probable. At December 31, 2008, we had no receivables for recoveries.

We do not know and cannot estimate the exact time frame over which we will make payments for our accrued environmental costs. The timing of payments depends upon a number of factors including the timing of the actual remediation process; which in turn depends on factors outside of our control. At each balance sheet date, we estimate the amount of our accrued environmental costs we expect to pay within the next twelve months, and we classify this estimate as a current liability. We classify the remaining accrued environmental costs as a noncurrent liability.

NL - On a quarterly basis, NL evaluates the potential range of liability at sites where NL has been named as a PRP or defendant, including sites for which our wholly-owned environmental management subsidiary, NL Environmental Management Services, Inc. ("EMS") has contractually assumed our obligations. See Note 17 to our Consolidated Financial Statements. At December 31, 2008, we had accrued approximately \$50 million for those environmental matters related to NL that we believe are reasonably estimable. We believe that it is not possible to estimate the range of costs for certain sites. The upper end of the range of reasonably possible costs to us for sites for which we believe it is possible to estimate costs is approximately \$76 million, including the amount currently accrued. We have not discounted these estimates to present value.

At December 31, 2008, there are approximately 20 sites for which we are not currently able to estimate a range of costs. For these sites, generally the investigation is in the early stages, and we are unable to determine whether or not we actually had any association with the site, the nature of our responsibility, if any, for the contamination at the site and the extent of contamination at the site. The timing and availability of information on these sites is dependent on events outside of our control, such as when the party alleging liability provides information to us. At certain of these previously inactive sites, we have received general and special notices of liability from the EPA alleging that we, along with other PRPs, are liable for past and future costs of remediating environmental contamination allegedly caused by former operations conducted at the sites. These notifications may assert that we, along with other PRPs, are liable for past clean-up costs that could be material to us if we are ultimately found liable.

In December 2003, we were served with a complaint in *The Quapaw Tribe of Oklahoma et al. v. ASARCO Incorporated et al.* (United States District Court, Northern District of Oklahoma, Case No. 03-CII-846H(J)). The complaint alleges public nuisance, private nuisance, trespass, strict liability, deceit by false representation and was subsequently amended to assert claims under CERCLA against us, six other mining companies and the United States of America with respect to former operations in the Tar Creek mining district in Oklahoma. Among other things, the complaint seeks actual and punitive damages from defendants. We have moved to dismiss the complaint, asserted certain counterclaims and have denied all of plaintiffs' allegations. In February 2006, the court of appeals affirmed the trial court's ruling that plaintiffs waived their sovereign immunity to defendants' counter claim for contribution and indemnity. In December 2007, the court granted the defendants' motion to dismiss the Tribe's medical monitoring claims. In July 2008, the court granted the defendants' motion to dismiss the Tribe's CERCLA natural resources damages claim. In January 2009, the defendants filed a motion for partial summary judgment, seeking dismissal of certain plaintiffs' claims for lack of standing.

In February 2004, we were served in *Evans v. ASARCO* (United States District Court, Northern District of Oklahoma, Case No. 04-CV-94EA(M)), a purported class action on behalf of two classes of persons living in the town of Quapaw, Oklahoma: (1) a medical monitoring class of persons who have lived in the area since 1994, and (2) a property owner class of residential, commercial and government property owners. Four individuals are named as plaintiffs, together with the mayor of the town of Quapaw, Oklahoma, and the School Board of Quapaw, Oklahoma. Plaintiffs allege causes of action in nuisance and seek a medical monitoring program, a relocation program, property damages and punitive damages. We answered the complaint and denied all of plaintiffs' allegations. The trial court subsequently stayed all proceedings in this case pending the outcome of a class certification decision in another case that had been pending in the same U.S. District Court, a case from which we have been dismissed with prejudice.

In January 2006, we were served in *Brown et al. v. NL Industries, Inc. et al.* (Circuit Court Wayne County, Michigan, Case No. 06-602096 CZ). Plaintiffs, property owners and other past or present residents of the Krainz Woods Neighborhood of Wayne County, Michigan, allege causes of action in negligence, nuisance, trespass and under the Michigan Natural Resources and Environmental Protection Act with respect to a lead smelting facility formerly operated by us and another defendant. Plaintiffs seek property damages, personal injury damages, loss of income and medical expense and medical monitoring costs. In October 2007, we moved to dismiss several plaintiffs who failed to respond to discovery requests, and in February 2008, the motion was granted with respect to all such plaintiffs. In February 2008, the trial court entered a case management order pursuant to which the case will proceed

as to eight of the plaintiffs' claims, and the claims of the remaining plaintiffs have been stayed in the meantime. In April 2008, the other defendant in the case agreed to a settlement with the plaintiffs, and we are the only remaining defendant. The case is proceeding in the trial court.

In June 2008, we were served in *Barton, et al. v. NL Industries, Inc.*, (U.S. District Court, Eastern District of Michigan, Case No.: 2:08-CV-12558). In January 2009, we were served in *Brown, et al. v. NL Industries, Inc. et al.* (Circuit Court Wayne County, Michigan, Case No. 09-002458 CE). The plaintiffs in both of these cases are additional property owners and other past or present residents of the Krainz Woods Neighborhood, and the claims raised in these cases are identical to those in the *Brown* case described above. We intend to deny liability in both subsequent cases and will defend vigorously against all claims.

In June 2006, we and several other PRPs received a Unilateral Administrative Order ("UAO") from the EPA regarding a formerly-owned mine and milling facility located in Park Hills, Missouri. The Doe Run Company is the current owner of the site, purchased by a predecessor of Doe Run from us in approximately 1936. Doe Run is also named in the Order. In April 2008, the parties signed a definitive cost sharing agreement for sharing of the costs anticipated in connection with the order. In May 2008, the parties began work at the site as required by the UAO and in accordance with the cost sharing agreement.

In October 2006, we entered into a consent decree in the United States District Court for the District of Kansas, in which we agreed to perform remedial design and remedial actions in Operating Unit 6 of the Waco Subsite of the Cherokee County Superfund Site. We conducted milling activities on the portion of the site which we have agreed to remediate. We are also sharing responsibility with other PRPs as well as the EPA for remediating a tributary that drains the portions of the site in which the PRPs operated. We will also reimburse the EPA for a portion of its past and future response costs related to the site.

In June 2008, we received a Directive and Notice to Insurers from the New Jersey Department of Environmental Protection ("NJDEP") regarding the Margaret's Creek site in Old Bridge Township, New Jersey. NJDEP alleged that a waste hauler transported waste from one of our former facilities for disposal at the site in the early 1970s. We are involved in an ongoing dialogue with the NJDEP regarding the scope of the remedial activities that may be necessary at the site and the identification of other PRPs having potential liability for the site.

In September 2008, we received a Special Notice letter from the EPA for liability associated with the Tar Creek site and a demand for related past and relocation costs. NL responded with a good-faith offer to pay certain of the past costs and to complete limited work in the areas in which it operated, but declined to pay for other past costs and declined to pay for any relocation costs. NL is involved in an ongoing dialogue with the EPA regarding a potential settlement with the EPA.

See also Item 1 "*Regulatory and Environmental Matters.*"

Tremont - Prior to 2005, *Tremont*, another of our wholly-owned subsidiaries, entered into a voluntary settlement agreement with the Arkansas Department of Environmental Quality and certain other PRPs pursuant to which *Tremont* and the other PRPs would undertake certain investigatory and interim remedial activities at a former mining site partly operated by NL located in Hot Springs County, Arkansas. *Tremont* had entered into an agreement with Halliburton Energy Services, Inc. ("*Halliburton*"), another PRP for this site, which provides for, among other things, the interim sharing of remediation costs associated with the site pending a final allocation of costs through an agreed-upon procedure in arbitration, as further discussed below.

On December 9, 2005, Halliburton and DII Industries, LLC, another PRP of this site, filed suit in the United States District Court for the Southern District of Texas, Houston Division, Case No. H-05-4160, against NL, *Tremont* and certain of its subsidiaries, M-I, L.L.C., Milwhite, Inc. and Georgia-Pacific Corporation seeking:

- to recover response and remediation costs incurred at the site;
- a declaration of the parties' liability for response and remediation costs incurred at the site;
- a declaration of the parties' liability for response and remediation costs to be incurred in the future at the site; and
- a declaration regarding the obligation of *Tremont* to indemnify Halliburton and DII for costs and expenses attributable to the site.

On December 27, 2005, a subsidiary of *Tremont* filed suit in the United States District Court for the Western District of Arkansas, Hot Springs Division, Case No. 05-6089, against Georgia-Pacific, seeking to recover response costs it has incurred and will incur at the site. Subsequently, plaintiffs in the *Houston* litigation agreed to stay that litigation by entering into an amendment with NL, *Tremont* and its affiliates to the arbitration agreement previously agreed upon for resolving the allocation of costs at the site. The *Tremont* subsidiary subsequently also agreed with Georgia Pacific to stay the *Arkansas* litigation, and subsequently that matter was consolidated with the *Houston* litigation, where the court agreed to stay the plaintiffs' claims against *Tremont* and its subsidiaries, but denied *Tremont's* motions to dismiss and to stay the claims made by M-I, Milwhite and Georgia Pacific.

In June and September 2007, the arbitration panel chosen by the parties to address the issues in the *Houston* litigation discussed above returned decisions favorable to NL, *Tremont* and its affiliates. Among other things, the panel found that Halliburton and DII are obligated to indemnify *Tremont* and its affiliates (including NL) against all costs and expenses, including attorney fees, associated with any environmental remediation at the site, and other sites arising out of NL's former petroleum services business and ordered Halliburton to pay *Tremont* approximately \$10.0 million in cash in recovery of past investigation and remediation costs and legal expenses incurred by *Tremont* related to the site, plus any future remediation and legal expenses incurred after specified dates, together with post-judgment interest accruing after September 1, 2007. In October 2007, *Tremont* filed a motion with the court in the *Houston* litigation to confirm the arbitration panel's decisions, and Halliburton and DII filed a motion to vacate such decisions. A confirmation hearing was held in November 2007, and in March 2008 the court upheld and confirmed the arbitration panel's decisions. In April 2008, Halliburton and DII filed a notice of their appeal of the court's opinion confirming the arbitration awards to the United States Court of Appeals for the Fifth Circuit. In July 2008, the trial court issued a final judgment pursuant to its March 2008 confirmation, and required that Halliburton and DII post a supersedeas bond in the amount of \$14.3 million during the period of the appeal in order to stay enforcement of the monetary award in the judgment. The nonmonetary portion of the judgment has not been stayed. Also in July 2008, Halliburton and DII filed a motion with the trial court for a new trial or to alter or

amend its judgment, and the court subsequently denied such motion. In January 2009 Halliburton and DII filed a Motion for Relief from the Court's Confirmation Order and Partial Final Judgment pursuant to Fed.R.Civ.P.60(b) claiming that essential documents had been wrongfully withheld from the arbitration panel. Subsequently the Court of Appeals for the Fifth Circuit affirmed the lower court ruling and remanded the Rule 60(b) motion back to the trial court. In February 2009, the Court held a hearing on the motion. Tremont has received payment from Halliburton in the amount of \$11.8 million as partial payment of the monetary judgment against it subject to the outcome of the Rule 60(b) hearing by the court.

Tremont and its affiliates (including NL) have also filed counterclaims in the Houston litigation against Halliburton and DII for other similar remediation costs associated with NL and Tremont's former petroleum services sites which the panel also found were the obligations of Halliburton and DII. At the September 26, 2008 hearing the trial court judge agreed to sever these claims from Case No. 05-6089 and consolidate those claims into a Civil Action Case No. H-08-1063 also pending with the court. Due to the uncertain nature of the on-going legal proceedings we have not accrued a receivable at December 31, 2008 for the amounts awarded. Pending a final confirmation of the arbitration panel's decisions, Tremont has accrued for this site based upon the agreed-upon interim cost sharing allocation. Tremont has a nominal amount accrued at December 31, 2008 for the environmental remediation.

Other - We have also accrued approximately \$2.8 million at December 31, 2008 for other environmental cleanup matters. This accrual is near the upper end of the range of our estimate of reasonably possible costs for such matters.

Insurance Coverage Claims.

We are involved in certain legal proceedings with a number of our former insurance carriers regarding the nature and extent of the carriers' obligations to us under insurance policies with respect to certain lead pigment and asbestos lawsuits. In addition to information that is included below, we have included certain of the information called for by this Item in Note 17 to our Consolidated Financial Statements, and we are incorporating that information here by reference.

The issue of whether insurance coverage for defense costs or indemnity or both will be found to exist for our lead pigment and asbestos litigation depends upon a variety of factors, and we cannot assure you that such insurance coverage will be available. We have not considered any potential insurance recoveries for lead pigment or asbestos litigation matters in determining related accruals.

We have agreements with two former insurance carriers pursuant to which the carriers reimburse us for a portion of our lead pigment litigation defense costs and one carrier reimburses us for a portion of our asbestos litigation defense costs. We are not able to determine how much we will ultimately recover from these carriers for past defense costs incurred by us, because of certain issues that arise regarding which defense costs qualify for reimbursement. While we continue to seek additional insurance recoveries, we do not know if we will be successful in obtaining reimbursement for either defense costs or indemnity. We have not considered any additional potential insurance recoveries in determining accruals for lead pigment or asbestos litigation matters. Any additional insurance recoveries would be recognized when the receipt is probable and the amount is determinable.

We have settled insurance coverage claims concerning environmental claims with certain of our principal former carriers. We do not expect further material settlements relating to environmental remediation coverage.

ITEM 4. SUBMISSION OF MATTERS TO A VOTE OF SECURITY HOLDERS

None.

PART II

ITEM 5. MARKET FOR REGISTRANT'S COMMON EQUITY, RELATED STOCKHOLDER MATTERS AND ISSUER PURCHASES OR EQUITY SECURITIES

Common Stock and Dividends - Our common stock is listed and traded on the New York Stock Exchange (symbol: VHI). As of February 27, 2009, we had approximately 2,800 holders of record of our common stock. The following table sets forth the high and low closing per share sales prices for our common stock and dividends for the periods indicated. On February 27, 2009 the closing price of our common stock was \$12.49.

	<u>High</u>	<u>Low</u>	<u>Cash dividends paid</u>
<i>Year ended December 31, 2007</i>			
First Quarter	\$31.32	\$13.20	\$.10
Second Quarter	19.56	14.90	.10
Third Quarter	25.15	15.44	.10
Fourth Quarter	26.69	15.94	.10
<i>Year ended December 31, 2008</i>			
First Quarter	\$23.70	\$14.14	\$.10
Second Quarter	31.24	24.21	.10
Third Quarter	27.64	14.04	.10
Fourth Quarter	17.31	6.80	.10
<i>First Quarter 2009 through February 27</i>	\$15.48	\$11.60	\$.10

We paid regular quarterly cash dividends of \$.10 per share during 2007 and 2008. In February 2009, our board of directors declared a first quarter 2009 dividend of \$.10 per share, to be paid on March 31, 2009 to shareholders of record as of March 10, 2009. In addition to our regular dividend, in March 2007 we paid a special dividend to our shareholders in the form of shares of TIMET common stock. In the special dividend we distributed approximately 56.8 million shares of TIMET common stock, which amount represented all of the TIMET common stock we owned at that date and approximately 35.1% of the outstanding TIMET common stock. See Note 3 to our Consolidated Financial Statements. However, declaration and payment of future dividends, and the amount thereof, is discretionary and is dependent upon our results of operations, financial condition, cash requirements for our businesses, contractual requirements and restrictions and other factors deemed relevant by our Board of Directors. The amount and timing of past dividends is not necessarily indicative of the amount or timing of any future dividends which we might pay. In this regard, our revolving bank credit facility currently limits the amount of our quarterly cash dividends to \$.10 per share, plus an additional aggregate amount of \$193.0 million at December 31, 2008.

Performance Graph - Set forth below is a line graph comparing the yearly change in our cumulative total stockholder return on our common stock against the cumulative total return of the S&P 500 Composite Stock Price Index and the S&P 500 Industrial Conglomerates Index for the period from December 31, 2003 through December 31, 2008. The graph shows the value at December 31 of each year assuming an original investment of \$100 at December 31, 2003, and assumes the reinvestment of our regular quarterly cash dividends in shares of our stock and the sale of the TIMET shares distributed in our special dividend with the proceeds also reinvested in our stock.

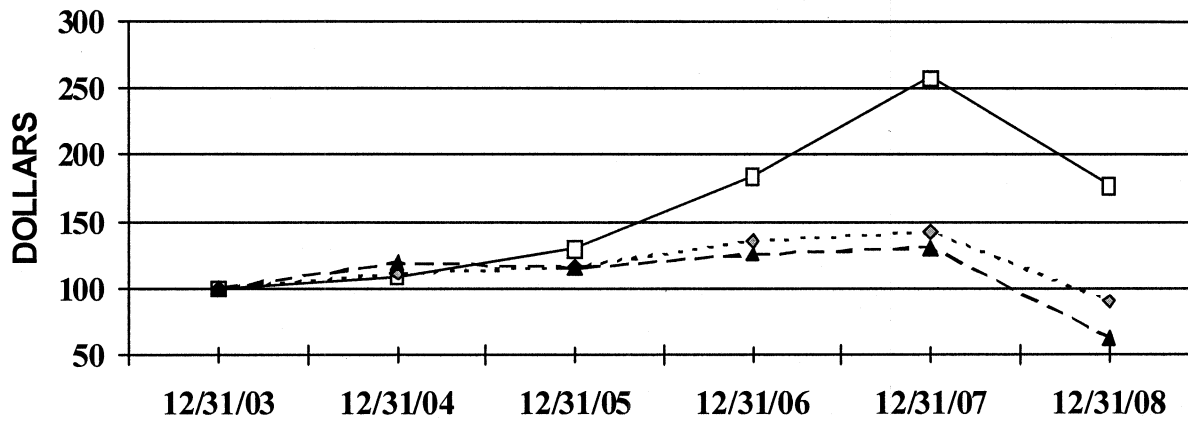

—□— Valhi, Inc. --◇-- S&P 500 Composite Stock Price Index -▲- S&P 500 Industrial Conglomerates Index

	December 31,					
	2003	2004	2005	2006	2007	2008
Valhi common stock	\$100	\$109	\$129	\$184	\$258	\$177
S&P 500 Composite Stock Price Index	100	111	116	135	142	90
S&P 500 Industrial Conglomerates Index	100	119	115	125	130	63

The information contained in the performance graph shall not be deemed "soliciting material" or "filed" with the SEC, or subject to the liabilities of Section 18 of the Securities Exchange Act, as amended, except to the extent we specifically request that the material be treated as soliciting material or specifically incorporate this performance graph by reference into a document filed under the Securities Act or the Securities Exchange Act.

Equity Compensation Plan Information - We have an equity compensation plan, which was approved by our stockholders, which provides for the discretionary grant to our employees and directors of, among other things, options to purchase our common stock and stock awards. As of December 31, 2008 there were 295,000 options outstanding to purchase shares of our common stock, and approximately 4.0 million shares of our common stock were available for future grants or issuance. We do not have any equity compensation plans that were not approved by our stockholders. See Note 14 to the Consolidated Financial Statements.

Treasury Stock Purchases - In March 2005, our board of directors authorized the repurchase of up to 5.0 million shares of our common stock in open market transactions, including block purchases, or in privately negotiated transactions, which may include transactions with our affiliates. In November 2006, our board of directors authorized the repurchase of an additional 5.0 million shares. We may purchase the stock from time to time as market conditions permit. The stock repurchase program does not include specific price targets or timetables and may be suspended at any time. Depending on market conditions, we could terminate the program prior to completion. We will use our cash on hand to acquire the shares. Repurchased shares will be retired and cancelled or may be added to our treasury stock and used for employee benefit plans, future acquisitions or other corporate purposes. See Note 14 to the Consolidated Financial Statements.

In December 2008, our consolidated subsidiary NL, purchased shares of our common stock in open market transactions. Under Delaware Corporation Law, 100% (and not the proportionate interest) of a parent company's shares held by a majority-owned subsidiary of the parent is considered to be treasury stock.

The following table discloses certain information regarding the shares of our common stock by NL in December 2008 (the only treasury stock purchases during the fourth quarter of 2008).

<u>Period</u>	<u>Total number of shares purchased</u>	<u>Average price paid per share, including commissions</u>	<u>Total number of shares purchased as part of a publicly-announced plan</u>	<u>Maximum number of shares that may yet be purchased under the publicly-announced plan at end of period</u>
December 1, 2008 to December 31, 2008	79,017	\$13.68	- 0 -	4,006,600

ITEM 6. SELECTED FINANCIAL DATA

The following selected financial data has been derived from our audited Consolidated Financial Statements. The following selected financial data should be read in conjunction with our Consolidated Financial Statements and related Notes and Item 7 - "Management's Discussion and Analysis of Financial Condition and Results of Operations."

	<u>Years ended December 31,</u>				
	<u>2004</u>	<u>2005</u>	<u>2006</u>	<u>2007</u>	<u>2008</u>
	(In millions, except per share data)				
STATEMENTS OF OPERATIONS DATA:					
Net sales:					
Chemicals	\$1,128.6	\$1,196.7	\$1,279.5	\$1,310.3	\$1,316.9
Component products	182.6	186.3	190.1	177.7	165.5
Waste management	8.9	9.8	11.8	4.2	2.9
Total net sales	<u>\$1,320.1</u>	<u>\$1,392.8</u>	<u>\$1,481.4</u>	<u>\$1,492.2</u>	<u>\$1,485.3</u>
Operating income (loss):					
Chemicals	\$ 102.4	\$ 165.6	\$ 138.1	\$ 88.6	\$ 52.0
Component products	16.2	19.3	20.6	16.0	5.5
Waste management	(10.2)	(12.1)	(9.5)	(14.1)	(21.5)
Total operating income	<u>\$ 108.4</u>	<u>\$ 172.8</u>	<u>\$ 149.2</u>	<u>\$ 90.5</u>	<u>\$ 36.0</u>
Equity in earnings of TIMET	<u>\$ 22.7</u>	<u>\$ 64.9</u>	<u>\$ 101.1</u>	<u>\$ 26.9</u>	<u>\$ -</u>
Income (loss) from continuing operations	\$ 225.5	\$ 82.1	\$ 141.7	\$ (45.7)	\$ (.8)
Discontinued operations	3.7	(.2)	-	-	-
Net income (loss)	<u>\$ 229.2</u>	<u>\$ 81.9</u>	<u>\$ 141.7</u>	<u>\$ (45.7)</u>	<u>\$ (.8)</u>
DILUTED EARNINGS PER SHARE DATA:					
Income (loss) from continuing operations	\$ 1.87	\$.69	\$ 1.20	\$ (.40)	\$ (.01)
Net income (loss)	\$ 1.90	\$.69	\$ 1.20	\$ (.40)	\$ (.01)
Cash dividends	\$.24	\$.40	\$.40	\$.40	\$.40
Weighted average common shares outstanding	120.4	118.5	116.5	114.7	114.4
STATEMENTS OF CASH FLOW DATA:					
Cash provided by (used in):					
Operating activities	\$ 142.1	\$ 104.3	\$ 86.3	\$ 63.5	\$ (24.5)
Investing activities	(58.1)	20.4	(89.5)	(65.4)	(60.9)
Financing activities	78.4	(115.8)	(87.6)	(56.1)	(12.0)
BALANCE SHEET DATA (at year end):					
Total assets ⁽¹⁾	\$2,690.5	\$2,578.4	\$2,804.7	\$2,603.0	\$2,389.4
Long-term debt	769.5	715.8	785.3	889.8	911.0
Stockholders' equity ⁽¹⁾⁽²⁾	876.1	797.3	866.8	618.4	468.8

(1) We adopted the asset and liability recognition provisions of Statement of Financial Accounting Standard ("SFAS") No. 158 as of December 31, 2006 and the measurement date provisions of SFAS No. 158 as of December 31, 2007. See Notes 11 and 18 to our Consolidated Financial Statements.

(2) We adopted FASB Interpretation Number ("FIN") 48 as of January 1, 2007. See Note 18 to our Consolidated Financial Statements.

ITEM 7. MANAGEMENT'S DISCUSSION AND ANALYSIS OF FINANCIAL CONDITION AND RESULTS OF OPERATIONS

RESULTS OF OPERATIONS

Business Overview

We are primarily a holding company. We operate through our wholly-owned and majority-owned subsidiaries, including NL Industries, Inc., Kronos Worldwide, Inc., CompX International, Inc., Tremont LLC and Waste Control Specialists LLC ("WCS"). Prior to March 26, 2007 we were the largest shareholder of Titanium Metals Corporation ("TIMET") although we owned less than a majority interest. Kronos (NYSE: KRO), NL (NYSE: NL) and CompX (NYSE: CIX) each file periodic reports with the SEC.

We have three consolidated operating segments:

- *Chemicals* - Our chemicals segment is operated through our majority ownership of Kronos. Kronos is a leading global producer and marketer of value-added titanium dioxide pigments ("TiO₂"). TiO₂ is used for a variety of manufacturing applications, including plastics, paints, paper and other industrial products.
- *Component Products* - We operate in the component products industry through our majority ownership of CompX. CompX is a leading global manufacturer of security products, precision ball bearing slides and ergonomic computer support systems used in the office furniture, transportation, postal, tool storage, appliance and a variety of other industries. CompX is also a leading manufacturer of stainless steel exhaust systems, gauges and throttle controls for the performance marine industry.
- *Waste Management* - WCS is our wholly-owned subsidiary which owns and operates a West Texas facility for the processing, treatment, storage and disposal of hazardous, toxic and certain types of low-level radioactive waste. WCS obtained a byproduct disposal license in 2008 and is in the process constructing the byproduct disposal facility, which is expected to be operational in the second half of 2009. In January 2009 WCS received a low-level radioactive waste disposal permit, and construction of the low-level radioactive waste facility is currently expected to begin in the second quarter of 2009, following the completion of some pre-construction licensing and administrative matters, and is expected to be operational in the second quarter of 2010.

On March 26, 2007 we completed a special dividend of the TIMET common stock we owned to our stockholders. We accounted for our 35% interest in TIMET by the equity method through March 31, 2007. As a result we now own approximately 1% of TIMET's outstanding common stock. Accordingly we now account for our shares of TIMET common stock as available-for-sale marketable securities carried at fair value. See Note 3 to the Consolidated Financial Statements. TIMET is a leading global producer of titanium sponge, melted products and milled products. Titanium is used for a variety of commercial, aerospace, military, medical and other emerging markets. TIMET is also the only titanium producer with major production facilities in both of the world's principal titanium markets: the U.S. and Europe.

Income (Loss) From Operations Overview

Year Ended December 31, 2007 Compared to Year Ended December 31, 2008 -

We reported a net loss of \$.8 million or \$.01 per diluted share in 2008 compared to a net loss of \$45.7 million, or \$.40 per diluted share, in 2007.

Our diluted earnings per share improved from 2007 to 2008 due primarily to the net effects of:

- an income tax charge recognized by our Chemicals Segment in 2007 primarily as a result of a reduction in German tax rates;
- ceasing to record equity in earnings from TIMET due to the distribution of our TIMET shares in the first quarter of 2007;
- an income tax charge recognized by our Chemicals Segment related to an adjustment of certain German tax attributes in 2007;
- an income tax benefit due to a net decrease in our reserve for uncertain tax positions in 2007;
- a litigation settlement gain in 2008 received by NL;
- lower operating income from each of our segments in 2008;
- a goodwill impairment recognized by our Component Products Segment in 2008;
- an income tax benefit recognized by our Chemicals Segment in 2008 related to a net reduction in our reserve for uncertain tax positions;
- an income tax charge recognized in 2008 due to a net increase in our reserve for uncertain tax positions; and
- interest income related to an escrow fund recognized by NL in 2008.

Our net loss in 2007 includes (net of tax and minority interest):

- a charge of \$.52 per diluted share as a result of the effect of a reduction of the German income tax rates in 2007;
- a charge of \$.05 per diluted share related to the adjustment of certain German tax attributes within our Chemicals Segment;
- an income tax benefit of \$.03 per diluted share due to a net decrease in our reserve for uncertain tax positions; and
- income of \$.03 per diluted share related to certain insurance recoveries recognized by NL.

Our net loss in 2008 includes (net of tax and minority interest):

- income of \$.23 per diluted share related to a litigation settlement gain received by NL;
- income of \$.04 per diluted share related to the adjustment of certain German income tax attributes within our Chemicals Segment;
- income of \$.04 per diluted share related to certain insurance recoveries we recognized;
- interest income of \$.02 per diluted share related to certain escrow funds held for the benefit of NL;
- a charge of \$.06 per diluted share related to goodwill impairment recognized on the Marine Components reporting unit of our Component Products Segment; and
- a charge of \$.05 per diluted share due to a net increase in our reserve for uncertain tax positions.

We discuss these amounts more fully below.

Year Ended December 31, 2006 Compared to Year Ended December 31, 2007 -

We reported a net loss of \$45.7 million or \$.40 per diluted share in 2007 compared to income of \$141.7 million, or \$1.20 per diluted share, in 2006.

Our diluted earnings per share decreased from 2006 to 2007 due primarily to the net effects of:

- an income tax charge recognized by our Chemicals Segment in 2007 primarily as a result of a reduction in German tax rates;
- an income tax benefit due to a net decrease in our reserve for uncertain tax positions in 2007;
- a lower effective income tax rate in 2006 primarily due to the favorable resolution in 2006 of audits in our Chemicals Segment's operations in Germany, Belgium and Norway;
- ceasing to record equity in earnings from TIMET due to the distribution of our TIMET shares in the first quarter of 2007;
- the gain in 2006 from the sale of certain land in Nevada;
- lower operating income from each of our segments in 2007;
- a charge in 2006 from the redemption of our 8.875% Senior Secured Notes;
- lower interest expense in 2007 resulting from the April 2006 refinancing of our Senior Secured Notes; and
- lower dividend income from the Amalgamated Sugar Company, LLC in 2007 as the additional dividend it owed to us was completely paid in 2006.

Our net income in 2006 includes (net of tax and minority interest, as applicable):

- a net income tax benefit of \$.21 per diluted share at our Chemicals Segment related to the net effect of the withdrawal of certain income tax assessments previously made by Belgian and Norwegian tax authorities, the favorable resolution of certain income tax issues related to our German and Belgian operations and the enactment of a reduction in Canadian federal income tax rates offset by the unfavorable resolution of certain other income tax issues related to our German operations;
- income of \$.20 per diluted share related to the sale of certain of our land in Nevada;
- a charge related to the redemption of our 8.875% Senior Secured Notes of \$.09 per diluted share;
- a gain of \$.09 per diluted share related to TIMET's sale of its minority interest in VALTIMET, a manufacturing joint venture located in France; and
- income of \$.03 per diluted share related to certain insurance recoveries recognized by NL.

Our net loss in 2007 includes (net of tax and minority interest):

- a charge of \$.52 per diluted share as a result of the effect of a reduction of the German income tax rates in 2007;
- a charge of \$.05 per diluted share related to the adjustment of certain German tax attributes within our Chemicals Segment;
- an income tax benefit of \$.03 per diluted share due to a net decrease in our reserve for uncertain tax positions; and
- income of \$.03 per diluted share related to certain insurance recoveries recognized by NL.

We discuss these amounts more fully below.

Current Forecast for 2009 -

We currently expect to report a higher net loss for 2009 as compared to the net loss in 2008 primarily due to the net effects of:

- lower expected operating income from our Chemicals Segment due to anticipated higher production costs;
- recording a lower gain on litigation settlement in 2009; and
- lower operating losses at WCS as we expect more revenues with the completion of the byproduct disposal facility in the second quarter of 2009.

Critical accounting policies and estimates

We have based the accompanying "Management's Discussion and Analysis of Financial Condition and Results of Operations" upon our Consolidated Financial Statements. We prepare our Consolidated Financial Statements in accordance with accounting principles generally accepted in the United States of America ("GAAP"). In many cases the accounting treatment of a particular transaction does not require us to make estimates and judgments. However, in other cases we are required to make estimates and judgments that affect the reported amounts of assets and liabilities and disclosure of contingent assets and liabilities at the date of the financial statements, and the reported amounts of revenues and expenses during the reported period. On an on-going basis, we evaluate our estimates, including those related to impairments of investments in marketable securities and investments accounted for by the equity method, the recoverability of other long-lived assets (including goodwill and other intangible assets), pension and other postretirement benefit obligations and the underlying actuarial assumptions related thereto, the realization of deferred income and other tax assets and accruals for environmental remediation, litigation, income tax contingencies. We base our estimates on historical experience and on various other assumptions we believe are reasonable under the circumstances, the results of which form the basis for making judgments about the reported amounts of assets, liabilities, revenues and expenses. Actual results might differ significantly from previously-estimated amounts under different assumptions or conditions.

"Our critical accounting policies" relate to amounts having a material impact on our financial position and results of operations, and that require our most subjective or complex judgments. See Note 1 to our Consolidated Financial Statements for a detailed discussion of our significant accounting policies.

- *Marketable securities* - We own investments in certain companies that we account for as marketable securities carried at fair value or that we account for under the equity method. For these investments, we evaluate the fair value at each balance sheet date. We use quoted market prices, Level 1 inputs as defined in SFAS No. 157, to determine fair value for

certain of our marketable debt securities and publicly traded investees. For other of our marketable debt securities the fair value is generally determined using Level 2 inputs as defined in SFAS No. 157 because although these securities are traded in many cases the market is not active and the year end valuation is based on the last trade of the year which may be several days prior to December 31. We use Level 3 inputs to determine fair value of our investment in Amalgamated Sugar Company LLC. See Note 18 to our Consolidated Financial Statements. We record an impairment charge when we believe an investment has experienced an other than temporary decline in fair value below its cost basis (for marketable securities) or below its carrying value (for equity method investees). Further adverse changes in market conditions or poor operating results of underlying investments could result in losses or our inability to recover the carrying value of the investments that may not be reflected in an investment's current carrying value, thereby possibly requiring us to recognize an impairment charge in the future.

At December 31, 2008, the carrying value (which equals their fair value) of substantially all of our marketable securities equaled or exceeded the cost basis of each investment. Our investment in The Amalgamated Sugar Company LLC represents approximately 88% of the aggregate carrying value of all of our marketable securities at December 31, 2008. The \$250 million carrying value is equal to its cost basis, see Note 4 to our Consolidated Financial Statements. At December 31, 2008, the \$8.81 per share quoted market price of our investment in TIMET was almost two times our cost basis per share of our investment in TIMET.

- *Goodwill* - Our goodwill totaled \$396.8 million at December 31, 2008 resulting primarily from our various step acquisitions of Kronos and NL and to a lesser extent CompX's purchase of various businesses. In accordance with SFAS No. 142, *Goodwill and Other Intangible Assets*, we do not amortize goodwill.

We perform a goodwill impairment test annually in the third quarter of each year. Goodwill is also evaluated for impairment if the book value of its reporting unit exceeds its estimated fair value. A reporting unit can be a segment or an operating division based on the operations of the segment. For example, our Chemicals Segment produces a globally coordinated homogeneous product whereas our Component Products Segment operates as three distinct business units. For our Chemicals Segment, we use Level 1 inputs of publicly traded market prices to compare the book value to assess impairment. Because we test for goodwill at a reporting unit level for our Component Products Segment, we use Level 3 inputs of a discounted cash flow technique since Level 1 inputs of market prices are not available at the reporting unit level. If the fair value is less than the book value, the asset is written down to the estimated fair value.

Considerable management judgment is necessary to evaluate the impact of operating changes and to estimate future cash flows. Assumptions used in our impairment evaluations, such as forecasted growth rates and our cost of capital, are consistent with our internal projections and operating plans. However, different assumptions and estimates could result in materially different findings which could result in the recognition of a material goodwill impairment.

During the third quarter of 2008, our Component Products Segment determined that all of the goodwill associated with its marine components reporting unit was impaired. We recognized a \$10.1 million charge for the goodwill impairment, which represented all of the goodwill we had previously recognized for the Marine Components reporting unit of our Component Products Segment (including a nominal

amount of goodwill inherent in our investment in CompX). The factors that led us to conclude goodwill associated with the Marine Components reporting unit was fully impaired include the continued decline in consumer spending in the marine market as well as the overall negative economic outlook, both of which resulted in near-term and longer-term reduced revenue, profit and cash flow forecasts for the Marine Components unit. While we continue to believe in the long-term potential of the Marine Components reporting unit, due to the extraordinary economic downturn in the boating industry we are not currently able to foresee when the industry and our business will recover. In response to the present economic conditions, we have taken steps to reduce operating costs without inhibiting our ability to take advantage of opportunities to expand our market share.

When we performed this analysis in the third quarter of 2008, we also reviewed the goodwill associated with all of our other reporting units and concluded there was no impairment of the goodwill for those reporting units. Due to the continued weakening of the economy, we re-evaluated the goodwill associated with the furniture components reporting unit of our Component Products Segment again in the fourth quarter of 2008 and concluded no additional impairments were present.

If our future results were to be significantly below our current expectations, it is reasonably likely we would conclude additional impairments of the goodwill and intangible assets associated with the furniture components reporting unit would be present. As of December 31, 2008 our Furniture Components reporting unit had approximately \$10.6 million of goodwill, including goodwill inherent in our investment in CompX. Holding all other assumptions constant at the re-evaluation date, a 100 to 200 basis point increase in the discount rate would reduce the enterprise value for the furniture components reporting unit, indicating potential impairment. If we record additional impairment charges in the future, it could cause CompX to fail to comply with one or more of the financial covenants contained in its credit facility. See Note 9 to the Consolidated Financial Statements. In the event CompX were to fail to comply with one or more covenants, we would attempt to negotiate waivers of any noncompliance; however, there can be no assurance that we would be able to obtain any waivers. In addition the costs or conditions associated with any waivers could be significant. At December 31, 2008 CompX had no balances outstanding under the facility and it does not anticipate needing to utilize the facility for operations in 2009.

- *Long-lived assets* - We account for our long-lived assets, including our investment in WCS, in accordance with SFAS No. 144, *Accounting for the Impairment or Disposal of Long-Lived Assets*. We assess property, equipment and capitalized permit costs for impairment only when circumstances as specified in SFAS No. 144 indicate an impairment may exist. During 2008, as a result of continued operating losses, certain long-lived assets of our Waste Management Segment were evaluated for impairment as of December 31, 2008. WCS has had limited operations as it seeks regulatory approval for several licenses it needs for full scale operations. In January 2009, WCS received an order for the final license it needs to commence full scale operations. We have begun construction of the byproduct disposal facility which we expect to begin operations in the second quarter of 2009 and currently plan to commence construction of the low-level and mixed low-level site in the second half of 2009, following the completion of some pre-construction licensing and administrative matters. We estimate it will cost approximately \$70 million to construct this facility which will be incurred over the construction period from the second quarter of 2009 until the third quarter of 2010. Our impairment analysis is based on

estimated future undiscounted cash flows of WCS' operations, and this analysis indicated no impairment was present at December 31, 2008 and that the carrying value of WCS is recoverable as the aggregate future undiscounted cash flow estimate exceeded the carrying value of WCS' net assets by at least two times. Considerable management judgment is necessary to evaluate the impact of operating changes and to estimate future cash flows. Assumptions used in our impairment evaluations, such as when we will receive final regulatory licenses, the cost and timing of construction, forecasted growth rates and our cost of capital, are consistent with our internal projections and operating plans. However, different assumptions and estimates could result in materially different findings which could result in the recognition of a material asset impairment.

During the third quarter of 2008, as a result of the goodwill impairment discussed above, certain long-lived intangible assets of our Marine Component reporting segment were evaluated for impairment. This analysis indicated no impairment was present and that the carrying value of our Marine Components long-lived intangible assets, including customer lists, trademarks and patents, are recoverable as the estimated aggregate future undiscounted cash flows exceeds the carrying value of the assets. Assumptions used in our impairment evaluations, such as forecasted growth rates and our cost of capital, are consistent with our internal projections and operating plans. However, different assumptions and estimates could result in materially different findings which could result in the recognition of a material asset impairment.

No other long-lived assets in our other reporting units were tested for impairment during 2008 because there were no circumstances to indicate an impairment may exist at these units.

- *Employee benefit plan costs* - We provide a range of benefits including various defined benefit pension and other postretirement benefits for our employees. We record annual amounts related to these plans based upon calculations required by GAAP, which make use of various actuarial assumptions, such as: discount rates, expected rates of returns on plan assets, compensation increases, employee turnover rates, mortality rates and expected health care trend rates. We review our actuarial assumptions annually and make modifications to the assumptions based on current rates and trends when we believe appropriate. As required by GAAP, modifications to the assumptions are generally recorded and amortized over future periods. Different assumptions could result in the recognition of materially different expense amounts over different periods of times and materially different asset and liability amounts in our Consolidated Financial Statements. These assumptions are more fully described below under "Assumptions on defined benefit pension plans and OPEB plans."
- *Income taxes* - We recognize deferred taxes for future tax effects of temporary differences between financial and income tax reporting in accordance with SFAS 109, Accounting for Income Taxes. While we have considered future taxable income and ongoing prudent and feasible tax planning strategies in assessing the need for a deferred income tax asset valuation allowance, it is possible that in the future we may change our estimate of the amount of the deferred income tax assets that would more-likely-than-not be realized in the future. If such changes take place, there is a risk that an adjustment to our deferred income tax asset valuation allowance may be required that would either increase or decrease, as applicable, our reported net income in the period such change in estimate was made. For example, our Chemicals Segment has substantial net operating loss carryforwards in Germany (the equivalent of \$817 million for German corporate purposes and \$229 million for

German trade tax purposes at December 31, 2008). At December 31, 2008, we have concluded that no deferred income tax asset valuation allowance is required to be recognized with respect to such carryforwards, principally because (i) such carryforwards have an indefinite carryforward period, (ii) we have generated cumulative income in Germany over the most recent three-year period and consequently utilized a portion of such carryforwards during that period and (iii) we currently expect to utilize the remainder of such carryforwards over the long term. However, prior to the complete utilization of these carryforwards, particularly if the current economic downturn continues and we were to generate operating losses in our German operations for an extended period of time, it is possible we might conclude the benefit of the carryforwards would no longer meet the more-likely-than-not recognition criteria, at which point we would be required to recognize a valuation allowance against some or all of the then-remaining tax benefit associated with the carryforwards.

We also evaluate at the end of each reporting period whether some or all of the undistributed earnings of our foreign subsidiaries are permanently reinvested (as that term is defined in GAAP). While we may have concluded in the past that some undistributed earnings are permanently reinvested, facts and circumstances can change in the future, such as a change in the expectation regarding the capital needs of our foreign subsidiaries, could result in a conclusion that some or all of the undistributed earnings are no longer permanently reinvested. If our prior conclusions change, we would recognize a deferred income tax liability in an amount equal to the estimated incremental U.S. income tax and withholding tax liability that would be generated if all of such previously-considered permanently reinvested undistributed earnings were distributed to us. We did not change our conclusions on our undistributed foreign earnings in 2008.

Beginning in 2007, we record a reserve for uncertain tax positions in accordance with *FIN No. 48, Accounting for Uncertain Tax Positions*, for tax positions where we believe it is more-likely-than-not our position will not prevail with the applicable tax authorities. From time to time, tax authorities will examine certain of our income tax returns. Tax authorities may interpret tax regulations differently than we do. Judgments and estimates made at a point in time may change based on the outcome of tax audits and changes to or further interpretations of regulations, thereby resulting in an increase or decrease in the amount we are required to accrue for uncertain tax positions (and therefore a decrease or increase in our reported net income in the period of such change). Our reserve for uncertain tax positions changed during 2008. See Note 18 to our Consolidated Financial Statements.

- *Litigation and environmental liabilities* - We are involved in numerous legal and environmental actions in part due to NL's former involvement in the manufacture of lead-based products. In accordance with SFAS No. 5, *Accounting for Contingencies*, we record accruals for these liabilities when estimated future expenditures associated with such contingencies become probable, and we can reasonably estimate the amounts of such future expenditures. However, new information may become available to us, or circumstances (such as applicable laws and regulations) may change, thereby resulting in an increase or decrease in the amount we are required to accrue for such matters (and therefore a decrease or increase in our reported net income in the period of such change). At December 31, 2008 we have recorded total accrued environmental liabilities of \$52.9 million.

Operating income for each of our three operating segments is impacted by certain of these significant judgments and estimates, as summarized below:

- Chemicals - allowance for doubtful accounts, reserves for obsolete or unmarketable inventories, impairment of equity method investees, goodwill and other long-lived assets, defined benefit pension and OPEB plans and loss accruals,
- Component Products - reserves for obsolete or unmarketable inventories, impairment of goodwill and long-lived assets and loss accruals.
- Waste Management - impairment of long-lived assets and loss accruals.

In addition, general corporate and other items are impacted by the significant judgments and estimates for impairment of marketable securities and equity method investees, defined benefit pension and OPEB plans, deferred income tax asset valuation allowances and loss accruals.

***Segment Operating Results - 2007 Compared to 2008 and 2006 Compared to 2007 -
Chemicals -***

We consider TiO₂ to be a "quality-of-life" product, with demand affected by gross domestic product ("GDP") and overall economic conditions in our markets located in various regions of the world. Over the long-term, we expect demand for TiO₂ will grow by 2% to 3% per year, consistent with our expectations for the long-term growth in GDP. However, even if we and our competitors maintain consistent shares of the worldwide market, demand for TiO₂ in any interim or annual period may not change in the same proportion as the change in GDP, in part due to relative changes in the TiO₂ inventory levels of our customers. We believe our customers' inventory levels are partly influenced by their expectation for future changes in market TiO₂ selling prices. The majority of our TiO₂ grades and substantially all of our production are considered commodity pigment products, we compete for sales primarily on the basis of price.

The factors having the most impact on our reported operating results are:

- TiO₂ average selling prices;
- Currency exchange rates (particularly the exchange rate for the U.S. dollar relative to the euro, Norwegian krone and the Canadian dollar);
- TiO₂ sales and production volumes; and
- Manufacturing costs, particularly maintenance and energy-related expenses.

The key performance indicators for our Chemicals Segment are our TiO₂ average selling prices, and our level of TiO₂ sales and production volumes.

	Years ended December 31,			% Change	
	2006	2007	2008	2006-07	2007-08
	(Dollars in millions)				
Net sales	\$1,279.5	\$1,310.3	\$1,316.9	2 %	1 %
Cost of goods sold	980.8	1,062.2	1,098.7	8 %	3 %
Gross margin	\$ 298.7	\$ 248.1	\$ 218.2	(17)%	(12)%
Operating income	\$ 138.1	\$ 88.6	\$ 52.0	(36)%	(41)%
Percent of net sales:					
Cost of sales	77%	81%	83%		
Gross margin	23%	19%	17%		
Operating income	11%	7%	4%		
TiO ₂ operating statistics:					
Sales volumes*	511	519	478	1 %	(8)%
Production volumes*	516	512	514	(1)%	- %
Production rate as percent of capacity	Full	98%	97%		
Percent change in net sales:					
TiO ₂ product pricing				(4)%	2 %
TiO ₂ sales volumes				1 %	(8)%
TiO ₂ product mix				- %	2 %
Changes in currency exchange rates				5 %	5 %
Total				2 %	1 %

*Thousands of metric tons

Net Sales - Our Chemicals Segment's sales increased by 1% or \$6.6 million in 2008 compared to 2007 primarily due to a 5% favorable effect of fluctuations in foreign currency exchange rates, which increased sales by approximately \$61 million, and to a lesser extent a variations in grades of products sold favorably impacted net sales by 2%, along with a 2% increase in average TiO₂ selling prices. TiO₂ selling prices generally follow industry trends and prices will increase or decrease generally as a result of competitive market pressures. During the second and third quarters of 2008, we and our competitors announced various price increases and surcharges in response to higher operating costs. A portion of these increase announcements were implemented during the second, third and fourth quarters of 2008. The positive impact of currency, product mix and pricing in 2008 were almost entirely offset by an 8% decrease in sales volumes. Our sales volumes decreased primarily due to lower sales volumes in all markets as a result of a global weakening of demand due to poor overall economic conditions.

Our Chemicals Segment's sales increased by 2% or \$30.8 million in 2007 compared to 2006 due primarily to a 5% favorable effect of fluctuations in foreign currency exchange rates, which increased sales by approximately \$65 million, and to a lesser extent a 1% increase in TiO₂ sales volumes, offset by a 4% decline in average selling prices in 2007 as compared to 2006. Our Chemicals Segment's sales volumes in 2007 were a new record for us. The increase in our TiO₂ sales volumes in 2007 was due primarily to higher sales volumes in Europe and export markets, which were partially offset by lower sales volumes in North America.

Cost of Goods Sold - Our Chemicals Segment's cost of sales increased in 2008 primarily due to the impact of a 22%, or approximately \$27 million increase in utility costs (primarily energy), a 10% or approximately \$35 million increase in raw material costs and currency fluctuations (primarily the euro). Cost of sales as a percentage of sales increased in 2008 due to the net effects of higher operating costs and slightly higher average selling prices. Our operating rates were near full capacity in both periods.

Our Chemicals Segment's cost of sales increased in 2007 primarily due to the impact of higher sales volumes, lower utility costs, lower production volumes, and the effect of changes in currency exchange rates and higher operating costs. Cost of sales as a percentage of sales increased in 2007 due to the net effects of lower average selling prices, lower utility costs of approximately \$3 million, higher other manufacturing costs (including maintenance) of approximately \$5 million and slightly lower production volumes. TiO₂ production volumes decreased 1% for 2007 compared to the same period in 2006, which unfavorably impacted our operating income comparisons. Our operating rates were near full capacity in both periods.

Operating Income - Our Chemicals Segment's operating income declined in 2008 primarily due to the decline in gross margin and the effect of fluctuations in foreign currency exchange rates. The decline in operating income is driven by the decline in gross margin, which decreased to 17% in 2008 compared to 19% in 2007. While our average TiO₂ selling prices were higher in 2008, our gross margin decreased primarily because of lower sales volumes and higher manufacturing costs, which more than offset the impact of higher sales prices. Changes in currency rates have also negatively affected our gross margin. We estimate the negative effect of changes in currency exchange rates decreased operating income by approximately \$4 million when comparing 2008 to 2007.

Our Chemicals Segment's operating income declined in 2007 primarily due to the decrease in gross margin and the effect of fluctuations in currency exchange rates. The decline in operating income is driven by the decline in gross margin, which decreased to 19% in 2007 compared to 23% in 2006. While our sales volumes were higher in 2007, our gross margin decreased primarily because of lower average TiO₂ selling prices, lower production volumes and higher manufacturing costs, which more than offset the impact of higher sales volumes. Changes in currency rates have also negatively affected our gross margin. We estimate the negative effect of changes in currency exchange rates decreased operating income by approximately \$4 million when comparing 2007 to 2006.

Our Chemicals Segment's operating income is net of amortization of purchase accounting adjustments made in conjunction with our acquisitions of interests in NL and Kronos. As a result, we recognize additional depreciation expense above the amounts Kronos reports separately, substantially all of which is included within cost of goods sold. We recognized additional depreciation expense of \$13.2 million in 2006, \$3.6 million in 2007 and \$2.6 million in 2008, which reduced our reported Chemicals Segment's operating income as compared to amounts reported by Kronos. In the third quarter of 2006, certain of the basis differences became fully amortized, and as a result the amortization of our purchase accounting adjustments was lower in 2007 and 2008 as compared to 2006.

Currency Exchange Rates - Our Chemicals Segment has substantial operations and assets located outside the United States (primarily in Germany, Belgium, Norway and Canada). The majority of sales generated from our foreign operations are denominated in foreign currencies, principally the euro, other major European currencies and the Canadian dollar. A portion of our sales generated from our foreign operations are denominated in the U.S. dollar. Certain raw materials used worldwide, primarily titanium-containing feedstocks,

are purchased in U.S. dollars, while labor and other production costs are purchased primarily in local currencies. Consequently, the translated U.S. dollar value of our foreign sales and operating results are subject to currency exchange rate fluctuations, which may favorably or unfavorably impact reported earnings and may affect the comparability of period-to-period operating results. Overall, fluctuations in currency exchange rates had the following effects on our Chemicals Segment's net sales and operating income in 2008 and 2007 as compared to the respective prior year.

Increase (decrease) -	
Year ended December 31,	
<u>2006 vs. 2007</u>	<u>2007 vs. 2008</u>
(In millions)	

Impact on:

Net sales	\$65	\$61
Operating income	(4)	(4)

Other - On September 22, 2005, the chloride-process TiO₂ facility operated by our 50%-owned joint venture, Louisiana Pigment Company ("LPC"), temporarily halted production due to Hurricane Rita and as a result, both we and LPC filed claims with our insurers. We recognized a gain of \$1.8 million related to our business interruption claim in the fourth quarter of 2006, which is included in other income on our Consolidated Statement of Operations.

Outlook - We currently expect our Chemicals Segment's operating income will be lower in 2009 compared to 2008 primarily from higher production costs resulting in part from significantly reduced production volumes and the resulting unabsorbed fixed production costs and unfavorable currency effects.

In response to the worldwide economic slowdown and weak consumer confidence, we are significantly reducing our production volumes in 2009 in order to reduce our finished goods inventory and improve our liquidity. While overall industry pigment demand is expected to be lower in 2009 as compared to 2008 as a result of worldwide economic conditions, we currently expect our sales volumes in 2009 will be slightly higher as compared to 2008, as we expect to gain market share following anticipated reductions in industry capacity due to competitors' permanent plant shutdowns. We believe average selling prices in 2009 will decline from year-end levels during the first half of the year but will rise during the second half of 2009 which should result in slightly higher average worldwide TiO₂ selling prices for the year. To mitigate the negative impact of our significantly reduced production volumes, we are reducing our operating costs where possible, such as; reducing maintenance expenditures, research development expenditures and personnel costs.

Our expectations as to the future of the TiO₂ industry are based upon a number of factors beyond our control, including worldwide growth of gross domestic product, competition in the marketplace, solvency and continued operation of competitors, unexpected or earlier than expected capacity additions or reductions and technological advances. If actual developments differ from our expectations, our results of operations could be unfavorably affected.

We believe our annual attainable production capacity for 2009 is approximately 532,000 metric tons; however, we expect our production volumes in 2009 will be significantly lower than our attainable capacity, as indicated above. We currently expect we will operate at 75% to 85% of our attainable production capacity in 2009. Our expected capacity utilization levels could be adjusted upwards or downwards to match changes in demand for our product.

Component Products -

The key performance indicator for our Component Products Segment is operating income margin.

	<u>Years ended December 31,</u>			<u>% Change</u>	
	<u>2006</u>	<u>2007</u>	<u>2008</u>	<u>2006-07</u>	<u>2007-08</u>
	(Dollars in millions)				
Net sales	\$190.1	\$177.7	\$165.5	(7)%	(7)%
Cost of goods sold	<u>143.6</u>	<u>132.5</u>	<u>125.7</u>	(8)%	(5)%
Gross margin	<u>\$ 46.5</u>	<u>\$ 45.2</u>	<u>\$ 39.8</u>	(3)%	(12)%
Operating income	\$ 20.6	\$ 16.0	\$ 5.5	(22)%	(66)%
Percent of net sales:					
Cost of goods sold	76%	75%	76%		
Gross margin	24%	25%	24%		
Operating income	11%	9%	3%		

Net Sales - Our Component Product Segment's sales decreased in 2008 as compared to 2007 principally due to lower order rates from many of our customers resulting from unfavorable economic conditions in North America, offset in part by the effect of sales price increases for certain products to mitigate the effect of higher raw material costs.

Our Component Product Segment's sales decreased in 2007 as compared to 2006 primarily due to lower sales of certain products to the office furniture market where Asian competitors have established selling prices at a level below which we consider would return a minimally sufficient margin as well as lower order rates from many of our customers due to unfavorable economic conditions, offset in part by the effect of sales price increases for certain products to mitigate the effect of higher raw material costs.

Cost of Goods Sold - Our Component Products Segment's cost of sales increased as a percentage of sales in 2008 compared to 2007, and as a result gross margin decreased over the same period. Gross margin decreased primarily due to higher raw material costs, not all of which could be recovered through sales price increases or surcharges, combined with reduced coverage of fixed manufacturing costs from lower sales volume partially offset by lower depreciation expense in 2008 due to a reduction in capital expenditure requirements for shorter lived assets over the last several years in response to lower sales.

Our Component Products Segment's cost of goods sold decreased from 2006 to 2007, and gross margin percentage increased from the prior year. During 2007, we experienced the favorable effects of an improved product mix due to the sales decline primarily occurring in our lower margin Furniture Components reporting unit and improved operating efficiency within our recently acquired Marine Components reporting unit partially offset by the unfavorable effect of relative changes in foreign currency exchange rates, lower sales to the office furniture industry due to competition from lower priced Asian manufacturers and lower order rates from many of our customers due to unfavorable economic conditions.

Goodwill Impairment - During the third quarter of 2008, we recorded a goodwill impairment charge of \$10.1 million for the Marine Components reporting unit of our Component Products Segment. See Note 8 to the Consolidated Financial Statements.

Operating Income - Excluding the effects of the goodwill impairment charge our Component Products Segment's the comparison of operating income for 2008 to 2007 was primarily impacted by:

- a negative impact of approximately \$5.4 million relating to lower order rates from many of our customers resulting from unfavorable economic conditions in North America, and
- increased raw material costs that we were not able to fully recover through sales price increases by approximately \$1.0 million due to the competitive nature of the markets we serve.

The above decreases were primarily offset by:

- the one-time \$2.7 million of facility consolidation costs incurred in 2007;
- \$1.8 million in lower depreciation expense in 2008 due to a reduction in capital expenditures for shorter lived assets over the last several years in response to lower sales; and
- the \$1.3 million favorable effect on operating income of changes in foreign currency exchange rates.

Operating income for 2007 decreased compared to 2006 and operating margins decreased in 2007 compared to 2006. We experienced the favorable effects of an improved product mix due to:

- a higher portion of the sales decline in 2007 occurring among lower margin products;
- an increased percentage of sales from our higher margin Marine business; and
- improved operating efficiency within our recently acquired Marine operations.

However, these improvements were more than offset by the unfavorable effects of:

- the \$2.7 million one-time facility consolidation costs noted above;
- a \$2.4 million unfavorable effect of relative changes in foreign currency exchange rates (including the \$1.2 million related to foreign exchange transaction losses noted above);
- lower sales to the office furniture industry due to competition from lower priced Asian manufacturers; and
- lower order rates from many of our customers due to unfavorable economic conditions.

General - Our profitability primarily depends on our ability to utilize our production capacity effectively, which is affected by, among other things, the demand for our products and our ability to control our manufacturing costs, primarily comprised of labor costs and raw materials such as zinc, copper, coiled steel, stainless steel and plastic resins. Raw material costs represent approximately 51% of our total cost of sales. During 2006, 2007 and most of 2008, worldwide raw material costs increased significantly. We occasionally enter into raw material supply arrangements to mitigate the short-term impact of future increases in raw material costs. While these arrangements do not necessarily commit us to a minimum volume of purchases, they generally provide for stated unit prices based upon achievement of specified volume purchase levels. This allows us to stabilize raw material purchase prices to a certain extent, provided the specified minimum monthly purchase quantities are met. We enter into such arrangements for zinc, coiled steel and plastic resins. While raw material purchase prices have recently declined, it is uncertain whether the current prices will stabilize during 2009. Materials purchased on the spot

market are sometimes subject to unanticipated and sudden price increases. Due to the competitive nature of the markets served by our products, it is often difficult to recover increases in raw material costs through increased product selling prices or raw material surcharges. Consequently, overall operating margins may be affected by raw material cost pressures.

Foreign Currency Exchange Rates - Our Component Products Segment has substantial operations and assets located outside the United States in Canada and Taiwan. The majority of sales generated from our foreign operations are denominated in the U.S. dollar, with the rest denominated in foreign currencies, principally the Canadian dollar and the New Taiwan dollar. Most of our raw materials, labor and other production costs for our foreign operations are denominated primarily in local currencies. Consequently, the translated U.S. dollar values of our foreign sales and operating results are subject to currency exchange rate fluctuations which may favorably or unfavorably impact reported earnings and may affect comparability of period-to-period operating results. Overall, fluctuations in foreign currency exchange rates had the following effects on our Component Products Segment's sales and operating income in 2008 and 2007 as compared to the respective prior years.

Increase (decrease) -		
Year ended December 31,		
2006 vs. 2007	2007 vs. 2008	
(In millions)		

Impact on:

Net sales	\$.9	\$.4
Operating income	(2.4)	1.3

Outlook - Demand for our Component Products Segment's products continues to slow, especially during the fourth quarter of 2008, as customers react to the condition of the overall economy. While all reporting units of our Component Products Segment are being affected, we are experiencing a greater softness in demand in the industries we serve which are more directly connected to lower consumer spending, as further explained below.

- Our Security Products reporting unit is the least affected by the softness in consumer demand, because we sell products to a diverse number of business customers across a wide range of markets, most of which are not directly impacted by changes in consumer demand. While demand within this reporting unit is not as significantly affected by softness in the overall economy, we expect sales to be lower over the next twelve months.
- Our Furniture Components reporting unit sales are primarily concentrated in the office furniture, toolbox, home appliance and a number of other industries. Several of these industries, primarily toolbox and home appliance, are more directly affected by consumer demand than those served by our Security Products reporting unit. We expect many of the markets served by Furniture Components to continue to experience low demand over the next twelve months.
- Our Marine Component reporting unit has been the most affected by the slowing economy as the decrease in consumer confidence, the decline in home values, a tighter credit market and volatile fuel costs have resulted in a significant reduction in consumer spending in the marine market. We do not expect the marine market to recover until consumer confidence returns and home values stabilize.

While changes in market demand are not within our control, we are focused on the areas we can impact. We expect our lean manufacturing and cost improvement initiatives to continue to positively impact our productivity and result in a more efficient infrastructure that we can leverage when demand growth returns. Additionally, we continue to seek opportunities to gain market share in markets we currently serve, expand into new markets and develop new product features in order to mitigate the impact of reduced demand as well as broaden our sales base.

In addition to challenges with overall demand, volatility in the cost of raw materials is ongoing. While the cost of commodity raw materials declined in the second half of 2008, we currently expect these costs to continue to be volatile in 2009. If raw material prices increase, we may not be able to fully recover the cost by passing them on to our customers through price increases due to the competitive nature of the markets we serve and the depressed economic conditions.

Waste Management -

	<u>Years ended December 31,</u>		
	<u>2006</u>	<u>2007</u>	<u>2008</u>
	(In millions)		
Net sales	\$11.8	\$ 4.2	\$ 2.9
Cost of goods sold	<u>15.0</u>	<u>11.7</u>	<u>14.7</u>
Gross margin	<u>\$ (3.2)</u>	<u>\$ (7.5)</u>	<u>\$ (11.8)</u>
Operating loss	\$ (9.5)	\$ (14.1)	\$ (21.5)

General - We have operated WCS's waste management facility on a relatively limited basis while we navigated the regulatory licensing requirements to receive permits for the disposal of byproduct waste material and for a broad range of low-level and mixed low-level radioactive wastes ("LLRW"). We previously filed license applications for such disposal capabilities with the applicable Texas state agencies. In May 2008, the Texas Commission on Environmental Quality ("TCEQ") issued us a license for the disposal of byproduct material. Byproduct material includes uranium or thorium mill tailings as well as equipment, pipe and other materials used to handle and process the mill tailings. We began construction of the byproduct facility infrastructure at our site in Andrews County, Texas in the third quarter of 2008 and expect this facility to be complete in the second half of 2009. In January 2009, TCEQ issued a near-surface low-level and mixed LLRW disposal license to us. Construction of the LLRW site is currently expected to commence in the second quarter of 2009, following the completion of some pre-construction licensing and administrative matters, and is expected to be operational in the second quarter of 2010. While construction for byproduct and LLRW disposal facilities is still in progress, we currently have facilities that allow us to treat, store and dispose of a broad range of hazardous and toxic wastes and byproducts, and to treat and store a broad range of low-level and mixed LLRW.

Net Sales and Operating Loss - Our Waste Management Segment's sales decreased during 2008 compared to 2007, and our Waste Management operating loss increased, due to lower utilization of our waste management services, primarily because we have not been able to undertake new projects without the receipt of our pending licenses and completion of our new disposal facilities. Our Waste Management Segment's sales decreased during 2007 compared to 2006, and our Waste Management Segment's operating loss increased, due to lower utilization of our waste management services, primarily due to the completion in 2006 of a few projects that were not replaced with new business in 2007. We continue to seek to increase our Waste Management Segment's sales volumes from waste streams permitted under our current licenses.

Outlook - Having obtained the final regulatory license we need to commence full scale operations, we are in process of constructing the facilities we will need to provide "one-stop shopping" for hazardous, toxic, low-level and mixed LLRW and radioactive byproduct material. WCS will have the broadest range of capabilities of any commercial enterprise in the U.S. for the storage, treatment and permanent disposal of these materials which we believe will give WCS a significant and valuable competitive advantage in the industry once construction is complete in 2010. We are also exploring opportunities to obtain certain types of new business (including disposal and storage of certain types of waste) that, if obtained, could help to increase our Waste Management Segment's sales, and decrease our Waste Management Segment's operating loss, in 2009. Our ability to increase our Waste Management Segment's sales volumes through these waste streams, together with improved operating efficiencies through further cost reductions and increased capacity utilization, are important factors in improving our Waste Management operating results and cash flows. Until we are able to increase our Waste Management Segment's sales volumes, we expect we will continue to generally report operating losses in our Waste Management Segment. While achieving increased sales volumes could result in operating profits, we currently do not believe we will report any significant levels of Waste Management operating profit until we have started to generate revenues following completion of the construction discussed above.

We believe WCS can become a viable, profitable operations however, we do not know if we will be successful in improving WCS's cash flows. We have in the past, and we may in the future, consider strategic alternatives with respect to WCS. We could report a loss in any such strategic transaction.

Equity in earnings of TIMET - As discussed in Note 3 to the Consolidated Financial Statements, we completed a special dividend of our TIMET common stock on March 26, 2007. We now own approximately 1% of TIMET's common stock, and we account for our investment in TIMET's common stock as available-for-sale marketable securities carried at fair value. Prior to March 31, 2007, we accounted for our interest in TIMET by the equity method.

General Corporate Items, Interest Expense, Provision for Income Taxes, Minority Interest and Related Party Transactions

Interest and Dividend Income - A significant portion of our interest and dividend income in 2006, 2007 and 2008 relates to the distributions we received from The Amalgamated Sugar Company LLC. We recognized dividend income from the LLC of \$31.1 million in 2006 and \$25.4 million in each of 2007 and 2008.

In October 2005, we and Snake River amended the Company Agreement of the LLC pursuant to which, among other things, the LLC is required to make higher minimum levels of distributions to its members (including us) as compared to levels required under the prior Company Agreement. Under the new agreement, we should receive annually aggregate distributions from the LLC of approximately \$25.4 million. In addition, because certain specified

conditions were met during the 15-month period that commenced on October 1, 2005, the LLC was required to distribute to us an additional \$25 million during the 15-month period. This distribution is in addition to the \$25.4 million distribution noted above. We received approximately \$20 million of this additional amount in the fourth quarter of 2005, and the remaining \$6 million during 2006. We did not receive similar additional amounts during 2007 or 2008, nor do we expect to receive any additional amount during 2009. Therefore, we expect our interest and dividend income from the LLC in 2009 will be similar to the amount we received in 2008. See Notes 4 and 15 to our Consolidated Financial Statements. Interest income in the second quarter of 2008 also includes \$4.3 million earned on certain escrow funds of NL. Other general corporate interest and dividend income in 2009 is expected to be lower than 2008 due to lower expected balances available for investment and no additional interest from the escrow funds in 2009.

Insurance Recoveries - Insurance recoveries relate primarily to amounts NL received from certain of its former insurance carriers, and relate principally to the recovery of prior lead pigment and asbestos litigation defense costs incurred by NL. We have agreements with two former insurance carriers pursuant to which the carriers reimburse us for a portion of our past and future lead pigment litigation defense costs and one such carrier reimburses us for a portion of our asbestos litigation defense costs. The insurance recoveries in 2006, 2007 and 2008 include amounts we received from these carriers. We are not able to determine how much we will ultimately recover from the carriers for past defense costs incurred because of certain issues that arise regarding which defense costs qualify for reimbursement. Insurance recoveries in 2006 also include amounts we received for prior legal defense and indemnity coverage for certain of our environmental expenditures. We do not expect to receive any further material insurance settlements relating to environmental remediation matters.

While we continue to seek additional insurance recoveries for lead pigment and asbestos litigation matters, we do not know the extent to which we will be successful in obtaining reimbursement for either defense costs or indemnity. We have not considered any additional potential insurance recoveries in determining accruals for lead pigment litigation matters. Any additional insurance recoveries would be recognized when the receipt is probable and the amount is determinable. See Note 17 to our Consolidated Financial Statements.

Other General Corporate Income Items - The gain on disposal of fixed assets in 2006 relates to the sale of certain land in Nevada that was not associated with any of our operations. In the fourth quarter of 2008, we recognized a pre-tax gain of \$47.9 million related to the initial October 2008 closing contained in a settlement agreement related to condemnation proceedings on certain real property we owned in New Jersey. See Note 15 to our Consolidated Financial Statements.

Corporate Expenses, Net - Corporate expenses were \$32.9 million in 2008, \$4.7 million or 13% lower than in 2007. Included in 2008 corporate expense are:

- Litigation and related costs at NL of \$14.6 million in 2008 compared to \$22.1 in 2007; and
- Environmental expenses of \$6.5 million in 2008, compared to \$4.4 million in 2007.

Corporate expenses were \$37.6 million in 2007, \$4.6 million or 14%, higher than in 2006 primarily due to higher litigation and related expense. Included in 2007 corporate expenses are:

- Litigation and related costs at NL of \$22.1 million in 2007 compared to \$15.3 million in 2006; and
- Environmental expense of \$4.4 million in 2007, compared to \$4.0 million in 2006.

We expect that net general corporate expenses in 2009 will be higher than in 2008, primarily due to higher expected litigation and related expenses at NL as well as higher defined benefit pension plan expenses.

Obligations for environmental remediation costs are difficult to assess and estimate, and it is possible that actual costs for environmental remediation will exceed accrued amounts or that costs will be incurred in the future for sites in which we cannot currently estimate the liability. If these events were to occur during 2009, our corporate expenses would be higher than our current estimates. See Note 17 to our Consolidated Financial Statements.

Loss on Prepayment of Debt - In April 2006, we issued our euro 400 million aggregate principal amount of 6.5% Senior Secured Notes due 2013, and used the proceeds to redeem our euro 375 million aggregate principal amount of 8.875% Senior Secured Notes in May 2006. As a result of this prepayment, we recognized a \$22.3 million pre-tax interest expense charge in 2006, representing the call premium on the old Notes and the write-off of deferred financing costs and the existing unamortized premium on the old Notes. See Note 9 to our Consolidated Financial Statements. The annual interest expense on the new 6.5% Notes is approximately euro 6 million less than on the old 8.875% Notes.

Interest Expense - We have a significant amount of indebtedness denominated in the euro, primarily through our subsidiary Kronos International, Inc. ("KII"). From 2005 until May 2006, KII had euro 375 million aggregate principal amount of 8.875% Senior Secured Notes outstanding. KII has had euro 400 million aggregate principal amount of 6.5% Senior Secured Notes outstanding since April 2006. The interest expense we recognize on these fixed rate Notes will vary with fluctuations in the euro exchange rate. See also Item 7A, "Quantitative and Qualitative Disclosures About Market Risk."

Interest expense increased to \$68.7 million in 2008 from \$64.4 million in 2007 primarily due to unfavorable changes in currency exchange rates in 2008 compared to 2007, increased borrowings in 2008 (primarily under our European credit facility) and a full year of interest on the CompX note payable to TIMET which was \$2.2 million in 2008 compared to \$.6 million in 2007. The interest expense we recognize will vary with fluctuations in the euro exchange rate.

Interest expense decreased slightly to \$64.4 million in 2007 from \$67.6 million in 2006. Interest expense was lower in 2007 because we replaced the 8.875% Senior Secured Notes with 6.5% Senior Secured Notes during the second quarter of 2006 offset by the effect of having both notes outstanding during May 2006. This interest savings which was partially offset by unfavorable changes in currency exchange rates in 2007 compared to 2006. The interest expense we recognize on our Senior Secured Notes will vary with fluctuations in the euro exchange rate. In the fourth quarter of 2007, CompX issued to TIMET a \$52.6 million promissory note which bears interest at LIBOR plus 1%. See Note 9 to our Consolidated Financial Statements.

Assuming currency exchange rates do not change significantly from their current levels, we expect interest expense will be higher in 2009 as compared to 2008 due to higher expected debt levels in 2009

Provision for Income Taxes - We recognized income tax expense of \$63.8 million in 2006, \$103.2 million in 2007 and \$16.7 million in 2008. See Note 12 to our Consolidated Financial Statements for a tabular reconciliation of our statutory tax expense to our actual tax expense. Some of the more significant items impacting this reconciliation are summarized below.

Our provision for income taxes in 2008 includes:

- a \$7.2 million non-cash deferred income tax benefit related to a European Court ruling that resulted in the favorable resolution of certain income tax issues in Germany; and
- a charge of \$5.6 million due to an increase in our reserves for uncertain tax positions.

The provision does not include any benefit associated with the goodwill impairment charge (which is nondeductible for income tax purposes). This charge impacted the tax rate by \$3.5 million.

Our provision for income taxes in 2007 includes:

- a charge of \$87.4 million related to the reduction of our net deferred income tax asset in Germany resulting from the reduction in its income tax rates;
- a charge of \$8.7 million related to the adjustment of certain German income tax attributes; and
- a \$3.8 million benefit resulting from a net reduction in our reserve for uncertain tax positions.

Our provision for income tax in 2006 includes:

- an income tax benefit of \$21.7 million related to an increase in the amount of our German trade tax net operating loss carryforward, as a result of the resolution of certain income tax audits in Germany;
- an income tax benefit of \$10.4 million primarily resulting from the reduction in our income tax contingency reserves related to favorable developments of income tax audit issues in Belgium, Norway and Germany;
- an income tax benefit of \$1.4 million related to the favorable resolution of certain income tax audit issues in Germany and Belgium; and
- a \$1.3 million benefit resulting from the enactment of a reduction in Canadian income tax rates.

In addition, as discussed in Note 1 to our Consolidated Financial Statements, we recognize deferred income taxes with respect to the excess of the financial reporting carrying amount over the income tax basis of our direct investment in Kronos. The amount of such deferred income taxes can vary from period to period and have a significant impact on our overall effective income tax rate. The aggregate amount of such deferred income taxes included in our provision for income taxes was \$13.8 million in 2006, deferred income tax benefit of \$13.9 million in 2007 and our provision for income taxes in 2008 included deferred income tax expense of \$1.6 million associated with our investment in Kronos.

Minority Interest - Minority interest in after-tax earnings (losses) increased from a benefit of \$3.5 million in 2007 to a cost of \$5.7 million in 2008 due to net income at Kronos and NL in 2008 compared to their net losses in 2007 offset by lower net income at CompX.

Minority interest in after-tax net earnings (losses) declined from a cost of \$12.0 million in 2006 to a benefit of \$3.5 million in 2007 due to net losses at Kronos and NL and lower net income at CompX. During October 2007, our ownership interest in CompX increased to approximately 86%; and as a result our minority interest in CompX's earnings decreased beginning in the fourth quarter of 2007. See Notes 3 and 13 to the Consolidated Financial Statements.

Related Party Transactions - We are a party to certain transactions with related parties. See Note 16 to our Consolidated Financial Statements.

Assumptions on defined benefit pension plans and OPEB plans.

Defined Benefit Pension Plans. We maintain various defined benefit pension plans in the U.S., Europe and Canada. See Note 11 to our Consolidated Financial Statements. At December 31, 2008, the projected benefit obligations for all defined benefit plans comprised \$87.8 million related to U.S. plans and \$382.1 million related to foreign plans. Substantially, all of the projected benefit obligations attributable to foreign plans related to plans maintained by Kronos, and approximately 16%, 47% and 37% of the projected benefit obligations attributable to U.S. plans related to plans maintained by Kronos, NL, and Medite Corporation, a former business unit of Valhi (the "Medite plan").

We account for our defined benefit pension plans using SFAS No. 87, *Employer's Accounting for Pensions*, as amended by SFAS No. 158 effective December 31, 2006. Under SFAS No. 87, we recognize defined benefit pension plan expense and prepaid and accrued pension costs based on certain actuarial assumptions, principally the assumed discount rate, the assumed long-term rate of return on plan assets and the assumed increase in future compensation levels. Upon adoption of SFAS No. 158 effective December 31, 2006, we recognize the full funded status of our defined benefit pension plans as either an asset (for overfunded plans) or a liability (for underfunded plans) in our Consolidated Balance Sheet.

We recognized consolidated defined benefit pension plan expense of \$16.0 million in 2006, \$15.6 million in 2007 and \$1.9 million in 2008. The amount of funding requirements for these defined benefit pension plans is generally based upon applicable regulations (such as ERISA in the U.S.), and will generally differ from pension expense recognized under SFAS No. 87 for financial reporting purposes. In the fourth quarter of 2008 we recognized a \$6.9 million pension adjustment in connection with the correction of our pension expense previously recognized for 2006 and 2007 for our German pension plans (see Note 11 to our Consolidated Financial Statements). We made contributions to all of our defined benefit pension plans of \$28.1 million in 2006, \$28.0 million in 2007 and \$21.2 million in 2008.

The discount rates we utilize for determining defined benefit pension expense and the related pension obligations are based on current interest rates earned on long-term bonds that receive one of the two highest ratings given by recognized rating agencies in the applicable country where the defined benefit pension benefits are being paid. In addition, we receive advice about appropriate discount rates from our third-party actuaries, who may in some cases utilize their own market indices. We adjust these discount rates as of each valuation date (December 31st for all plans beginning in 2007) to reflect the then-current interest rates on such long-term bonds. We use these discount rates to determine the actuarial present value of the pension obligations as of December 31st of that year. We also use these discount rates to determine the interest component of defined benefit pension expense for the following year.

Approximately 65%, 15%, 13% and 3% of the projected benefit obligations attributable to plans maintained by Kronos at December 31, 2008 related to plans in Germany, Canada, Norway and the U.S., respectively. The Medite plan and NL's plans are all in the U.S. We use several different discount rate assumptions in determining our consolidated defined benefit pension plan obligations and expense because we maintain defined benefit pension plans in several different countries in North America and Europe and the interest rate environment differs from country to country.

We used the following discount rates for our defined benefit pension plans:

Discount rates used for:			
	Obligations at December 31, 2006 and expense in 2007	Obligations at December 31, 2007 and expense in 2008	Obligations at December 31, 2008 and expense in 2009
Kronos and NL plans:			
Germany	4.5%	5.5%	5.8%
Canada	5.0	5.3	6.5
Norway	4.8	5.5	5.8
U.S.	5.8	6.1	6.1
Medite plan	5.8	6.4	6.2

The assumed long-term rate of return on plan assets represents the estimated average rate of earnings we expect to be earned on the funds invested or to be invested in the plans' assets provided to fund the benefit payments inherent in the projected benefit obligations. Unlike the discount rate, which is adjusted each year based on changes in current long-term interest rates, the assumed long-term rate of return on plan assets will not necessarily change based upon the actual, short-term performance of the plan assets in any given year. Defined benefit pension expense each year is based upon the assumed long-term rate of return on plan assets for each plan and the actual fair value of the plan assets as of the beginning of the year. Differences between the expected return on plan assets for a given year and the actual return are deferred and amortized over future periods based either upon the expected average remaining service life of the active plan participants (for plans for which benefits are still being earned by active employees) or the average remaining life expectancy of the inactive participants (for plans for which benefits are not still being earned by active employees).

At December 31, 2008, the fair value of plan assets for all defined benefit plans comprised \$65.3 million related to U.S. plans and \$258.2 million related to foreign plans. Substantially all of such plan assets attributable to foreign plans related to plans maintained by Kronos, and approximately 17%, 47% and 36% of the plan assets attributable to U.S. plans related to plans maintained by Kronos, NL and the Medite plan, respectively. Approximately 57%, 19%, 17% and 4% of the plan assets attributable to plans maintained by Kronos at December 31, 2008 related to plans in Germany, Canada, Norway and the U.S., respectively. We use several different long-term rates of return on plan asset assumptions in determining our consolidated defined benefit pension plan expense because we maintain defined benefit pension plans in several different countries in North America and Europe, the plan assets in different countries are invested in a different mix of investments and the long-term rates of return for different investments differ from country to country.

In determining the expected long-term rate of return on plan asset assumptions, we consider the long-term asset mix (e.g. equity vs. fixed income) for the assets for each of its plans and the expected long-term rates of return for such asset components. In addition, we receive advice about appropriate long-term rates of return from our third-party actuaries. Such assumed asset mixes are summarized below:

- During 2008, substantially all of the Kronos, NL and Medite plan assets in the U.S. were invested in The Combined Master Retirement Trust ("CMRT"), a collective investment trust sponsored by Contran to permit the collective investment by certain master trusts that fund certain employee benefits plans sponsored by Contran and certain of its affiliates. Harold C. Simmons is the sole trustee of the CMRT. The CMRT's long-term investment objective is to provide a rate of return exceeding a composite of broad market equity and fixed income indices (including the S&P 500 and certain Russell indices), while utilizing both third-party investment managers as well as investments directed by Mr. Simmons. During the 20-year history of the CMRT through December 31, 2008, the average annual rate of return of the CMRT (excluding the CMRT's investment in TIMET common stock) has been 11%.
- In Germany, the composition of our plan assets is established to satisfy the requirements of the German insurance commissioner.
- In Canada, we currently have a plan asset target allocation of 60% to equity securities and 40% to fixed income securities, with an expected long-term rate of return for such investments to average approximately 125 basis points above the applicable equity or fixed income index.
- In Norway, we currently have a plan asset target allocation of 14% to equity securities, 64% to fixed income securities and the remainder primarily to cash and liquid investments. The expected long-term rate of return for such investments is approximately 9.0%, 5.0% and 4.0%, respectively.

Our pension plan weighted average asset allocations by asset category were as follows:

	<u>December 31, 2007</u>			
	<u>CMRT</u>	<u>Germany</u>	<u>Canada</u>	<u>Norway</u>
Equity securities and limited partnerships	98%	28%	60%	18%
Fixed income securities	-	49	34	68
Real estate	2	12	-	-
Cash, cash equivalents and other	-	11	6	14
Total	<u>100%</u>	<u>100%</u>	<u>100%</u>	<u>100%</u>

	<u>December 31, 2008</u>			
	<u>CMRT</u>	<u>Germany</u>	<u>Canada</u>	<u>Norway</u>
Equity securities and limited partnerships	68%	24%	53%	14%
Fixed income securities	29	52	39	83
Real estate	2	12	-	-
Cash, cash equivalents and other	1	12	8	3
Total	<u>100%</u>	<u>100%</u>	<u>100%</u>	<u>100%</u>

We regularly review our actual asset allocation for each of our plans, and will periodically rebalance the investments in each plan to more accurately reflect the targeted allocation when considered appropriate.

The assumed long-term rates of return on plan assets used for purposes of determining net period pension cost for 2006, 2007 and 2008 were as follows:

	<u>2006</u>	<u>2007</u>	<u>2008</u>
Kronos and NL plans:			
Germany	5.3%	5.8%	5.3%
Canada	7.0	6.8	6.3
Norway	6.5	5.5	6.1
U.S.	10.0	10.0	10.0
Medite plan	10.0	10.0	10.0

We currently expect to utilize the same long-term rates of return on plan asset assumptions in 2009 as we used in 2008 for purposes of determining our 2009 defined benefit pension plan expense.

To the extent that a plan's particular pension benefit formula calculates the pension benefit in whole or in part based upon future compensation levels, the projected benefit obligations and the pension expense will be based in part upon expected increases in future compensation levels. For all of our plans for which the benefit formula is so calculated, we generally base the assumed expected increase in future compensation levels on the average long-term inflation rates for the applicable country.

In addition to the actuarial assumptions discussed above, because Kronos maintains defined benefit pension plans outside the U.S., the amounts we recognize for defined benefit pension expense and prepaid and accrued pension costs will vary based upon relative changes in foreign currency exchange rates.

As discussed above, assumed discount rates and rates of return on plan assets are re-evaluated annually. A reduction in the assumed discount rate generally results in an actuarial loss, as the actuarially-determined present value of estimated future benefit payments will increase. Conversely, an increase in the assumed discount rate generally results in an actuarial gain. In addition, an actual return on plan assets for a given year that is greater than the assumed return on plan assets results in an actuarial gain, while an actual return on plan assets that is less than the assumed return results in an actuarial loss. Other actual outcomes that differ from previous assumptions, such as individuals living longer or shorter than assumed in mortality tables, which are also used to determine the actuarially-determined present value of estimated future benefit payments, changes in such mortality table themselves or plan amendments, will also result in actuarial losses or gains. Upon adoption of SFAS No. 158 effective December 31, 2006, these amounts are recognized in other comprehensive income. In addition, any actuarial gains generated in future periods would reduce the negative amortization effect included in earnings of any cumulative unrecognized actuarial losses, while any actuarial losses generated in future periods would reduce the favorable amortization effect included in earnings of any cumulative unrecognized actuarial gains.

During 2008, our defined benefit pension plans generated a net actuarial loss of \$81.6 million. This actuarial loss, resulted primarily from the general overall loss on plan assets in excess of the assumed return.

Based on the actuarial assumptions described above and our current expectations for what actual average foreign currency exchange rates will be during 2009, we currently expect our aggregate defined benefit pension expense will approximate \$18 million in 2009. In comparison, we currently expect to be required to make approximately \$18.6 million of aggregate contributions to such plans during 2009.

As noted above, defined benefit pension expense and the amounts recognized as prepaid and accrued pension costs are based upon the actuarial assumptions discussed above. We believe all of the actuarial assumptions used are reasonable and appropriate. If we had lowered the assumed discount rates by 25 basis points for all of their plans as of December 31, 2008, their aggregate projected benefit obligations would have increased by approximately \$15 million at that date, and their aggregate defined benefit pension expense would be expected to increase by approximately \$1 million during 2008. Similarly, if we lowered the assumed long-term rates of return on plan assets by 25 basis points for all of their plans, their defined benefit pension expense would be expected to increase by approximately \$1 million during 2009.

OPEB Plans. We provide certain health care and life insurance benefits for certain of our eligible retired employees. See Note 11 to our Consolidated Financial Statements. At December 31, 2008, approximately 39%, 29% and 32% of our aggregate accrued OPEB costs relate to Tremont, Kronos and NL, respectively. Kronos provides such OPEB benefits to retirees in the U.S. and Canada, and NL and Tremont provide such OPEB benefits to retirees in the U.S. We account for such OPEB costs under SFAS No. 106, *Employers Accounting for Postretirement Benefits other than Pensions*, as amended by SFAS No. 158. Under SFAS No. 106, OPEB expense and accrued OPEB costs are based on certain actuarial assumptions, principally the assumed discount rate and the assumed rate of increases in future health care costs. Upon adoption of SFAS No. 158 effective December 31, 2006, we recognize the full unfunded status of our OPEB plans as a liability.

We recognized consolidated OPEB expense of \$2.3 million in 2006, \$2.4 million in 2007 and \$2.2 million in 2008. Similar to defined benefit pension benefits, the amount of funding will differ from the expense recognized for financial reporting purposes, and contributions to the plans to cover benefit payments aggregated \$4.4 million in 2006, \$2.9 million in 2007 and \$2.7 million in 2008. Substantially all of our accrued OPEB costs relates to benefits being paid to current retirees and their dependents, and no material amount of OPEB benefits are being earned by current employees. As a result, the amount we recognize for OPEB expense for financial reporting purposes has been, and is expected to continue to be, significantly less than the amount of OPEB benefit payments we make each year. Accordingly, the amount of accrued OPEB costs we recognize has been, and is expected to continue to, decline gradually.

The assumed discount rates we utilize for determining OPEB expense and the related accrued OPEB obligations are generally based on the same discount rates we utilize for our U.S. and Canadian defined benefit pension plans.

In estimating the health care cost trend rate, we consider our actual health care cost experience, future benefit structures, industry trends and advice from third-party actuaries. In certain cases, NL has the right to pass on to retirees all or a portion of any increases in health care costs; for these retirees, any future increase in health care costs will have no effect on the amount of OPEB expense and accrued OPEB costs we recognize. During each of the past three years, we have assumed that the relative increase in health care costs will generally trend downward over the next several years, reflecting, among other things, assumed increases in efficiency in the health care system and industry-wide cost and plan-design cost containment initiatives. For example, at December 31, 2008, the expected rate of increase in future health care costs range is 5.5% to 8.5% in 2009, declining to a rate of 5.0% in 2015 and thereafter.

Based on the actuarial assumptions described above and Kronos' current expectation for what actual average foreign currency exchange rates will be during 2009, we expect our consolidated OPEB expense will approximate \$2 million in 2009. In comparison, we expect to be required to make approximately \$3.2 million of contributions to such plans during 2009.

As noted above, OPEB expense and the amount we recognize as accrued OPEB costs are based upon the actuarial assumptions discussed above. We believe all of the actuarial assumptions we use are reasonable and appropriate. If we had lowered the assumed discount rates by 25 basis points for all of our OPEB plans as of December 31, 2008, our aggregate projected benefit obligations would have increased by approximately \$.5 million at that date, our OPEB expense would be expected to be approximately the same during 2009. Similarly, if the assumed future health care cost trend rate had been increased by 100 basis points, our accumulated OPEB obligations would have increased by approximately \$2 million at December 31, 2008, and the change to OPEB expense would not be expected to be material.

Foreign Operations

We have substantial operations located outside the United States, principally Chemicals operations in Europe and Canada and Component Products operations in Canada and Taiwan. The functional currency of these operations is the local currency. As a result, the reported amount of our assets and liabilities related to these foreign operations will fluctuate based upon changes in currency exchange rates.

LIQUIDITY AND CAPITAL RESOURCES

Consolidated Cash Flows

Operating Activities -

Trends in cash flows from operating activities (excluding the impact of significant asset dispositions and relative changes in assets and liabilities) are generally similar to trends in our operating income.

Cash flows from our operating activities decreased from \$63.5 million provided by operating activities in 2007 to \$24.5 million used in operating activities in 2008. This \$88.0 million decrease in cash provided was due primarily to the net effects of the following items:

- lower consolidated operating income in 2008 of \$54.5 million, due to lower earnings across all of our segments, particularly at our Chemicals Segment;
- higher net cash used by changes in receivables, inventories, payables and accrued liabilities in 2008 of \$61.1 million, primarily due to relative changes in Kronos' inventory levels;
- higher cash paid for interest in 2007 of \$5.4 million, primarily as a result of the effects of currency exchange rates on the semiannual interest payments on our 6.5% Senior Secured Notes and higher average debt balances;
- lower cash paid for income taxes in 2008 of \$17.1 million primarily due to our lower earnings in 2008 as compared to 2007; and
- higher net distributions from our TiO₂ joint venture in 2008 of \$14.9 million due to relative changes in its cash requirements.

Cash flows provided by our operating activities decreased from \$86.3 million in 2006 to \$63.5 million in 2007. This \$22.8 million decrease in cash provided was due primarily to the net effects of the following items:

- lower consolidated operating income in 2007 of \$58.7 million, due to lower earnings across all of our segments, particularly at our Chemicals Segment;
- the \$20.9 million call premium we paid in 2006 when we prepaid our 8.85% Senior Secured Notes, which is required to be included in cash flows from operating activities;
- lower net cash used by changes in receivables, inventories, payables and accrued liabilities in 2007 of \$11.6 million, due primarily to relative changes in Kronos' inventory levels;
- lower cash paid for income taxes in 2007 of \$10.6 million due in part to the 2006 payment of certain income taxes associated with the settlement of prior year income tax audits; and
- higher net cash contributed to our TiO₂ joint venture which increased \$7.2 million in 2007 as compared to 2006.

Relative changes in working capital assets and liabilities can have a significant effect on cash flows from operating activities. Changes in working capital were affected by accounts receivable and inventory changes:

- Kronos' average days sales outstanding ("DSO") increased from 63 days at December 31, 2007 to 64 days at December 31, 2008, due to the timing of collection of accounts receivables balances at the end of 2008. CompX's average DSO decreased from 44 days at December 31, 2007 to 41 days at December 31, 2008 due to the timing of collections on a lower accounts receivable balance as of December 31, 2008
- Kronos' average number of days in inventory ("DII") increased from 59 days at December 31, 2007 to 113 days at December 31, 2008 as our sales

volumes decreased in 2008 (mostly in the fourth quarter) and our production volumes exceeded our TiO₂ sales volumes during the last half of 2008. CompX's average DII increased from 66 days at December 31, 2007 to 70 days at December 31, 2008 primarily due to lower sales in the fourth quarter of 2008 which impacted the DII calculation although in absolute terms, CompX reduced inventory by \$1.6 million from 2007 to 2008.

- Kronos' average days sales outstanding ("DSO") increased from 61 days at December 31, 2006 to 63 days at December 31, 2007, due to the timing of collection of higher accounts receivables balances at the end of 2007. CompX's average DSO increased from 41 days at December 31, 2006 to 44 days at December 31, 2007 due to timing of collection on the higher accounts receivable balance at the end of 2007.
- Kronos' average number of days in inventory ("DII") decreased from 68 days at December 31, 2006 to 59 days at December 31, 2007 due to the effects of higher TiO₂ sales volumes and lower TiO₂ production volumes. CompX's average DII increased from 57 days at December 31, 2006 to 66 days at December 31, 2007 due primarily to higher cost of commodity raw materials during 2007 and higher inventory balances associated with its facility consolidation in 2007.

We do not have complete access to the cash flows of our majority-owned subsidiaries, due in part to limitations contained in certain credit agreements of our subsidiaries and because we do not own 100% of these subsidiaries. A detail of our consolidated cash flows from operating activities is presented in the table below. Intercompany dividends have been eliminated.

	<u>Years ended December 31,</u>		
	<u>2006</u>	<u>2007</u>	<u>2008</u>
	(In millions)		
<i>Cash provided by (used in) operating activities:</i>			
Kronos	\$ 71.8	\$ 89.9	\$ 2.7
NL Parent	6.9	(11.2)	(11.5)
CompX	27.4	11.9	15.7
Waste Control Specialists	(3.9)	(11.2)	(9.9)
Tremont	(1.5)	(3.1)	(.7)
Valhi exclusive of subsidiaries	96.6	59.9	54.6
Other	(1.1)	(.7)	(1.6)
Eliminations	<u>(109.9)</u>	<u>(72.0)</u>	<u>(73.8)</u>
Total	<u>\$ 86.3</u>	<u>\$ 63.5</u>	<u>\$ (24.5)</u>

Investing Activities -

We disclose capital expenditures by our business segments in Note 2 to our Consolidated Financial Statements.

We had the following securities in market transactions during 2008:

- CompX purchased common stock through their stock repurchase program for \$1.0 million;
- NL purchased \$.8 million of Kronos common stock;
- we purchased other marketable securities of \$6.1 million; and
- we sold other marketable securities for proceeds of \$7.9 million.

In addition, we received \$39.6 million from the initial closing contained in a settlement agreement related to condemnation proceedings on certain real property we owned in New Jersey (see Note 15 to the Consolidated Financial Statements). We also received a \$15 million promissory note related to the settlement of condemnation proceedings.

We purchased the following securities in market transactions during 2007:

- other marketable securities of \$23.3 million;
- CompX common stock through their stock repurchase program for \$3.3 million; and
- TIMET common stock for \$.7 million.

In addition, during 2007 we sold other marketable securities for \$28.5 million.

We purchased the following securities in market transactions during 2006:

- Kronos common stock for \$25.4 million;
- TIMET common stock for \$18.7 million;
- CompX common stock for \$2.3 million; and
- other marketable securities for \$43.4 million.

In addition, during 2006 we:

- sold other marketable securities for \$42.9 million;
- sold certain land holdings in Nevada for \$37.9 million; and
- acquired a high performance marine components products company for \$9.8 million; and

Financing Activities -

During 2008, we:

- made net payments of \$1.7 million on Kronos' U.S. credit facility;
- made net borrowings of \$44.4 million on Kronos' European credit facility;
- repaid \$7.0 million on CompX's promissory note to TIMET; and
- borrowed a net \$7.3 million under our bank credit facility.

In October 2007, CompX's repurchased or cancelled a net 2.7 million such shares of its Class A common stock held by TIMET. CompX purchased for aggregate consideration of \$52.6 million, which it paid in the form of a promissory note. The promissory note bears interest at LIBOR plus 1% and provides for quarterly principal repayments of \$250,000 commencing in September 2008, with the balance due at maturity in September 2014. CompX may make prepayments on the promissory note at any time, in any amount, without penalty. The promissory note is subordinated to CompX's U.S. revolving bank credit agreement. In addition, during 2007, we:

- repaid \$2.6 million under CompX's promissory note payable to TIMET; and
- borrowed a net of \$9 million under Kronos' U.S. bank credit facility.

In April 2006, we issued euro 400 million aggregate principal amount of our 6.5% Senior Secured Notes due 2013 (\$498.5 million when issued), and used the proceeds to redeem our euro 375 million aggregate principal amount of 8.875% Senior Secured Notes in May 2006 (\$470.5 million when redeemed). In addition, during 2006 we:

- borrowed and repaid \$4.4 million under Kronos' Canadian revolving credit facility;
- repaid a net \$5.1 million under Kronos' U.S. bank credit facility; and
- repaid \$1.5 million of certain of CompX's indebtedness.

We paid aggregate cash dividends on our common stock of \$48.0 million in 2006, \$45.6 million in 2007 and \$45.5 million in 2008 (\$.10 per share per quarter). Distributions to minority interest in 2006, 2007 and 2008 are primarily comprised of Kronos cash dividends paid to shareholders other than us or NL, NL dividends paid to shareholders other than us and CompX dividends paid to shareholders other than NL.

We purchased approximately 1.9 million and .6 million shares of our common stock in 2006 and 2007, respectively, in market and other transactions for \$43.8 million and \$11.1 million, respectively. See Note 14 to our Consolidated Financial Statements. We funded these purchases with our available cash on hand. In 2008 NL purchased 79,000 shares of our common stock for \$1.0 million. These shares are included in our treasury stock balance. Other cash flows from financing activities in 2006, 2007 and 2008 relate principally to shares of common stock issued by us and our subsidiaries upon the exercise of stock options.

Outstanding Debt Obligations

At December 31, 2008, our consolidated third-party indebtedness was comprised of:

- KII's euro 400 million aggregate principal amount of its 6.5% Senior Secured Notes (\$560.0 million at December 31, 2008) due in 2013;
- our \$250 million loan from Snake River Sugar Company due in 2027;
- CompX's promissory note payable to TIMET (\$43.0 million outstanding at December 31, 2008) which has quarterly principal repayments of \$250,000 and is due in 2014;
- Kronos' U.S. revolving credit facility (\$13.7 million outstanding) due in 2011;
- KII's European revolving credit facility (\$42.2 million outstanding) due in 2011;
- Valhi's revolving credit facility (\$7.3 million outstanding) due in 2010; and
- approximately \$4.2 million of other indebtedness.

We and all of our subsidiaries are in compliance with all of our debt covenants at December 31, 2008. See Note 9 to our Consolidated Financial Statements. At December 31, 2008, \$9.4 million of our indebtedness is due within the next twelve months and therefore we do not currently expect we will be required to use a significant amount of our available liquidity to repay indebtedness during the next twelve months. In May 2008 we amended Kronos' European credit facility to extend the maturity date by three years to May 2011. In September 2008 we amended Kronos' U.S. revolving bank credit facility to extend the maturity date by three years to September 2011, and we increased the size of this facility from \$50.0 million to \$70.0 million. In October 2008 we amended Valhi's revolving bank facility to extend the maturity date by one year to October 2009, and we reduced the size of this facility from \$100.0 million to \$85.0 million. Kronos' Canadian revolving credit facility had a maturity date of January 15, 2009. Prior to maturity we temporarily extended our existing borrowing terms under our Canadian revolving credit facility on a month-to-month basis and we are currently in the process of renegotiating our facility, expecting a new agreement in place in the first quarter of 2009. In January 2009, CompX amended its credit facility to extend the maturity date to January 15, 2012 and to reduce the size of the facility from \$50.0 million to \$37.5 million.

Certain of our credit facilities require us to maintain specified financial ratios and satisfy certain financial covenants contained in the applicable credit agreement. While we were in compliance with all of our debt covenants at December 31, 2008, we currently believe it is probable that one of our required financial ratios associated with Kronos' European credit facility (the ratio of net secured debt to earnings before income taxes, interest and depreciation, as defined in the agreement) will not be maintained at some point during 2009, most likely commencing at March 31, 2009. In 2009, we have begun to reduce our production levels in response to the current economic environment, which we anticipate will favorably impact our liquidity and cash flows by reducing our inventory levels. However, the reduced capacity utilization levels will negatively impact on our Chemical Segment's 2009 operating income due to the resulting unabsorbed fixed production costs that will be charged to expense as incurred. As a result, we may not be able to maintain the required financial ratio throughout 2009.

We have begun discussions with the lenders to amend the terms of the existing European credit facility to eliminate the requirement to maintain this financial ratio until at least March 31, 2010. While we believe it is possible we can obtain such an amendment to eliminate this financial ratio through at least March 31, 2010, there is no assurance that such amendment will be obtained, or if obtained that the requirement to maintain the financial ratio will be eliminated (or waived, in the event the lenders would only agree to a waiver and not an amendment to eliminate the covenant itself) through at least March 31, 2010. Any such amendment or waiver which we might obtain could increase our future borrowing costs, either from a requirement that we pay a higher rate of interest on outstanding borrowings or pay a fee to the lenders as part of agreeing to such amendment or waiver.

In the event we would not be successful in obtaining the amendment or waiver of the existing European credit facility to eliminate the requirement to maintain the financial ratio, we would seek to refinance such facility with a new group of lenders with terms that did not include such financial covenant or, if required, we will use our existing liquidity resources (which could include funds provided by our affiliates). While there is no assurance that we would be able to refinance the existing European credit facility with a new group of lenders, we believe these other sources of liquidity available to us would allow us to refinance the existing European credit facility. If required, we believe by undertaking one or more of these steps we will be successful in maintaining sufficient liquidity to meet our future obligations including operations, capital expenditures and debt service for the next 12 months.

Future Cash Requirements

Liquidity -

Our primary source of liquidity on an ongoing basis is our cash flows from operating activities and borrowings under various lines of credit and notes. We generally use these amounts to (i) fund capital expenditures, (ii) repay short-term indebtedness incurred primarily for working capital purposes and (iii) provide for the payment of dividends (including dividends paid to us by our subsidiaries) or treasury stock purchases. From time-to-time we will incur indebtedness, generally to (i) fund short-term working capital needs, (ii) refinance existing indebtedness, (iii) make investments in marketable and other securities (including the acquisition of securities issued by our subsidiaries and affiliates) or (iv) fund major capital expenditures or the acquisition of other assets outside the ordinary course of business. Occasionally we sell assets outside the ordinary course of business, and we generally use the proceeds to (i) repay existing indebtedness (including indebtedness which may have been collateralized by the assets sold), (ii) make investments in marketable and other securities, (iii) fund major capital expenditures or the acquisition of other assets outside the ordinary course of business or (iv) pay dividends.

We routinely compare our liquidity requirements and alternative uses of capital against the estimated future cash flows we expect to receive from our subsidiaries, and the estimated sales value of those units. As a result of this process, we have in the past and may in the future seek to raise additional capital, refinance or restructure indebtedness, repurchase indebtedness in the market or otherwise, modify our dividend policies, consider the sale of our interests in our subsidiaries, affiliates, business units, marketable securities or other assets, or take a combination of these and other steps, to increase liquidity, reduce indebtedness and fund future activities. Such activities have in the past and may in the future involve related companies. From time to time we and our subsidiaries may enter into intercompany loans as a cash management tool. Such notes are structured as revolving demand notes and pay and receive interest on terms we believe are more favorable than current debt and investment market rates. The companies that receive these notes have sufficient borrowing capacity to repay the notes at anytime upon demand. All of these notes and related interest expense and income are eliminated in the Consolidated Financial Statements.

We periodically evaluate acquisitions of interests in or combinations with companies (including our affiliates) that may or may not be engaged in businesses related to our current businesses. We intend to consider such acquisition activities in the future and, in connection with this activity, may consider issuing additional equity securities and increasing indebtedness. From time to time, we also evaluate the restructuring of ownership interests among our respective subsidiaries and related companies.

Based upon our expectations of our operating performance, and the anticipated demands on our cash resources, we expect to have sufficient liquidity to meet our short-term obligations (defined as the twelve-month period ending December 31, 2009). In this regard, see the discussion above in "Outstanding debt obligations and borrowing availability". If actual developments differ from our expectations, our liquidity could be adversely affected.

At December 31, 2008, we had credit available under existing facilities of approximately \$230 million, which was comprised of:

- \$112 million under Kronos' various U.S. and non-U.S. credit facilities⁽¹⁾;
- \$68 million under Valhi's revolving bank credit facility; and
- \$50 million under CompX's revolving credit facility.

(1) \$70 million of Kronos' borrowing availability is related to the European credit facility and is subject to being in compliance with financial covenants or obtaining a waiver or amendment to the credit facility, as more fully described in **Outstanding Debt Obligations**.

At December 31, 2008, we had an aggregate of \$80.7 million of restricted and unrestricted cash, cash equivalents and marketable securities. A detail by entity is presented in the table below.

	<u>Amount</u> (In millions)
Valhi exclusive of its subsidiaries	\$ 9.3
Kronos	18.6
NL Parent	27.8
CompX	14.4
Tremont	8.1
Waste Control Specialists	<u>2.5</u>
Total cash, cash equivalents and marketable securities	<u>\$80.7</u>

Capital Expenditures -

We currently expect our aggregate capital expenditures for 2009 will be approximately \$103 million as follows:

- \$29 million in our Chemicals Segment;
- \$4 million in our Component Products Segment; and
- \$70 million in our Waste Management Segment.

The WCS amount includes approximately \$10 million in capitalized permit costs and major infrastructure improvements related to a new disposal contract signed in late 2007. Under the terms of the contract, we expect to be reimbursed for a majority of these infrastructure improvements that we will recognize as revenue over the life of the contract. Capital spending for 2009 is expected to be funded through cash generated from operations and credit facilities. Our Waste Management Segment received a byproduct disposal license in 2008 and pending some administrative matters expects to receive its LLRW license in the second quarter of 2009. With the receipt of these licenses, WCS has begun construction of a byproduct disposal facility which is expected to be completed in the second quarter of 2009 and a LLRW facility which is expected to begin construction in the second quarter of 2009. Approximately \$43 million of WCS' planned capital spending relate to these new facilities. WCS is currently seeking financing to fund construction of these facilities, and a delay in obtaining such financing could result in a delay in the commencement of constructing the LLRW facility. In March 2009, the Andrews County Commissioners' Court ordered a May 9, 2009 election on the potential bond sale of up to \$75 million to provide financing for the construction.

With the exception of our Waste Management Segment, we have lowered our planned capital expenditures in 2009 in response to the current economic conditions. We are limiting 2009 investments to those expenditures required to meet our lower expected customer demand and those required to properly maintain our facilities.

Repurchases of our Common Stock -

We have in the past, and may in the future, make repurchases of our common stock in market or privately-negotiated transactions. At December 31, 2008 we had approximately 4.3 million shares available for repurchase of our common stock under the authorizations described in Note 14 to our Consolidated Financial Statements.

Dividends -

Because our operations are conducted primarily through subsidiaries and affiliates, our long-term ability to meet parent company level corporate obligations is largely dependent on the receipt of dividends or other distributions from our subsidiaries and affiliates. In February 2009, Kronos' board voted to suspend its quarterly dividend after considering the challenges and opportunities that exist in the TiO₂ pigment industry and we do not currently expect to receive a dividend from Kronos in 2009. NL's current quarterly cash dividend is \$.125 per share, although in the past NL has paid a dividend in the form of Kronos common stock. If NL pays its regular quarterly dividends in cash, based on the 40.4 million shares we held of NL common stock at December 31, 2008, we would receive aggregate annual dividends from NL of \$20.2 million. We do not expect to receive any distributions from WCS during 2009.

Our subsidiaries have various credit agreements which contain customary limitations on the payment of dividends, typically a percentage of net income or cash flow; however, these restrictions in the past have not significantly impacted their ability to pay dividends.

Investment in our Subsidiaries and Affiliates and Other Acquisitions -

We have in the past, and may in the future, purchase the securities of our subsidiaries and affiliates or third parties in market or privately-negotiated transactions. We base our purchase decisions on a variety of factors, including an analysis of the optimal use of our capital, taking into account the market value of the securities and the relative value of expected returns on alternative investments. In connection with these activities, we may consider issuing additional equity securities or increasing our indebtedness. We may also evaluate the restructuring of ownership interests of our businesses among our subsidiaries and related companies.

We generally do not guarantee any indebtedness or other obligations of our subsidiaries or affiliates. Our subsidiaries are not required to pay us dividends. If one or more of our subsidiaries were unable to maintain its current level of dividends, either due to restrictions contained in a credit agreement or to satisfy its liabilities or otherwise, our ability to service our liabilities or to pay dividends on our common stock might be adversely impacted. If this were to occur, we might consider reducing or eliminating our dividends or selling interests in subsidiaries or other assets. If we were required to liquidate assets to generate funds to satisfy our liabilities, we might be required to sell at what we believe would be less than the actual value of such assets.

WCS' primary source of liquidity currently consists of intercompany borrowings from one of our wholly-owned subsidiaries under the terms of a revolving credit facility. We eliminate these intercompany borrowings in our Consolidated Financial Statements. During 2008, WCS borrowed a net \$31.3 million from our subsidiary. WCS used these net borrowings primarily to fund its operating loss and capital expenditures. We contributed \$31.9 million of these net borrowings to WCS' equity in November 2008. We expect that WCS will likely borrow additional amounts from us during 2008 under the terms of the revolving credit facility, and we may similarly contribute such borrowings to WCS' capital. At December 31, 2008, WCS can borrow an additional \$29.8 million under this facility, which matures in March 2010.

Investment in The Amalgamated Sugar Company LLC -

The terms of The Amalgamated Sugar Company LLC Company Agreement provide for an annual "base level" of cash dividend distributions (sometimes referred to as distributable cash) by the LLC of \$26.7 million, from which we are entitled to a 95% preferential share. Distributions from the LLC are dependent, in part, upon the operations of the LLC. We record dividend distributions from the LLC as income when they are declared by the LLC, which is generally the same month in which we receive the distributions, although distributions may in certain cases be paid on the first business day of the following month. To the extent the LLC's distributable cash is below this base level in any given year, we are entitled to an additional 95% preferential share of any future annual LLC distributable cash in excess of the base level until such shortfall is recovered. Based on the LLC's current projections for 2009, we expect distributions received from the LLC in 2009 will exceed our debt service requirements under our \$250 million loans from Snake River Sugar Company by approximately \$1.8 million.

We may, at our option, require the LLC to redeem our interest in the LLC beginning in 2012, and the LLC has the right to redeem our interest in the LLC beginning in 2027. The redemption price is generally \$250 million plus the amount of certain undistributed income allocable to us, if any. In the event we require the LLC to redeem our interest in the LLC, Snake River has the right to accelerate the maturity of and call our \$250 million loans from Snake River. Redemption of our interest in the LLC would result in us reporting income related to the disposition of our LLC interest for income tax purposes, although we would not be expected to report a gain in earnings for financial reporting purposes at the time our LLC interest is redeemed. However, because of Snake River's ability to call our \$250 million loans from Snake River upon redemption of our interest in the LLC, the net cash proceeds (after repayment of the debt) generated by the redemption of our interest in the LLC could be less than the income taxes that we would be required to pay as a result of the disposition.

Off-balance Sheet Financing

We do not have any off-balance sheet financing agreements other than the operating leases discussed in Note 17 to our Consolidated Financial Statements.

Commitments and Contingencies

We are subject to certain commitments and contingencies, as more fully described in the Notes to our Consolidated Financial Statements and in this Management's Discussion and Analysis of Financial Condition and Results of Operations, including:

- certain income tax examinations which are underway in various U.S. and non-U.S. jurisdictions;
- certain environmental remediation matters involving NL, Tremont and Valhi;
- certain litigation related to NL's former involvement in the manufacture of lead pigment and lead-based paint; and
- certain other litigation to which we are a party.

In addition to those legal proceedings described in Note 17 to our Consolidated Financial Statements, various legislation and administrative regulations have, from time to time, been proposed that seek to (i) impose various obligations on present and former manufacturers of lead pigment and lead-based paint (including NL) with respect to asserted health concerns associated with the use of such products and (ii) effectively overturn court decisions in which we and other pigment manufacturers have been successful. Examples of such proposed legislation include bills which would permit civil liability for damages on the basis of market share, rather than requiring plaintiffs to prove that the defendant's product caused the alleged damage, and bills which would revive actions barred by the statute of limitations. While no legislation or regulations have been enacted to date that are expected to have a material adverse effect on our consolidated financial position, results of operations or liquidity, enactment of such legislation could have such an effect.

As more fully described in the Notes to our Consolidated Financial Statements, we are a party to various debt, lease and other agreements which contractually and unconditionally commit us to pay certain amounts in the future. See Notes 9 and 17 to our Consolidated Financial Statements. Our obligations related to the long-term supply contract for the purchase of TiO₂ feedstock is more fully described in Note 17 to our Consolidated Financial Statements and above in "Business - Chemicals - Kronos Worldwide, Inc. - manufacturing process, properties and raw materials." The following table summarizes our contractual commitments as of December 31, 2008 by the type and date of payment.

<u>Contractual commitment</u>	<u>Payment due date</u>				<u>Total</u>
	<u>2009</u>	<u>2010/2011</u>	<u>2012/2013</u>	<u>2014 and after</u>	
	<u>(In millions)</u>				
Indebtedness ⁽¹⁾ :					
Principal	\$ 9.4	\$ 60.1	\$562.9	\$ 288.0	\$ 920.4
Interest	25.8	51.1	50.9	306.9	434.7
Operating leases ⁽²⁾	5.9	7.2	3.9	18.9	35.9
Kronos' long-term supply contracts for the purchase of TiO ₂ feedstock ⁽³⁾	229.0	276.0	-	-	505.0
Kronos' long-term service and other supply contracts ⁽⁴⁾	48.4	51.5	11.3	1.8	113.0
CompX raw material and other purchase commitments ⁽⁵⁾	16.5	-	-	-	16.5
Fixed asset acquisitions ⁽²⁾	43.7	-	-	-	43.7
Income taxes ⁽⁶⁾	<u>6.2</u>	<u>-</u>	<u>-</u>	<u>-</u>	<u>6.2</u>
Total	<u>\$384.9</u>	<u>\$445.9</u>	<u>\$629.0</u>	<u>\$ 615.6</u>	<u>\$2,075.4</u>

- (1) The amount shown for indebtedness involving revolving credit facilities is based upon the actual amount outstanding at December 31, 2008, and the amount shown for interest for any outstanding variable-rate indebtedness is based upon the December 31, 2008 interest rate and assumes that such variable-rate indebtedness remains outstanding until the maturity of the facility. A significant portion of the amount shown for indebtedness relates to KII's 6.5% Senior Secured Notes (\$560.0 million at December 31, 2008), which is denominated in the euro. See Item 7A - "Quantitative and Qualitative Disclosures About Market Risk" and Note 9 to our Consolidated Financial Statements.
- (2) The timing and amount shown for our commitments operating leases and fixed asset acquisitions are based upon the contractual payment amount and the contractual payment date for such commitments.
- (3) Our contracts for the purchase of TiO₂ feedstock contain fixed quantities we are required to purchase, although certain of these contracts allow for an upward or downward adjustment in the quantity purchased, generally no more than 10%, based on our feedstock requirements. The pricing under these agreements is generally based on a fixed price with price escalation clauses primarily based on consumer price indices, as defined in the respective contracts. The timing and amount shown for our commitments related to the long-term supply contracts for TiO₂ feedstock are based upon our current estimate of the quantity of material that will be purchased in each time period shown, and the payment that would be due based upon such estimated purchased quantity and an estimate of the effect of the price escalation clause. The actual amount of material purchased, and the actual amount that would be payable by us, may vary from such estimated amounts.
- (4) The amounts shown for the long-term service and other supply contracts primarily pertain to agreements Kronos entered into with various providers of products or services which help to run its plant facilities (electricity, natural gas, etc.), utilizing December 31, 2008 exchange rates.

- (5) CompX's purchase obligations consist of all open purchase orders and contractual obligations (primarily commitments to purchase raw materials) and is based on the contractual payment amount and the contractual payment date for those commitments.
- (6) The amount shown for income taxes is the amount of our consolidated current income taxes payable including the net amount payable to Contran under our tax sharing agreement at December 31, 2008, which is assumed to be paid during 2009.

The table above does not include:

- (1) Our obligation under the Louisiana Pigment Company, L.P. joint venture, as the timing and amount of such purchases are unknown and dependent on, among other things, the amount of TiO₂ produced by the joint venture in the future, and the joint venture's future cost of producing such TiO₂. However, the table of contractual commitments does include amounts related to our share of the joint venture's ore requirements necessary for it to produce TiO₂ for us. See Notes 7 and 17 to our Consolidated Financial Statements and "*Business - Chemicals - Kronos Worldwide, Inc.*"
- (2) We are party to an agreement that could require us to pay certain amounts to a third party based upon specified percentages of our qualifying Waste Management revenues. We have not included any amounts for this conditional commitment in the above table because we currently believe it is not probable that we will be required to pay any amounts pursuant to this agreement.
- (3) Amounts we might pay to fund our defined benefit pension plans and OPEB plans, as the timing and amount of any such future fundings are unknown and dependent on, among other things, the future performance of defined benefit pension plan assets, interest rate assumptions and actual future retiree medical costs. Our defined benefit pension plans and OPEB plans are discussed in greater detail in Note 11 to our Consolidated Financial Statements. We currently expect we will be required to contribute an aggregate of \$21.8 million to our defined benefit pension and OPEB plans during 2009.
- (4) Any amounts that we might pay to settle any of our uncertain tax positions, as the timing and amount of any such future settlements are unknown and dependent on, among other things, the timing of tax audits. See Notes 12 and 18 to our Consolidated Financial Statements.

Recent Accounting Pronouncements

See Note 18 to the Consolidated Financial Statements

ITEM 7A. QUANTITATIVE AND QUALITATIVE DISCLOSURES ABOUT MARKET RISK

General. We are exposed to market risk from changes in interest rates, currency exchange rates, raw materials and equity security prices.

Interest Rates. We are exposed to market risk from changes in interest rates, primarily related to our indebtedness.

At December 31, 2008 our aggregate indebtedness was split between 88% of fixed-rate instruments and 12% of variable-rate borrowings (in 2007 the percentages were 93% of fixed-rate instruments and 7% of variable rate borrowings). The large percentage of fixed-rate debt instruments minimizes earnings volatility that would result from changes in interest rates. The following table presents principal amounts and weighted average interest rates for our aggregate outstanding indebtedness at December 31, 2008. Information shown below for foreign currency denominated indebtedness is presented in its U.S. dollar equivalent at December 31, 2008 using an exchange rate of 1.4061 U.S. dollars per euro.

The table below shows the fair value of our financial liabilities at December 31, 2008.

<u>Indebtedness*</u>	<u>Amount</u>		<u>Interest rate</u>	<u>Maturity date</u>
	<u>Carrying value</u>	<u>Fair value</u>		
	(In millions)			
Fixed-rate indebtedness:				
Euro-denominated KII				
6.5% Senior Secured Notes	\$560.0	\$129.4	6.5%	2013
Valhi loans from Snake River	250.0	250.0	9.4	2027
Other	<u>4.2</u>	<u>4.2</u>	Various	Various
Fixed-rate	<u>814.2</u>	<u>383.6</u>	7.4%	
Variable-rate indebtedness -				
CompX promissory note to TIMET	43.0	43.0	5.0%	2014
Kronos Euro denominated revolver	42.2	42.2	4.5	2011
Kronos U.S. revolver	13.7	13.7	3.3	2011
Valhi revolver	<u>7.3</u>	<u>7.3</u>	3.3	2009
Variable-rate	<u>106.2</u>	<u>106.2</u>	4.5%	
Total	<u>\$920.4</u>	<u>\$489.8</u>	7.1%	

* Denominated in U.S. dollars, except as otherwise indicated. Excludes capital lease obligations.

At December 31, 2007, our fixed rate indebtedness aggregated \$835.9 million (the fair value was \$758.1 million) with a weighted-average interest rate of 7.4%; our variable rate indebtedness aggregated \$65.4 million, which approximated fair value, with a weighted average interest rate of 6.4%. Approximately 70% of such fixed rate indebtedness was denominated in the euro, with the remainder denominated in the U.S. dollar. All of the outstanding variable rate borrowings were denominated in the U.S. dollar.

Currency Exchange Rates. We are exposed to market risk arising from changes in foreign currency exchange rates as a result of manufacturing and selling our products worldwide. Our earnings are primarily affected by fluctuations in the value of the U.S. dollar relative to the euro, the Canadian dollar, the Norwegian krone and the British pound sterling.

As described above, at December 31, 2008, we had the equivalent of \$602.2 million of outstanding euro-denominated indebtedness (in 2007 the equivalent of \$585.5 million of euro-denominated indebtedness). The potential increase in the U.S. dollar equivalent of the principal amount outstanding resulting from a hypothetical 10% adverse change in exchange rates at such date would be approximately \$60.5 million at December 31, 2008 (in 2007 the amount was \$58.9 million).

We periodically use currency forward contracts to manage a portion of foreign currency exchange rate market risk associated with trade receivables, or similar exchange rate risk associated with future sales, denominated in a currency other than the holder's functional currency. These contracts generally relate to our Chemicals and Component Products operations. We have not entered into these contracts for trading or speculative purposes in the past, nor do we currently anticipate entering into such contracts for trading or speculative purposes in the future. Some of the currency forward contracts we enter into meet the criteria for hedge accounting under GAAP and are designated as cash flow hedges. For these currency forward contracts, gains

and losses representing the effective portion of our hedges are deferred as a component of accumulated other comprehensive income, and are subsequently recognized in earnings at the time the hedged item affects earnings. For the currency forward contracts we enter into which do not meet the criteria for hedge accounting, we mark-to-market the estimated fair value of such contracts at each balance sheet date, with any resulting gain or loss recognized in income currently as part of net currency transactions. We had no forward contracts outstanding at December 31, 2007. At December 31, 2008 we held the following series of short-term forward exchange contracts.

- Our Component Products Segment entered into a series of short-term forward exchange contracts maturing through June 2009 to exchange an aggregate of \$7.5 million for an equivalent value of Canadian dollars at an exchange rates of Cdn. \$1.25 to \$1.26 per U.S. dollar. At December 31, 2008, the actual exchange rate was Cdn. \$1.22 per U.S. dollar.;
- Our Chemicals Segment entered into an aggregate of \$30.0 million for an equivalent value of Canadian dollars at exchange rates ranging from Cdn. \$1.25 to Cdn. \$1.26 per U.S. dollar. These contracts with U.S. Bank mature from January 2009 through December 2009 at a rate of \$2.5 million per month. At December 31, 2008, the actual exchange rate was Cdn. \$1.22 per U.S. dollar.
- Our Chemicals Segment entered an aggregate \$57 million for an equivalent value of Norwegian kroner at exchange rates ranging from kroner 6.91 to kroner 7.18. These contracts with DnB Nor Bank ASA mature from January 2009 through December 2009 at a rate of .5 million to \$2.5 million per month. At December 31, 2008, the actual exchange rate was kroner 7.0 per U.S. dollar.
- Our Chemicals Segment entered an aggregate euro 16.4 million for an equivalent value of Norwegian kroner at exchange rates ranging from kroner 8.64 to kroner 9.23. These contracts with DnB Nor Bank ASA mature from January 2009 through December 2009 at a rate of euro .5 million to euro .7 million per month. At December 31, 2008, the actual exchange rate was kroner 9.7 per euro.

Other than the contracts discussed above, we were not a party to any forward or derivative option contract related to foreign exchange rates, interest rates or equity security prices at December 31, 2008. To the extent we held such contracts during 2007 and 2008, we did not use hedge accounting for any of our contracts. See Notes 1 and 19 to our Consolidated Financial Statements for a discussion of the assumptions we used to estimate the fair value of the financial instruments to which we are a party at December 31, 2007 and 2008.

Raw Materials. Our Chemicals Segment generally enters into long-term supply agreements for critical raw materials, including natural rutile ore and slag. Many of these raw material contracts contain fixed quantities we are required to purchase, although these contracts allow for an upward or downward adjustment in the quantity purchased. Raw material pricing under these agreements is generally negotiated annually. Our Component Products Segment will occasionally enter into raw material arrangements to mitigate the short-term impact of future increases in raw material costs. Otherwise, we generally do not have long-term supply agreements for our raw material requirements because either we believe the risk of unavailability of those raw materials is low and we believe the price to be stable or because long-term supply agreements for those materials are generally not available. We do not engage in commodity hedging programs.

Marketable Equity and Debt Security Prices. We are exposed to market risk due to changes in prices of the marketable securities that we own. The fair value of such debt and equity securities (determined using Level 1, Level 2 and Level 3 inputs) at December 31, 2007 and 2008 was \$327.0 million and

\$284.3 million, respectively. The potential change in the aggregate fair value of these investments, assuming a 10% change in prices, would be \$32.7 million at December 31, 2007 and \$28.4 million at December 31, 2008.

Other. We believe there may be a certain amount of incompleteness in the sensitivity analyses presented above. For example, the hypothetical effect of changes in interest rates discussed above ignores the potential effect on other variables that affect our results of operations and cash flows, such as demand for our products, sales volumes and selling prices and operating expenses. Contrary to the above assumptions, changes in interest rates rarely result in simultaneous comparable shifts along the yield curve. Also, our investment in The Amalgamated Sugar Company LLC represents a significant portion of our total portfolio of marketable securities. That investment serves as collateral for our loans from Snake River Sugar Company, and a decrease in the fair value of that investment would likely be mitigated by a decrease in the fair value of the related indebtedness. Accordingly, the amounts we present above are not necessarily an accurate reflection of the potential losses we would incur assuming the hypothetical changes in market prices were actually to occur.

The above discussion and estimated sensitivity analysis amounts include forward-looking statements of market risk which assume hypothetical changes in market prices. Actual future market conditions will likely differ materially from such assumptions. Accordingly, such forward-looking statements should not be considered to be projections by us of future events, gains or losses.

ITEM 8. FINANCIAL STATEMENTS AND SUPPLEMENTARY DATA

The information called for by this Item is contained in a separate section of this Annual Report. See "Index of Financial Statements and Schedule" (page F-1).

ITEM 9. CHANGES IN AND DISAGREEMENTS WITH ACCOUNTANTS ON ACCOUNTING AND FINANCIAL DISCLOSURE

None.

ITEM 9A. CONTROLS AND PROCEDURES

Evaluation of Disclosure Controls and Procedures -

We maintain a system of disclosure controls and procedures. The term "disclosure controls and procedures," as defined by Exchange Act Rule 13a-15(e), means controls and other procedures that are designed to ensure that information required to be disclosed in the reports we file or submit to the SEC under the Securities Exchange Act of 1934, as amended (the "Act"), is recorded, processed, summarized and reported, within the time periods specified in the SEC's rules and forms. Disclosure controls and procedures include, without limitation, controls and procedures designed to ensure that information we are required to disclose in the reports we file or submit to the SEC under the Act is accumulated and communicated to our management, including our principal executive officer and our principal financial officer, or persons performing similar functions, as appropriate to allow timely decisions to be made regarding required disclosure. Each of Steven L. Watson, our President and Chief Executive Officer, and Bobby D. O'Brien, our Vice President and Chief Financial Officer, have evaluated the design and effectiveness of our disclosure controls and procedures as of December 31, 2008. Based upon their evaluation, these executive officers have concluded that our disclosure controls and procedures were effective as of December 31, 2008.

Internal Control Over Financial Reporting -

We also maintain internal control over financial reporting. The term "internal control over financial reporting," as defined by Exchange Act Rule 13a-15(f), means a process designed by, or under the supervision of, our principal executive and principal financial officers, or persons performing similar functions, and effected by our board of directors, management and other personnel, to provide reasonable assurance regarding the reliability of financial reporting and the preparation of financial statements for external purposes in accordance with GAAP, and includes those policies and procedures that:

- pertain to the maintenance of records that in reasonable detail accurately and fairly reflect our transactions and dispositions of our assets,
- provide reasonable assurance that transactions are recorded as necessary to permit preparation of financial statements in accordance with GAAP, and that our receipts and expenditures are made only in accordance with authorizations of our management and directors, and
- provide reasonable assurance regarding prevention or timely detection of unauthorized acquisition, use or disposition of our assets that could have a material effect on our Condensed Consolidated Financial Statements.

Section 404 of the Sarbanes-Oxley Act of 2002 requires us to report on internal control over financial reporting in this Annual Report on Form 10-K for the year ended December 31, 2008. Our independent registered public accounting firm is also required to audit our internal control over financial reporting as of December 31, 2008.

As permitted by the SEC, our assessment of internal control over financial reporting excludes (i) internal control over financial reporting of our equity method investees and (ii) internal control over the preparation of our financial statement schedules required by Article 12 of Regulation S-X. However, our assessment of internal control over financial reporting with respect to our equity method investees did include our controls over the recording of amounts related to our investment that are recorded in our Consolidated Financial Statements, including controls over the selection of accounting methods for our investments, the recognition of equity method earnings and losses and the determination, valuation and recording of our investment account balances.

Changes in Internal Control Over Financial Reporting -

There has been no change to our internal control over financial reporting during the quarter ended December 31, 2008 that has materially affected, or is reasonably likely to materially affect, our internal control over financial reporting.

Management's Report on Internal Control Over Financial Reporting -

Our management is responsible for establishing and maintaining adequate internal control over financial reporting, as such term is defined in Exchange Act Rules 13a-15(f) and 15d-15(f). Our evaluation of the effectiveness of our internal control over financial reporting is based upon the criteria established in *Internal Control - Integrated Framework* issued by the Committee of Sponsoring Organizations of the Treadway Commission (commonly referred to as the "COSO" framework). Based on our evaluation under that framework, we have concluded that our internal control over financial reporting was effective as of December 31, 2008.

PricewaterhouseCoopers LLP, the independent registered public accounting firm that has audited our Consolidated Financial Statements included in this Annual Report has audited the effectiveness of our internal control over financial reporting as of December 31, 2008, as stated in their report which is included in this Annual Report on Form 10-K.

Certifications -

Our chief executive officer is required to annually file a certification with the New York Stock Exchange ("NYSE"), certifying our compliance with the corporate governance listing standards of the NYSE. During 2008, our chief executive officer filed such annual certification with the NYSE, indicating we were in compliance with such listing standards without qualification. Our chief executive officer and chief financial officer are also required to, among other things, quarterly file certifications with the SEC regarding the quality of our public disclosures, as required by Section 302 of the Sarbanes-Oxley Act of 2002. We have filed the certifications for the quarter ended December 31, 2008 as exhibits 31.1 and 31.2 to this Annual Report on Form 10-K.

ITEM 9B. OTHER INFORMATION

Not applicable.

PART III

ITEM 10. DIRECTORS, EXECUTIVE OFFICERS AND CORPORATE GOVERNANCE

The information required by this Item is incorporated by reference to our definitive Proxy Statement we will file with the SEC pursuant to Regulation 14A within 120 days after the end of the fiscal year covered by this report (the "Valhi Proxy Statement").

ITEM 11. EXECUTIVE COMPENSATION

The information required by this Item is incorporated by reference to the Valhi Proxy Statement.

ITEM 12. SECURITY OWNERSHIP OF CERTAIN BENEFICIAL OWNERS AND MANAGEMENT AND RELATED STOCKHOLDER MATTERS

The information required by this Item is incorporated by reference to the Valhi Proxy Statement.

ITEM 13. CERTAIN RELATIONSHIPS AND RELATED TRANSACTIONS AND DIRECTORS INDEPENDENCE

The information required by this Item is incorporated by reference to the Valhi Proxy Statement. See also Note 17 to the Consolidated Financial Statements.

ITEM 14. PRINCIPAL ACCOUNTING FEES AND SERVICES

The information required by this Item is incorporated by reference to the Valhi Proxy Statement.

PART IV

ITEM 15. EXHIBITS AND FINANCIAL STATEMENT SCHEDULES

(a) and (c) Financial Statements and Schedules

The Registrant

Our Consolidated Financial Statements and schedule listed on the accompanying Index of Financial Statements and Schedule (see page F-1) are filed as part of this Annual Report.

50%-or-less owned persons

TIMET's condensed consolidated financial statements are filed as Exhibit 99.1 of this Annual Report pursuant to Rule 3-09 of Regulation S-X. TIMET's Management's Report on Internal Control Over Financial Reporting is not included as part of Exhibit 99.1. We are not required to provide any other consolidated financial statements pursuant to Rule 3-09 of Regulation S-X.

(b) Exhibits

Included as exhibits are the items listed in the Exhibit Index. We have retained a signed original of any of these exhibits that contain signatures, and we will provide such exhibit to the Commission or its staff upon request. We will furnish a copy of any of the exhibits listed below upon request and payment of \$4.00 per exhibit to cover our costs of furnishing the exhibits. Such requests should be directed to the attention of our Corporate Secretary at our corporate offices located at 5430 LBJ Freeway, Suite 1700, Dallas, Texas 75240.

Pursuant to Item 601(b)(4)(iii) of Regulation S-K, we will furnish to the Commission upon request any instrument defining the rights of holders of long-term debt issues and other agreements related to indebtedness which do not exceed 10% of our consolidated total assets as of December 31, 2008.

Item No.

Exhibit Index

- 3.1 Restated Articles of Incorporation of Valhi, Inc. - incorporated by reference to Exhibit 3.1 to our Current Report on Form 8-K/A (File No. 1-5467) dated March 26, 2007 and filed by us on March 29, 2007.
- 3.2 By-Laws of Valhi, Inc. as amended - incorporated by reference to Exhibit 3.1 of our Current Report on Form 8-K (File No. 1-5467) dated November 6, 2007.
- 4.1 Indenture dated April 11, 2006 between Kronos International, Inc. and The Bank of New York, as Trustee, governing Kronos International's 6.5% Senior Secured Notes due 2013 - incorporated by reference to Exhibit 4.1 to Kronos International, Inc.'s Current Report on Form 8-K (File No. 333-100047) filed with the SEC on April 11, 2006.
- 10.1 Intercorporate Services Agreement between Valhi, Inc. and Contran Corporation effective as of January 1, 2004 - incorporated by reference to Exhibit 10.1 to our Quarterly Report on Form 10-Q for the quarter ended March 31, 2004.
- 10.2 Intercorporate Services Agreement between Contran Corporation and NL effective as of January 1, 2004 - incorporated by reference to Exhibit 10.1 to NL's Quarterly Report on Form 10-Q (File No. 1-640) for the quarter ended March 31, 2004.
- 10.3 Intercorporate Services Agreement between Contran Corporation and CompX effective January 1, 2004 - incorporated by reference to Exhibit 10.2 to CompX's Annual Report on Form 10-K (File No. 1-13905) for the year ended December 31, 2003.
- 10.4 Intercorporate Services Agreement between Contran Corporation and Kronos Worldwide, Inc. effective January 1, 2004 - incorporated by reference to Exhibit No. 10.1 to Kronos' Quarterly Report on Form 10-Q (File No. 1-31763) for the quarter ended March 31, 2004.
- 10.5 Stock Purchase Agreement dated April 1, 2005 between Valhi, Inc. and Contran Corporation - incorporated by reference to Exhibit 99.1 to our Current Report on Form 8-K (File No. 1-5467) dated April 1, 2005.
- 10.6 Stock Purchase Agreement dated November 1, 2006 between Valhi, Inc. and Valhi Holding Company - incorporated by reference to Exhibit 10.1 - to our Current Report on Form 8-K (File No. 1-5467) dated November 1, 2006.
- 10.7 Stock Purchase Agreement dated as of March 26, 2007 between Valhi, Inc. and Contran Corporation - incorporated by reference to Exhibit 10.1 to our Current Report on Form 8-K (File No. 1-5467) dated March 26, 2007 and filed by us on March 27, 2007.
- 10.8 Consent Agreement dated as of March 29, 2007 between Valhi, Inc. and Contran Corporation - incorporated by reference to Exhibit 10.2 to our Current Report on Form 8-K/A (File No. 1-5467) dated March 26, 2007 and filed by us on March 29, 2007.

Item No.Exhibit Index

- 10.9 Stock Purchase Agreement dated as of October 16, 2007 between TIMET Finance Management Company and CompX International Inc. - incorporated by reference to Exhibit 10.1 of CompX's Current Report on Form 8-K (File No. 1-13905) dated October 22, 2007.
- 10.10 Agreement and Plan of Merger dated as of October 16, 2007 among CompX International Inc., CompX Group, Inc. and CompX KDL LLC - incorporated by reference to Exhibit 10.2 of CompX's Current Report on Form 8-K (File No. 1-13905) dated October 22, 2007.
- 10.11 Subordinated Term Loan Promissory Note dated October 26, 2007 executed by CompX International Inc. and payable to the order of TIMET Finance Management Company - incorporated by reference to Exhibit 10.4 of CompX's Quarterly Report on Form 10-Q (File No. 1-13905) for the quarter ended September 30, 2007.
- 10.12 Form of Subordination Agreement among TIMET Finance Management Company, CompX International Inc., CompX Security Products, Inc., CompX Precision Slides Inc., CompX Marine Inc., Custom Marine Inc., Livorsi Marine Inc., Wachovia Bank, National Association as administrative agent for itself, Compass Bank and Comerica Bank - incorporated by reference to Exhibit 10.4 of CompX's Current Report on Form 8-K dated October 22, 2007.
- 10.13* Valhi, Inc. 1997 Long-Term Incentive Plan - incorporated by reference to Exhibit 10.12 to Valhi, Inc.'s Annual Report on Form 10-K (File No. 1-5467) for the year ended December 31, 1996.
- 10.14* CompX International Inc. 1997 Long-Term Incentive Plan - incorporated by reference to Exhibit 10.2 to CompX's Registration Statement on Form S-1 (File No. 333-42643).
- 10.15* NL Industries, Inc. 1998 Long-Term Incentive Plan - incorporated by reference to Appendix A to NL's Proxy Statement on Schedule 14A (File No. 1-640) for the annual meeting of shareholders held on May 9, 1998.
- 10.16* Kronos Worldwide, Inc. 2003 Long-Term Incentive Plan - incorporated by reference to Exhibit 10.4 to Kronos' Registration Statement on Form 10 (File No. 001-31763).
- 10.17 Agreement Regarding Shared Insurance dated as of October 30, 2003 by and between CompX International Inc., Contran Corporation, Keystone Consolidated Industries, Inc., Kronos Worldwide, Inc., NL Industries, Inc., Titanium Metals Corporation and Valhi, Inc. - incorporated by reference to Exhibit 10.32 to Kronos' Annual Report on Form 10-K (File No. 1-31763) for the year ended December 31, 2003.
- 10.18 Formation Agreement of The Amalgamated Sugar Company LLC dated January 3, 1997 (to be effective December 31, 1996) between Snake River Sugar Company and The Amalgamated Sugar Company - incorporated by reference to Exhibit 10.19 to Valhi, Inc.'s Annual Report on Form 10-K (File No. 1-5467) for the year ended December 31, 1996.

Item No.Exhibit Index

- 10.19 Master Agreement Regarding Amendments to The Amalgamated Sugar Company Documents dated October 19, 2000 - incorporated by reference to Exhibit 10.1 to Valhi, Inc.'s Quarterly Report on Form 10-Q (File No. 1-5467) for the quarter ended September 30, 2000.
- 10.20 Prepayment and Termination Agreement dated October 14, 2005 among Valhi, Inc., Snake River Sugar Company and Wells Fargo Bank Northwest, N.A. - incorporated by reference to Exhibit No. 10.1 to Valhi, Inc.'s Amendment No. 1 to its Current Report on Form 8-K (File No. 1-5467) dated October 18, 2005.
- 10.21 Company Agreement of The Amalgamated Sugar Company LLC dated January 3, 1997 (to be effective December 31, 1996) - incorporated by reference to Exhibit 10.20 to Valhi, Inc.'s Annual Report on Form 10-K (File No. 1-5467) for the year ended December 31, 1996.
- 10.22 First Amendment to the Company Agreement of The Amalgamated Sugar Company LLC dated May 14, 1997 - incorporated by reference to Exhibit 10.1 to Valhi, Inc.'s Quarterly Report on Form 10-Q (File No. 1-5467) for the quarter ended June 30, 1997.
- 10.23 Second Amendment to the Company Agreement of The Amalgamated Sugar Company LLC dated November 30, 1998 - incorporated by reference to Exhibit 10.24 to Valhi, Inc.'s Annual Report on Form 10-K (File No. 1-5467) for the year ended December 31, 1998.
- 10.24 Third Amendment to the Company Agreement of The Amalgamated Sugar Company LLC dated October 19, 2000 - incorporated by reference to Exhibit 10.2 to Valhi, Inc.'s Quarterly Report on Form 10-Q (File No. 1-5467) for the quarter ended September 30, 2000.
- 10.25 Amended and Restated Company Agreement of The Amalgamated Sugar Company LLC dated October 14, 2005 among The Amalgamated Sugar Company LLC, Snake River Sugar Company and The Amalgamated Collateral Trust - incorporated by reference to Exhibit No. 10.7 to Valhi, Inc.'s Amendment No. 1 to its Current Report on Form 8-K (File No. 1-5467) dated October 18, 2005.
- 10.26 Subordinated Promissory Note in the principal amount of \$37.5 million between Valhi, Inc. and Snake River Sugar Company, and the related Pledge Agreement, both dated January 3, 1997 - incorporated by reference to Exhibit 10.21 to Valhi, Inc.'s Annual Report on Form 10-K (File No. 1-5467) for the year ended December 31, 1996.
- 10.27 Limited Recourse Promissory Note in the principal amount of \$212.5 million between Valhi, Inc. and Snake River Sugar Company, and the related Limited Recourse Pledge Agreement, both dated January 3, 1997 - incorporated by reference to Exhibit 10.22 to Valhi, Inc.'s Annual Report on Form 10-K (File No. 1-5467) for the year ended December 31, 1996.
- 10.28 Subordinated Loan Agreement between Snake River Sugar Company and Valhi, Inc., as amended and restated effective May 14, 1997 - incorporated by reference to Exhibit 10.9 to Valhi, Inc.'s Quarterly Report on Form 10-Q (File No. 1-5467) for the quarter ended June 30, 1997.

Item No.Exhibit Index

- 10.29 Second Amendment to the Subordinated Loan Agreement between Snake River Sugar Company and Valhi, Inc. dated November 30, 1998 - incorporated by reference to Exhibit 10.28 to Valhi, Inc.'s Annual Report on Form 10-K (File No. 1-5467) for the year ended December 31, 1998.
- 10.30 Third Amendment to the Subordinated Loan Agreement between Snake River Sugar Company and Valhi, Inc. dated October 19, 2000 - incorporated by reference to Exhibit 10.3 to Valhi, Inc.'s Quarterly Report on Form 10-Q (File No. 1-5467) for the quarter ended September 30, 2000.
- 10.31 Fourth Amendment to the Subordinated Loan Agreement between Snake River Sugar Company and Valhi, Inc. dated March 31, 2003 - incorporated by reference to Exhibit No. 10.1 to Valhi, Inc.'s Quarterly Report on Form 10-Q (file No. 1-5467) for the quarter ended March 31, 2003.
- 10.32 Contingent Subordinate Pledge Agreement between Snake River Sugar Company and Valhi, Inc., as acknowledged by First Security Bank National Association as Collateral Agent, dated October 19, 2000 - incorporated by reference to Exhibit 10.4 to Valhi, Inc.'s Quarterly Report on Form 10-Q (File No. 1-5467) for the quarter ended September 30, 2000.
- 10.33 Contingent Subordinate Security Agreement between Snake River Sugar Company and Valhi, Inc., as acknowledged by First Security Bank National Association as Collateral Agent, dated October 19, 2000 - incorporated by reference to Exhibit 10.5 to Valhi, Inc.'s Quarterly Report on Form 10-Q (File No. 1-5467) for the quarter ended September 30, 2000.
- 10.34 Contingent Subordinate Collateral Agency and Paying Agency Agreement among Valhi, Inc., Snake River Sugar Company and First Security Bank National Association dated October 19, 2000 - incorporated by reference to Exhibit 10.6 to Valhi, Inc.'s Quarterly Report on Form 10-Q (File No. 1-5467) for the quarter ended September 30, 2000.
- 10.35 Deposit Trust Agreement related to the Amalgamated Collateral Trust among ASC Holdings, Inc. and Wilmington Trust Company dated May 14, 1997 - incorporated by reference to Exhibit 10.2 to Valhi, Inc.'s Quarterly Report on Form 10-Q (File No. 1-5467) for the quarter ended June 30, 1997.
- 10.36 First Amendment to Deposit Trust Agreement dated October 14, 2005 among ASC Holdings, Inc. and Wilmington Trust Company - incorporated by reference to Exhibit No. 10.2 to Valhi, Inc.'s Amendment No. 1 to its Current Report on Form 8-K (File No. 1-5467) dated October 18, 2005.
- 10.37 Pledge Agreement between The Amalgamated Collateral Trust and Snake River Sugar Company dated May 14, 1997 - incorporated by reference to Exhibit 10.3 to Valhi, Inc.'s Quarterly Report on Form 10-Q (File No. 1-5467) for the quarter ended June 30, 1997.

Item No.Exhibit Index

- 10.38 Second Pledge Amendment (SPT) dated October 14, 2005 among The Amalgamated Collateral Trust and Snake River Sugar Company - incorporated by reference to Exhibit No. 10.4 to Valhi, Inc.'s Amendment No. 1 to its Current Report on Form 8-K (File No. 1-5467) dated October 18, 2005.
- 10.39 Guarantee by The Amalgamated Collateral Trust in favor of Snake River Sugar Company dated May 14, 1997 - incorporated by reference to Exhibit 10.4 to Valhi, Inc.'s Quarterly Report on Form 10-Q (File No. 1-5467) for the quarter ended June 30, 1997.
- 10.40 Second SPT Guaranty Amendment dated October 14, 2005 among The Amalgamated Collateral Trust and Snake River Sugar Company - incorporated by reference to Exhibit No. 10.5 to Valhi, Inc.'s Amendment No. 1 to its Current Report on Form 8-K (File No. 1-5467) dated October 18, 2005.
- 10.41 Voting Rights and Collateral Deposit Agreement among Snake River Sugar Company, Valhi, Inc., and First Security Bank, National Association dated May 14, 1997 - incorporated by reference to Exhibit 10.8 to Valhi, Inc.'s Quarterly Report on Form 10-Q (File No. 1-5467) for the quarter ended June 30, 1997.
- 10.42 Subordination Agreement between Valhi, Inc. and Snake River Sugar Company dated May 14, 1997 - incorporated by reference to Exhibit 10.10 to Valhi, Inc.'s Quarterly Report on Form 10-Q (File No. 1-5467) for the quarter ended June 30, 1997.
- 10.43 First Amendment to the Subordination Agreement between Valhi, Inc. and Snake River Sugar Company dated October 19, 2000 - incorporated by reference to Exhibit 10.7 to Valhi, Inc.'s Quarterly Report on Form 10-Q (File No. 1-5467) for the quarter ended September 30, 2000.
- 10.44 Form of Option Agreement among Snake River Sugar Company, Valhi, Inc. and the holders of Snake River Sugar Company's 10.9% Senior Notes Due 2009 dated May 14, 1997 - incorporated by reference to Exhibit 10.11 to the Valhi, Inc.'s Quarterly Report on Form 10-Q (File No. 1-5467) for the quarter ended June 30, 1997.
- 10.45 Option Agreement dated October 14, 2005 among Valhi, Inc., Snake River Sugar Company, Northwest Farm Credit Services, FLCA and U.S. Bank National Association - incorporated by reference to Exhibit No. 10.6 to Valhi, Inc.'s Amendment No. 1 to its Current Report on Form 8-K (File No. 1-5467) dated October 18, 2005.
- 10.46 First Amendment to Option Agreements among Snake River Sugar Company, Valhi Inc., and the holders of Snake River's 10.9% Senior Notes Due 2009 dated October 19, 2000 - incorporated by reference to Exhibit 10.8 to the Valhi, Inc.'s Quarterly Report on Form 10-Q (File No. 1-5467) for the quarter ended September 30, 2000.
- 10.47 Formation Agreement dated as of October 18, 1993 among Tioxide Americas Inc., Kronos Louisiana, Inc. and Louisiana Pigment Company, L.P. - incorporated by reference to Exhibit 10.2 of NL's Quarterly Report on Form 10-Q (File No. 1-640) for the quarter ended September 30, 1993.

Item No.Exhibit Index

- 10.48 Joint Venture Agreement dated as of October 18, 1993 between Tioxide Americas Inc. and Kronos Louisiana, Inc. - incorporated by reference to Exhibit 10.3 of NL's Quarterly Report on Form 10-Q (File No. 1-640) for the quarter ended September 30, 1993.
- 10.49 Kronos Offtake Agreement dated as of October 18, 1993 by and between Kronos Louisiana, Inc. and Louisiana Pigment Company, L.P. - incorporated by reference to Exhibit 10.4 of NL's Quarterly Report on Form 10-Q (File No. 1-640) for the quarter ended September 30, 1993.
- 10.50 Amendment No. 1 to Kronos Offtake Agreement dated as of December 20, 1995 between Kronos Louisiana, Inc. and Louisiana Pigment Company, L.P. - incorporated by reference to Exhibit 10.22 of NL's Annual Report on Form 10-K (File No. 1-640) for the year ended December 31 1995.
- 10.51 Allocation Agreement dated as of October 18, 1993 between Tioxide Americas Inc., ICI American Holdings, Inc., Kronos Worldwide, Inc. (f/k/a Kronos, Inc.) and Kronos Louisiana, Inc. - incorporated by reference to Exhibit 10.10 to NL's Quarterly Report on Form 10-Q (File No. 1-640) for the quarter ended September 30, 1993.
- 10.52 Lease Contract dated June 21, 1952, between Farbenfabriken Bayer Aktiengesellschaft and Titangesellschaft mit beschränkter Haftung (German language version and English translation thereof) - incorporated by reference to Exhibit 10.14 of NL's Annual Report on Form 10-K (File No. 1-640) for the year ended December 31, 1985.
- 10.53 Administrative Settlement for Interim Remedial Measures, Site Investigation and Feasibility Study dated July 7, 2000 between the Arkansas Department of Environmental Quality, Halliburton Energy Services, Inc., M I, LLC and TRE Management Company - incorporated by reference to Exhibit 10.1 to Tremont Corporation's Quarterly Report on Form 10-Q (File No. 1-10126) for the quarter ended June 30, 2002.
- 10.54 Reinstated and Amended Settlement Agreement and Release, dated June 26, 2008, by and among NL Industries, Inc., NL Environmental Management Services, Inc., the Sayreville Economic and Redevelopment Agency, Sayreville Seaport Associates, L.P., and the County of Middlesex. Certain schedules, exhibits, annexes and similar attachments to this Exhibit 10.1 have not been filed; upon request, Valhi, Inc. will furnish supplementally to the Commission a copy of any omitted exhibit, annex or attachment (incorporated by reference to Exhibit 10.1 to NL's Current Report on NL's Form 8-K, File No. 1-640, that was filed with the U.S. Securities and Exchange Commission on October 16, 2008).
- 10.55 Amendment to Restated and Amended Settlement Agreement and Release, dated September 25, 2008 by and among NL Industries, Inc., NL Environmental Management Services, Inc., the Sayreville Economic and Redevelopment Agency, Sayreville Seaport Associates, L.P., and the County of Middlesex (incorporated by reference to Exhibit 10.2 to NL's Current Report on Form 8-K, File No. 1-640, that was filed with the U.S. Securities and Exchange Commission on October 16, 2008).

Item No.Exhibit Index

- 10.56 Mortgage Note, dated October 15, 2008 by Sayreville Seaport Associates, L.P. in favor of NL Industries, Inc. and NL Environmental Management Services, Inc (incorporated by reference to Exhibit 10.3 to NL's Current Report on Form 8-K, File No. 1-640, that was filed with the U.S. Securities and Exchange Commission on October 16, 2008).
- 10.57 Leasehold Mortgage, Assignment, Security Agreement and Fixture Filing, dated October 15, 2008, by Sayreville Seaport Associates, L.P. in favor of NL Industries, Inc. and NL Environmental Management Services, Inc. Certain schedules, exhibits, annexes and similar attachments to this Exhibit 10.4 have not been filed; upon request, Valhi, Inc. will furnish supplementally to the Commission a copy of any omitted exhibit, annex or attachment (incorporated by reference to Exhibit 10.4 to NL's Current Report on Form 8-K, File No. 1-640, that was filed with the U.S. Securities and Exchange Commission on October 16, 2008).
- 10.58 Intercreditor, Subordination and Standstill Agreement, dated October 15, 2008, by NL Industries, Inc., NL Environmental Management Services, Inc., Bank of America, N.A. on behalf of itself and the other financial institutions, and acknowledged and consented to by Sayreville Seaport Associates, L.P. and J. Brian O'Neill. Certain schedules, exhibits, annexes and similar attachments to this Exhibit 10.5 have not been filed; upon request, Valhi, Inc. will furnish supplementally to the Commission a copy of any omitted exhibit, annex or attachment (incorporated by reference to Exhibit 10.5 to NL's Current Report on Form 8-K, File No. 1-640, that was filed with the U.S. Securities and Exchange Commission on October 16, 2008).
- 10.59 Multi Party Agreement, dated October 15, 2008 by and among Sayreville Seaport Associates, L.P., Sayreville Seaport Associates Acquisition Company, LLC, OPG Participation, LLC, J. Brian O'Neill, NL Industries, Inc., NL Environmental Management Services, Inc., The Prudential Insurance Company of America, Sayreville PRISA II LLC. Certain schedules, exhibits, annexes and similar attachments to this Exhibit 10.6 have not been filed; upon request, Valhi, Inc. will furnish supplementally to the Commission a copy of any omitted exhibit, annex or attachment (incorporated by reference to Exhibit 10.6 to NL's Current Report on Form 8-K, File No. 1-640, that was filed with the U.S. Securities and Exchange Commission on October 16, 2008).
- 10.60 Guaranty Agreement, dated October 15, 2008, by J. Brian O'Neill in favor of NL Industries, Inc. and NL Environmental Management Services, Inc (incorporated by reference to Exhibit 10.7 to NL's Current Report on Form 8-K, File No. 1-640, that was filed with the U.S. Securities and Exchange Commission on October 16, 2008).
- 21.1** Subsidiaries of Valhi, Inc..
- 23.1** Consent of PricewaterhouseCoopers LLP with respect to Valhi's Consolidated Financial Statements
- 23.2** Consent of PricewaterhouseCoopers LLP with respect to TIMET's Consolidated Financial Statements
- 31.1** Certification

Item No.

Exhibit Index

31.2** Certification

32.1** Certification

99.1 Consolidated financial statements of Titanium Metals Corporation incorporated by reference to TIMET's Annual Report on Form 10-K (File No. 0-28538) for the year ended December 31, 2008.

* Management contract, compensatory plan or agreement.

** Filed herewith.

SIGNATURES

Pursuant to the requirements of Section 13 or 15(d) of the Securities Exchange Act of 1934, the Registrant has duly caused this report to be signed on its behalf by the undersigned, thereunto duly authorized.

VALHI, INC.
(Registrant)

By: /s/ Steven L. Watson
Steven L. Watson, March 12, 2009
(President and Chief Executive Officer)

Pursuant to the requirements of the Securities Exchange Act of 1934, this report has been signed below by the following persons on behalf of the Registrant and in the capacities and on the dates indicated:

/s/ Harold C. Simmons
Harold C. Simmons, March 12, 2009
(Chairman of the Board)

/s/ Steven L. Watson
Steven L. Watson, March 12, 2009
(President, Chief Executive Officer
and Director)

/s/ Thomas E. Barry
Thomas E. Barry, March 12, 2009
(Director)

/s/ Glenn R. Simmons
Glenn R. Simmons, March 12, 2009
(Vice Chairman of the Board)

/s/ Norman S. Edelcup
Norman S. Edelcup, March 12, 2009
(Director)

/s/ Bobby D. O'Brien
Bobby D. O'Brien, March 12, 2009
(Vice President and Chief Financial
Officer, Principal Financial
Officer)

/s/ W. Hayden McIlroy
W. Hayden McIlroy, March 12, 2009
(Director)

/s/ Gregory M. Swalwell
Gregory M. Swalwell, March 12, 2009
(Vice President and Controller,
Principal Accounting Officer)

/s/ J. Walter Tucker, Jr.
J. Walter Tucker, Jr. March 12, 2009
(Director)

SUBSIDIARIES OF THE REGISTRANT

<u>Name of Corporation</u>	<u>Jurisdiction Of Incorporation or Organization</u>	<u>% of Voting Securities Held at December 31, 2008 (1)</u>
Amcorp, Inc.	Delaware	100%
ASC Holdings, Inc.	Utah	100%
Amalgamated Research, Inc.	Idaho	100%
Andrews County Holdings, Inc.	Delaware	100%
Waste Control Specialists LLC	Delaware	100%
Kronos Worldwide, Inc. (2)	Delaware	59%
NL Industries, Inc. (2), (3), (4)	New Jersey	83%
CompX International Inc. (4)	Delaware	87%
Tremont LLC	Delaware	100%
TRECO L.L.C.	Nevada	100%
Basic Management, Inc.	Nevada	32%
Basic Water Company	Nevada	100%
Basic Environmental Control LLC	Nevada	100%
Basic Power Company	Nevada	100%
Basic Remediation Company LLC	Nevada	100%
Basic Land Company	Nevada	100%
The Landwell Company LP	Delaware	50%
The Landwell Company LP	Delaware	12%
TRE Holding Corporation	Delaware	100%
TRE Management Company	Delaware	100%
Tall Pines Insurance Company	Vermont	100%
Medite Corporation	Delaware	100%
Impex Realty Holding, Inc.	Delaware	100%

- (1) Held by the Registrant or the indicated subsidiary of the Registrant.
- (2) Subsidiaries of Kronos are incorporated by reference to Exhibit 21.1 of Kronos' Annual Report on Form 10-K for the year ended December 31, 2008 (File No. 333-100047). NL owns an additional 36% of Kronos directly.
- (3) Subsidiaries of NL are incorporated by reference to Exhibit 21.1 of NL's Annual Report on Form 10-K for the year ended December 31, 2008 (File No. 1-640).
- (4) Subsidiaries of CompX are incorporated by reference to Exhibit 21.1 of CompX's Annual Report on Form 10-K for the year ended December 31, 2008 (File No. 1-13905).

Annual Report on Form 10-K

Items 8, 15(a) and 15(c)

Index of Financial Statements and Schedule

Financial Statements	Page
Report of Independent Registered Public Accounting Firm	F-2
Consolidated Balance Sheets - December 31, 2007 and 2008	F-4
Consolidated Statements of Operations - Years ended December 31, 2006, 2007 and 2008	F-6
Consolidated Statements of Comprehensive Income (Loss) - Years ended December 31, 2006, 2007 and 2008	F-7
Consolidated Statements of Stockholders' Equity - Years ended December 31, 2006, 2007 and 2008	F-9
Consolidated Statements of Cash Flows - Years ended December 31, 2006, 2007 and 2008	F-10
Notes to Consolidated Financial Statements	F-13

Financial Statement Schedule

Schedule I - Condensed Financial Information of Registrant	S-1
--	-----

We omitted Schedules II, III and IV because they are not applicable or the required amounts are either not material or are presented in the Notes to the Consolidated Financial Statements.

REPORT OF INDEPENDENT REGISTERED PUBLIC ACCOUNTING FIRM

To the Stockholders and Board of Directors of Valhi, Inc.:

In our opinion, the accompanying consolidated balance sheets and the related consolidated statements of operations, of comprehensive income (loss), of changes in stockholders' equity and of cash flows present fairly, in all material respects, the financial position of Valhi, Inc. and its subsidiaries at December 31, 2007 and 2008 and the results of their operations and their cash flows for each of the three years in the period ended December 31, 2008 in conformity with accounting principles generally accepted in the United States of America. In addition, in our opinion, the financial statement schedule listed in the accompanying index presents fairly, in all material respects, the information set forth therein when read in conjunction with the related consolidated financial statements. Also in our opinion, the Company maintained, in all material respects, effective internal control over financial reporting as of December 31, 2008, based on criteria established in Internal Control - Integrated Framework issued by the Committee of Sponsoring Organizations of the Treadway Commission (COSO). The Company's management is responsible for these financial statements and financial statement schedule, for maintaining effective internal control over financial reporting and for its assessment of the effectiveness of internal control over financial reporting, included in the accompanying Management's Report on Internal Control Over Financial Reporting under Item 9A. Our responsibility is to express opinions on these financial statements, on the financial statement schedule and on the Company's internal control over financial reporting based on our integrated audits. We conducted our audits in accordance with the standards of the Public Company Accounting Oversight Board (United States). Those standards require that we plan and perform the audits to obtain reasonable assurance about whether the financial statements are free of material misstatement and whether effective internal control over financial reporting was maintained in all material respects. Our audits of the financial statements included examining, on a test basis, evidence supporting the amounts and disclosures in the financial statements, assessing the accounting principles used and significant estimates made by management, and evaluating the overall financial statement presentation. Our audit of internal control over financial reporting included obtaining an understanding of internal control over financial reporting, assessing the risk that a material weakness exists, and testing and evaluating the design and operating effectiveness of internal control based on the assessed risk. Our audits also included performing such other procedures as we considered necessary in the circumstances. We believe that our audits provide a reasonable basis for our opinions.

As discussed in Note 11 and Note 18 to the Consolidated Financial Statements, the Company changed the manner in which it accounts for pension and other postretirement benefit obligations in 2006 and the manner in which it accounts for uncertain tax positions in 2007, respectively.

A company's internal control over financial reporting is a process designed to provide reasonable assurance regarding the reliability of financial reporting and the preparation of financial statements for external purposes in accordance with generally accepted accounting principles. A company's internal control over financial reporting includes those policies

and procedures that (i) pertain to the maintenance of records that, in reasonable detail, accurately and fairly reflect the transactions and dispositions of the assets of the company; (ii) provide reasonable assurance that transactions are recorded as necessary to permit preparation of financial statements in accordance with generally accepted accounting principles, and that receipts and expenditures of the company are being made only in accordance with authorizations of management and directors of the company; and (iii) provide reasonable assurance regarding prevention or timely detection of unauthorized acquisition, use, or disposition of the company's assets that could have a material effect on the financial statements.

Because of its inherent limitations, internal control over financial reporting may not prevent or detect misstatements. Also, projections of any evaluation of effectiveness to future periods are subject to the risk that controls may become inadequate because of changes in conditions, or that the degree of compliance with the policies or procedures may deteriorate.

PricewaterhouseCoopers LLP

March 12, 2009

VALHI, INC. AND SUBSIDIARIES

CONSOLIDATED BALANCE SHEETS

(In millions)

ASSETS	December 31,	
	<u>2007</u>	<u>2008</u>
Current assets:		
Cash and cash equivalents	\$ 138.3	\$ 37.0
Restricted cash equivalents	7.2	9.4
Marketable securities	7.2	8.8
Accounts and other receivables, net	241.4	203.5
Refundable income taxes	7.7	1.6
Receivable from affiliates	4.6	.1
Inventories, net	337.9	408.5
Prepaid expenses and other	16.2	15.4
Deferred income taxes	10.4	12.1
Total current assets	<u>770.9</u>	<u>696.4</u>
Other assets:		
Marketable securities	319.8	275.5
Investment in affiliates	137.9	124.0
Pension asset	47.6	-
Goodwill	406.8	396.8
Other intangible assets	2.7	2.0
Deferred income taxes	168.7	166.4
Other assets	67.3	87.3
Total other assets	<u>1,150.8</u>	<u>1,052.0</u>
Property and equipment:		
Land	48.2	46.4
Buildings	277.1	268.5
Equipment	1,051.9	1,025.3
Mining properties	39.8	30.3
Construction in progress	48.9	58.2
	<u>1,465.9</u>	<u>1,428.7</u>
Less accumulated depreciation	784.6	787.7
Net property and equipment	<u>681.3</u>	<u>641.0</u>
Total assets	<u>\$2,603.0</u>	<u>\$2,389.4</u>

VALHI, INC. AND SUBSIDIARIES

CONSOLIDATED BALANCE SHEETS (CONTINUED)

(In millions, except share data)

LIABILITIES AND STOCKHOLDERS' EQUITY	December 31,	
	2007	2008
Current liabilities:		
Current maturities of long-term debt	\$ 16.8	\$ 9.4
Accounts payable	115.6	121.0
Accrued liabilities	133.2	128.4
Payable to affiliates	19.0	25.8
Income taxes	9.8	4.9
Deferred income taxes	3.3	4.7
Total current liabilities	<u>297.7</u>	<u>294.2</u>
Noncurrent liabilities:		
Long-term debt	889.8	911.0
Deferred income taxes	415.0	346.6
Accrued pension costs	140.0	146.1
Accrued environmental costs	40.3	41.3
Accrued postretirement benefits cost	33.6	29.3
Other	77.7	78.8
Total noncurrent liabilities	<u>1,596.4</u>	<u>1,553.1</u>
Minority interest in net assets of subsidiaries	<u>90.5</u>	<u>73.3</u>
Stockholders' equity:		
Preferred stock, \$.01 par value; 5,000 shares authorized; 5,000 shares issued	667.3	667.3
Common stock, \$.01 par value; 150.0 million shares authorized; 118.4 million shares issued	1.2	1.2
Additional paid-in capital	10.4	-
Retained deficit	(74.1)	(109.8)
Accumulated other comprehensive income (loss)	51.5	(51.0)
Treasury stock, at cost - 4.0 million and 4.1 million shares	(37.9)	(38.9)
Total stockholders' equity	<u>618.4</u>	<u>468.8</u>
Total liabilities, minority interest and stockholders' equity	<u>\$2,603.0</u>	<u>\$2,389.4</u>

Commitments and contingencies (Notes 4, 9, 12, 16 and 17)

See accompanying Notes to Consolidated Financial Statements.

VALHI, INC. AND SUBSIDIARIES
CONSOLIDATED STATEMENTS OF OPERATIONS

(In millions, except per share data)

	Years ended December 31,		
	2006	2007	2008
Revenues and other income:			
Net sales	\$1,481.4	\$1,492.2	\$1,485.3
Other income, net	89.9	42.3	93.7
Equity in earnings of:			
Titanium Metals Corporation ("TIMET")	101.1	26.9	-
Other	3.8	1.7	(1.0)
Total revenues and other income	1,676.2	1,563.1	1,578.0
Costs and expenses:			
Cost of goods sold	1,139.4	1,206.3	1,239.1
Selling, general and administrative	229.4	238.4	238.5
Goodwill impairment	-	-	10.1
Loss on prepayment of debt	22.3	-	-
Interest	67.6	64.4	68.7
Total costs and expenses	1,458.7	1,509.1	1,556.4
Income before taxes	217.5	54.0	21.6
Provision for income taxes	63.8	103.2	16.7
Minority interest in after-tax earnings (losses)	12.0	(3.5)	5.7
Net income (loss)	\$ 141.7	\$ (45.7)	\$ (.8)
Net income (loss) per share:			
Basic	\$ 1.22	\$ (.40)	\$ (.01)
Diluted	1.20	(.40)	(.01)
Cash dividends per share	.40	.40	.40
Weighted average shares outstanding:			
Basic	116.1	114.7	114.4
Diluted	116.5	114.7	114.4

See accompanying Notes to Consolidated Financial Statements.

VALHI, INC. AND SUBSIDIARIES

CONSOLIDATED STATEMENTS OF COMPREHENSIVE INCOME (LOSS)

(In millions)

	<u>Years ended December 31,</u>		
	<u>2006</u>	<u>2007</u>	<u>2008</u>
Net income (loss)	<u>\$141.7</u>	<u>\$(45.7)</u>	<u>\$ (.8)</u>
Other comprehensive income (loss), net of tax:			
Marketable securities	2.0	23.3	(22.8)
Currency translation	27.5	29.4	(33.6)
Defined benefit pension plans	5.6	32.1	(47.3)
Other postretirement benefit plans	<u>-</u>	<u>.6</u>	<u>1.2</u>
Total other comprehensive income (loss), net	<u>35.1</u>	<u>85.4</u>	<u>(102.5)</u>
Comprehensive income (loss)	<u>\$176.8</u>	<u>\$ 39.7</u>	<u>\$(103.3)</u>

VALHI, INC. AND SUBSIDIARIES

CONSOLIDATED STATEMENTS OF COMPREHENSIVE INCOME (LOSS) (CONTINUED)

(In millions)

	Years ended December 31,		
	<u>2006</u>	<u>2007</u>	<u>2008</u>
Accumulated other comprehensive income (net of tax):			
Marketable securities:			
Balance at beginning of year	\$ 4.2	\$ 6.2	\$ 27.1
Other comprehensive income (loss)	2.0	23.3	(22.8)
TIMET distribution	-	(2.4)	-
Balance at end of year	<u>\$ 6.2</u>	<u>\$ 27.1</u>	<u>\$ 4.3</u>
Currency translation:			
Balance at beginning of year	\$ 11.6	\$ 39.1	\$ 64.5
Other comprehensive income (loss)	27.5	29.4	(33.6)
TIMET distribution	-	(4.0)	-
Balance at end of year	<u>\$ 39.1</u>	<u>\$ 64.5</u>	<u>\$ 30.9</u>
Minimum pension liabilities:			
Balance at beginning of year	\$ (78.1)	\$ -	\$ -
Other comprehensive income	5.6	-	-
Adoption of SFAS No. 158	72.5	-	-
Balance at end of year	<u>\$ -</u>	<u>\$ -</u>	<u>\$ -</u>
Defined benefit pension plans:			
Balance at beginning of year	\$ -	\$ (85.0)	\$ (38.8)
Other comprehensive income (loss):			
Amortization of prior service cost and net losses included in net periodic pension cost	-	4.1	.1
Net actuarial gain (loss) arising during year	-	28.0	(47.4)
Adoption of SFAS No. 158	(85.0)	1.2	-
TIMET distribution	-	12.9	-
Balance at end of year	<u>\$ (85.0)</u>	<u>\$ (38.8)</u>	<u>\$ (86.1)</u>
OPEB plans:			
Balance at beginning of year	\$ -	\$ (3.4)	\$ (1.3)
Other comprehensive income (loss):			
Amortization of prior service cost and net losses included in net periodic pension cost	-	-	(.1)
Net actuarial gain arising during year	-	.6	1.3
Adoption of SFAS No. 158	(3.4)	-	-
TIMET distribution	-	1.5	-
Balance at end of year	<u>\$ (3.4)</u>	<u>\$ (1.3)</u>	<u>\$ (.1)</u>
Total accumulated other comprehensive income (loss):			
Balance at beginning of year	\$ (62.3)	\$ (43.1)	\$ 51.5
Other comprehensive income (loss)	35.1	85.4	(102.5)
Adoption of SFAS No. 158	(15.9)	1.2	-
TIMET distribution	-	8.0	-
Balance at end of year	<u>\$ (43.1)</u>	<u>\$ 51.5</u>	<u>\$ (51.0)</u>

See accompanying Notes to Consolidated Financial Statements.

VALHI, INC. AND SUBSIDIARIES
CONSOLIDATED STATEMENTS OF STOCKHOLDERS' EQUITY
Years ended December 31, 2006, 2007 and 2008
(In millions)

	Preferred stock	Common stock	Additional paid-in capital	Retained earnings (deficit)	Accumulated other comprehensive income (loss)	Treasury stock	Total stockholders' equity
Balance at December 31, 2005	\$ -	\$1.2	\$108.8	\$ 787.6	\$ (62.3)	\$(37.9)	\$ 797.4
Net income	-	-	-	141.7	-	-	141.7
Cash dividends	-	-	-	(48.0)	-	-	(48.0)
Other comprehensive income, net	-	-	-	-	35.1	-	35.1
Change in accounting SFAS No. 158 - asset and liability recognition provisions of SFAS No. 158	-	-	-	-	(15.9)	-	(15.9)
Treasury stock:							
Acquired	-	-	-	-	-	(43.8)	(43.8)
Retired	-	-	(1.7)	(42.1)	-	43.8	-
Other, net	-	-	.3	-	-	-	.3
Balance at December 31, 2006	-	1.2	107.4	839.2	(43.1)	(37.9)	866.8
Net loss	-	-	-	(45.7)	-	-	(45.7)
Cash dividends	-	-	(34.2)	(11.4)	-	-	(45.6)
Dividend of TIMET common stock	-	-	(55.0)	(850.4)	8.0	-	(897.4)
Change in accounting:							
FIN No. 48	-	-	-	(1.6)	-	-	(1.6)
SFAS No. 158 - measurement date provisions	-	-	-	(2.2)	1.2	-	(1.0)
Issuance of preferred stock	667.3	-	-	-	-	-	667.3
Other comprehensive income, net	-	-	-	-	85.4	-	85.4
Treasury stock:							
Acquired	-	-	-	-	-	(11.1)	(11.1)
Retired	-	-	(9.2)	(1.9)	-	11.1	-
Other, net	-	-	1.4	(1.1)	-	-	1.3
Balance at December 31, 2007	667.3	1.2	10.4	(74.1)	51.5	(37.9)	618.4
Net loss	-	-	-	(1.9)	-	-	(1.9)
Cash dividends	-	-	-	(35.1)	-	-	(35.1)
Other comprehensive loss, net	-	-	-	-	(102.5)	-	(102.5)
Treasury stock acquired	-	-	-	-	-	(1.0)	(1.0)
Other, net	-	-	-	.2	-	-	.2
Balance at December 31, 2008	<u>\$667.3</u>	<u>\$1.2</u>	<u>\$ -</u>	<u>\$(109.8)</u>	<u>\$ (51.0)</u>	<u>\$(38.9)</u>	<u>\$ 468.8</u>

See accompanying Notes to Consolidated Financial Statements.
F-9

VALHI, INC. AND SUBSIDIARIES

CONSOLIDATED STATEMENTS OF CASH FLOWS

(In millions)

	<u>Years ended December 31,</u>		
	<u>2006</u>	<u>2007</u>	<u>2008</u>
Cash flows from operating activities:			
Net income (loss)	\$ 141.7	\$ (45.7)	\$ (.8)
Depreciation and amortization	72.5	66.3	66.1
Securities transactions, net	(.7)	.1	1.2
Gain on litigation settlement	-	-	(47.9)
Goodwill impairment	-	-	10.1
Loss on prepayment of debt	22.3	-	-
Call premium paid on redemption of Senior Secured Notes	(20.9)	-	-
Loss (gain) on disposal of property and equipment	(35.3)	1.3	1.0
Noncash interest expense	2.0	1.6	2.1
Benefit plan expense greater (less) than cash funding requirements:			
Defined benefit pension expense	(5.3)	(4.6)	(22.3)
Other postretirement benefit expense	(1.5)	.9	.9
Deferred income taxes	37.3	86.4	(12.4)
Minority interest	12.0	(3.5)	5.7
Equity in:			
TIMET	(101.1)	(26.9)	-
Other	(3.9)	(1.7)	1.0
Net distributions from (contributions to):			
TiO ₂ manufacturing joint venture	2.3	(4.9)	10.0
Other	2.3	1.0	-
Other, net	1.0	1.9	2.7
Change in assets and liabilities:			
Accounts and other receivables, net	8.2	9.1	15.0
Inventories, net	(3.8)	3.9	(93.0)
Accounts payable and accrued liabilities	(6.8)	(4.8)	15.6
Income taxes	(21.1)	(9.6)	2.7
Accounts with affiliates	1.4	(2.0)	10.5
Other noncurrent assets	6.0	(2.7)	(3.5)
Other noncurrent liabilities	(13.8)	(4.3)	5.3
Other, net	(8.5)	1.7	5.5
Net cash provided by (used in) operating activities	<u>\$ 86.3</u>	<u>\$ 63.5</u>	<u>\$ (24.5)</u>

VALHI, INC. AND SUBSIDIARIES

CONSOLIDATED STATEMENTS OF CASH FLOWS (CONTINUED)

(In millions)

	Years ended December 31,		
	<u>2006</u>	<u>2007</u>	<u>2008</u>
Cash flows from investing activities:			
Capital expenditures	\$ (63.8)	\$ (63.8)	\$ (84.9)
Purchases of:			
Kronos common stock	(25.4)	-	(.8)
TIMET common stock	(18.7)	(.7)	-
CompX common stock	(2.3)	(3.3)	(1.0)
NL common stock	(.4)	-	-
Business units	(9.8)	-	-
Marketable securities	(43.4)	(23.3)	(6.1)
Capitalized permit costs	(8.3)	(7.1)	(13.8)
Proceeds from disposal of:			
Marketable securities	42.9	28.5	7.9
Property and equipment	39.4	.6	.3
Change in restricted cash equivalents, net	(2.9)	2.4	(2.5)
Proceeds from real estate-related litigation settlement	-	-	39.6
Other, net	<u>3.2</u>	<u>1.3</u>	<u>1.3</u>
Net cash used in investing activities	<u>(89.5)</u>	<u>(65.4)</u>	<u>(60.0)</u>
Cash flows from financing activities:			
Indebtedness:			
Borrowings	772.7	331.1	427.7
Principal payments	(751.6)	(324.4)	(385.6)
Deferred financing costs paid	(9.0)	-	(1.2)
Valhi cash dividends paid	(48.0)	(45.6)	(45.5)
Distributions to minority interest	(8.9)	(8.5)	(7.3)
Treasury stock acquired	(43.8)	(11.1)	(1.0)
NL common stock issued	.1	-	-
Issuance of Valhi common stock and other, net	<u>.9</u>	<u>2.4</u>	<u>-</u>
Net cash used in financing activities	<u>(87.6)</u>	<u>(56.1)</u>	<u>(12.9)</u>
Net decrease	<u>\$ (90.8)</u>	<u>\$ (58.0)</u>	<u>\$ (97.4)</u>

VALHI, INC. AND SUBSIDIARIES

CONSOLIDATED STATEMENTS OF CASH FLOWS (CONTINUED)

(In millions)

	<u>Years ended December 31,</u>		
	<u>2006</u>	<u>2007</u>	<u>2008</u>
Cash and cash equivalents - net change from:			
Operating, investing and financing			
Activities	\$ (90.8)	\$ (58.0)	\$ (97.4)
Currency translation	<u>5.0</u>	<u>7.1</u>	<u>(3.9)</u>
Net change for the year	(85.8)	(50.9)	(101.3)
Balance at beginning of year	<u>275.0</u>	<u>189.2</u>	<u>138.3</u>
Balance at end of year	<u>\$189.2</u>	<u>\$138.3</u>	<u>\$ 37.0</u>
Supplemental disclosures:			
Cash paid for:			
Interest, net of amounts capitalized	\$ 57.9	\$ 62.5	\$ 66.7
Income taxes, net	42.9	32.3	15.2
Noncash investing activities:			
Accruals for capital expenditures	-	9.7	12.7
Accruals for capitalized permits	1.0	.3	.7
Note receivable from legal settlement	-	-	15.0
Noncash financing activities:			
Dividend of TIMET common stock	-	897.4	-
Issuance of preferred stock in settlement of tax obligation	-	667.3	-
Issuance of note payable to TIMET for acquisition of minority interest	-	52.6	-

See accompanying Notes to Consolidated Financial Statements.

VALHI, INC. AND SUBSIDIARIES

NOTES TO CONSOLIDATED FINANCIAL STATEMENTS

December 31, 2008

Note 1 - Summary of significant accounting policies:

Nature of our business. Valhi, Inc. (NYSE: VHI) is primarily a holding company. We operate through our wholly-owned and majority-owned subsidiaries, including NL Industries, Inc., Kronos Worldwide, Inc., CompX International Inc., Tremont LLC and Waste Control Specialists LLC ("WCS"). Prior to March 26, 2007 we were the largest shareholder of Titanium Metals Corporation ("TIMET") although we owned less than a majority interest. See Note 3. Kronos (NYSE: KRO), NL (NYSE: NL), and CompX (NYSE: CIX) each file periodic reports with the Securities and Exchange Commission ("SEC").

Organization. We are majority owned by Contran Corporation, which through subsidiaries owns approximately 94% of our outstanding common stock at December 31, 2008. Substantially all of Contran's outstanding voting stock is held by trusts established for the benefit of certain children and grandchildren of Harold C. Simmons (for which Mr. Simmons is the sole trustee) or is held directly by Mr. Simmons or other persons or entities related to Mr. Simmons. Consequently, Mr. Simmons may be deemed to control Contran and us.

Unless otherwise indicated, references in this report to "we," "us" or "our" refer to Valhi, Inc and its subsidiaries, taken as a whole.

Management's estimates. The preparation of our Consolidated Financial Statements in conformity with accounting principles generally accepted in the United States of America ("GAAP"), requires us to make estimates and assumptions that affect the reported amounts of our assets and liabilities and disclosures of contingent assets and liabilities at each balance sheet date and the reported amounts of our revenues and expenses during each reporting period. Actual results may differ significantly from previously-estimated amounts under different assumptions or conditions.

Certain reclassifications have been made to conform the prior year's Consolidated Financial Statements to the current year's classifications. At December 31, 2007 we originally classified approximately \$12.2 million with our noncurrent reserve for uncertain tax positions which should have been classified with our noncurrent deferred income tax liability; the Consolidated Balance Sheet and related disclosures at December 31, 2007, as presented herein, has properly classified such \$12.2 million with our noncurrent deferred income tax liability.

Principles of consolidation. Our consolidated financial statements include the financial position, results of operations and cash flows of Valhi and our majority-owned and wholly-owned subsidiaries. We eliminate all material intercompany accounts and balances.

We account for increases in our ownership interest of our consolidated subsidiaries and equity method investees, either through our purchase of additional shares of their common stock or through their purchase of their own shares of common stock, by the purchase method (step acquisition). Unless otherwise noted, such purchase accounting generally results in an adjustment to the carrying amount of goodwill for our consolidated subsidiaries. We account for decreases in our ownership interest of our consolidated subsidiaries and equity method investees through cash sales of their common stock to third parties (either by us or by our subsidiary) by recognizing a gain or loss in net income equal to the difference between the proceeds from such sale and the carrying value of the shares sold. The effect of other decreases in our ownership interest, which is usually the result of employee stock options exercises, is generally not material. See Note 18.

Foreign currency translation. The financial statements of our foreign subsidiaries are translated to U.S. dollars in accordance with the provisions of Statement of Financial Accounting Standards ("SFAS") No. 52 "Foreign Currency Translation." The functional currency of our foreign subsidiaries is generally the local currency of the country. Accordingly, we translate the assets and liabilities at year-end rates of exchange, while we translate their revenues and expenses at average exchange rates prevailing during the year. We accumulate the resulting translation adjustments in stockholders' equity as part of accumulated other comprehensive income (loss), net of related deferred income taxes and minority interest. We recognize currency transaction gains and losses in income.

Derivatives and hedging activities. We recognize derivatives as either an asset or liability measured at fair value in accordance with SFAS No. 133, *Accounting for Derivative Instruments and Hedging Activities*, as amended and interpreted. We recognize the effect of changes in the fair value of derivatives either in net income or other comprehensive income, depending on the intended use of the derivative.

Cash and cash equivalents. We classify bank time deposits and government and commercial notes and bills with original maturities of three months or less as cash equivalents.

Restricted cash equivalents and marketable debt securities. We classify cash equivalents and marketable debt securities that have been segregated or are otherwise limited in use as restricted. To the extent the restricted amount relates to a recognized liability, we classify the restricted amount as current or noncurrent according to the corresponding liability. To the extent the restricted amount does not relate to a recognized liability, we classify restricted cash as a current asset and we classify the restricted debt security as either a current or noncurrent asset depending upon the maturity date of the security. See Note 4.

Marketable securities; securities transactions. We carry marketable debt and equity securities at fair value. We adopted SFAS No. 157, *Fair Value Measurements*, which establishes a framework for measuring fair value on January 1, 2008. The statement requires fair value measurements to be classified and disclosed in one of the following three categories:

- **Level 1** - Unadjusted quoted prices in active markets that are accessible at the measurement date for identical, unrestricted assets or liabilities;
- **Level 2** - Quoted prices in markets that are not active, or inputs which are observable, either directly or indirectly, for substantially the full term of the assets or liability; and
- **Level 3** - Prices or valuation techniques that require inputs that are both significant to the fair value measurement and unobservable.

See Notes 4 and 19. We recognize unrealized and realized gains and losses on trading securities in income. We accumulate unrealized gains and losses on available-for-sale securities as part of accumulated other comprehensive income, net of related deferred income taxes and minority interest. Realized gains and losses are based on specific identification of the securities sold.

Accounts receivable. We provide an allowance for doubtful accounts for known and estimated potential losses arising from our sales to customers based on a periodic review of these accounts.

Inventories and cost of sales. We state inventories at the lower of cost or market, net of allowance for obsolete and slow-moving inventories. We generally base inventory costs on average cost or the first-in, first-out method. Unallocated overhead costs resulting from periods with abnormally low production levels are charged to expense as incurred. Our cost of sales includes costs for materials, packing and finishing, utilities, salary and benefits, maintenance and depreciation.

Investment in affiliates and joint ventures. We account for investments in more than 20%-owned but less than majority-owned companies by the equity method. See Note 7. We allocate any differences between the cost of each investment and our pro-rata share of the entity's separately-reported net assets among the assets and liabilities of the entity based upon estimated relative fair values. We amortize these differences, which were not material at December 31, 2008, to income as the entities depreciate, amortize or dispose of the related net assets.

Goodwill and other intangible assets; amortization expense. We account for goodwill and other intangible assets in accordance with SFAS No. 142, *Goodwill and Other Intangible Assets*. Goodwill represents the excess of cost over fair value of individual net assets acquired in business combinations accounted for by the purchase method. Goodwill is not subject to periodic amortization. We amortize other intangible assets by the straight-line method over their estimated lives and state them net of accumulated amortization. We evaluate goodwill for impairment, annually, or when circumstances indicate the carrying value may not be recoverable. See Note 8.

We amortize patents by the straight-line method over their estimated useful lives of 20 years.

Capitalized operating permits. Our Waste Management Segment capitalizes direct costs for the acquisition or renewal of operating permits and amortizes these costs by the straight-line method over the term of the applicable permit. Amortization of capitalized operating permit costs was \$.1 million in each of 2006 and 2007 and \$.2 million in 2008. At December 31, 2008, net capitalized operating permit costs include (i) \$.7 million in costs to renew certain permits for which the renewal application is pending with the applicable regulatory agency, (ii) \$8.0 million for issued permits and (iii) \$33.5 million in costs to apply for certain new permits which have not yet been issued by the applicable regulatory authority. We currently expect renewal of the permits for which the application is still pending will occur in the ordinary course of business, and we have been amortizing costs related to these renewals from the date the prior permit expired. For costs related to the newly issued permits and permits that have not yet been issued, we will either (i) amortize such costs from the date the permit is issued or (ii) write off such costs to expense at the earlier of (a) the date the applicable regulatory authority rejects the permit application or (b) the date we determine issuance of the permit is not probable. All operating permits are generally subject to renewal at the option of the issuing governmental agency.

Property and equipment; depreciation expense. We state property and equipment at acquisition cost, including capitalized interest on borrowings during the actual construction period of major capital projects. We did not capitalize any material interest costs in 2006. In 2007 and 2008 we capitalized \$.7 million and \$2.2 million, respectively, in interest costs. We compute depreciation of property and equipment for financial reporting purposes (including mining properties) principally by the straight-line method over the estimated useful lives of the assets as follows:

<u>Asset</u>	<u>Useful lives</u>
Buildings and improvements	10 to 40 years
Machinery and equipment	3 to 20 years

We expense expenditures for maintenance, repairs and minor renewals as incurred that do not improve or extend the life of the assets, including planned major maintenance.

We have a governmental concession with an unlimited term to operate an ilmenite mine in Norway. Mining properties consist of buildings and equipment used in our Norwegian ilmenite mining operations. While we own the land associated with the mining operation and ilmenite reserves associated with the mine, such land and reserves were acquired for nominal value and we have no material asset recognized for the land and reserves related to such mining operations.

We perform impairment tests when events or changes in circumstances indicate the carrying value may not be recoverable. We consider all relevant factors. We perform the impairment test by comparing the estimated future undiscounted cash flows associated with the asset to the asset's net carrying value to determine if an impairment exists. We assess impairment of property and equipment in accordance with SFAS No. 144, *Accounting for the Impairment or Disposal of Long-Lived Assets*.

Long-term debt. We state long-term debt net of any unamortized original issue premium or discount. We classify amortization of deferred financing costs and any premium or discount associated with the issuance of indebtedness as interest expense, and compute amortization by the interest method over the term of the applicable issue.

Employee benefit plans. Accounting and funding policies for our retirement plans are described in Note 11.

Income taxes. We and our qualifying subsidiaries are members of Contran's consolidated U.S federal income tax group (the "Contran Tax Group"). We and certain of our qualifying subsidiaries also file consolidated income tax returns with Contran in various U.S. state jurisdictions. As a member of the Contran Tax Group, we are jointly and severally liable for the federal income tax liability of Contran and the other companies included in the Contran Tax Group for all periods in which we are included in the Contran Tax Group. See Note 17. Contran's policy for intercompany allocation of income taxes provides that subsidiaries included in the Contran Tax Group compute their provision for income taxes on a separate company basis. Generally, subsidiaries make payments to or receive payments from Contran in the amounts they would have paid to or received from the Internal Revenue Service or the applicable state tax authority had they not been members of the Contran Tax Group. The separate company provisions and payments are computed using the tax elections made by Contran. We made net cash payments to Contran of \$1.2 million in 2006, \$5.8 million in 2007 and \$4.6 million in 2008.

We recognize deferred income tax assets and liabilities for the expected future tax consequences of temporary differences between amounts recorded in the Consolidated Financial Statements and the tax basis of our assets and liabilities, including investments in our subsidiaries and affiliates who are not members of the Contran Tax Group and undistributed earnings of foreign subsidiaries which are not permanently reinvested. In addition, we recognize deferred income taxes with respect to the excess of the financial reporting carrying amount over the income tax basis of our direct investment in Kronos common stock because the exemption under GAAP to avoid recognition of such deferred income taxes is not available to us. The earnings of our foreign subsidiaries subject to permanent reinvestment plans aggregated \$706 million at December 31, 2008 (in 2007 the amount was \$723 million). It is not practical for us to determine the amount of the unrecognized deferred income tax liability related to these earnings due to the complexities associated with the U.S. taxation on earnings of foreign subsidiaries repatriated to the U.S. We periodically evaluate our deferred tax assets in the various taxing jurisdictions in which we operate and adjust any related valuation allowance based on the estimate of the amount of such deferred tax assets we believe does not meet the more-likely-than-not recognition criteria.

Prior to 2007, we provided a reserve for uncertain income tax positions when we believed the benefit associated with a tax position was not probable of prevailing with the applicable tax authority and the amount of the lost benefit was reasonably estimable. Beginning in 2007, we record a reserve for uncertain tax positions in accordance with *Financial Accounting Standards Board Interpretation No. 48 ("FIN")*, *Accounting for Uncertain Tax Positions* for tax positions where we believe it is more-likely-than-not our position will not prevail with the applicable tax authorities. See Note 18.

NL, Kronos, CompX, Tremont and WCS are members of the Contran Tax Group. NL, Kronos and CompX are each a party to a tax sharing agreement with us and Contran pursuant to which they generally compute their provision for income taxes on a separate-company basis, and make payments to or receive payments from us in amounts that they would have paid to or received from the U.S. Internal Revenue Service or the applicable state tax authority had they not been a member of the Contran Tax Group.

Environmental remediation costs. We record liabilities related to environmental remediation obligations when estimated future expenditures are probable and reasonably estimable. We adjust our accruals as further information becomes available to us or as circumstances change. We generally do not discount estimated future expenditures to their present value due to the uncertainty of the timing of the ultimate payout. We recognize any recoveries of remediation costs from other parties when we deem their receipt to be probable. At December 31, 2007 and 2008, we had not recognized any receivables for recoveries.

Net sales. We record sales when products are shipped and title and other risks and rewards of ownership have passed to the customer, or when we perform services. We include amounts charged to customers for shipping and handling costs in net sales. We state sales net of price, early payment and distributor discounts and volume rebates. We report taxes assessed by a governmental authority such as sales, use, value added and excise taxes on a net basis.

Selling, general and administrative expenses; shipping and handling costs; advertising costs; research and development costs. Selling, general and administrative expenses include costs related to marketing, sales, distribution, shipping and handling, research and development, legal, environmental remediation and administrative functions such as accounting, treasury and finance, and includes costs for salaries and benefits, travel and entertainment, promotional materials and professional fees. Shipping and

handling costs of our Chemicals Segment were approximately \$81 million in 2006, \$82 million in 2007 and \$91 million in 2008. Shipping and handling costs of our Component Products and Waste Management Segments are not material. We expense advertising and research, development and sales technical support costs as incurred. Advertising costs were approximately \$2 million in each of 2006, 2007 and 2008. Research, development and certain sales technical support costs were approximately \$11 million in 2006, \$12 million in 2007 and \$12 million in 2008.

Note 2 - Business and geographic segments:

<u>Business segment</u>	<u>Entity</u>	<u>% owned at December 31, 2008</u>
Chemicals	Kronos	95%
Component products	CompX	87%
Waste management	WCS	100%

Our ownership of Kronos includes 59% we hold directly and 36% held directly by NL. We own 83% of NL. Our ownership of CompX is through NL. See Note 3.

Prior to March 26, 2007, we owned 35% of TIMET directly and through a wholly-owned subsidiary. On March 26, 2007, we completed a special dividend of the TIMET stock we owned. As a result, we now own approximately 1% of the TIMET shares outstanding. We accounted for our ownership of TIMET by the equity method through the date of the special dividend. See Note 3. At December 31, 2008, TIMET owned an additional 1% of us, .5% of NL and less than .1% of Kronos; see Note 13. Because we do not consolidate TIMET, our shares and the shares of NL and Kronos held by TIMET are not considered as owned by us for financial reporting purposes.

We are organized based upon our operating subsidiaries. Our operating segments are defined as components of our consolidated operations about which separate financial information is available that is regularly evaluated by our chief operating decision maker in determining how to allocate resources and in assessing performance. Each operating segment is separately managed, and each operating segment represents a strategic business unit offering different products.

We have the following three consolidated reportable operating segments.

- *Chemicals* - Our Chemicals Segment is operated through our majority ownership of Kronos. Kronos is a leading global producer and marketer of value-added titanium dioxide pigments ("TiO₂"). TiO₂ is used for a variety of manufacturing applications, including plastics, paints, paper and other industrial products. Kronos has production facilities located in North America and Europe. Kronos also owns a one-half interest in a TiO₂ production facility located in Louisiana. See Note 7.
- *Component Products* - We operate in the component products industry through our majority ownership of CompX. CompX is a leading manufacturer of security products, precision ball bearing slides and ergonomic computer support systems used in the office furniture, transportation, postal tool storage appliance and a variety of other industries. CompX is also a leading manufacturer of stainless steel exhaust systems, gauges and throttle controls for the performance marine industry.

- *Waste Management* - WCS is our wholly-owned subsidiary which owns and operates a West Texas facility for the processing, treatment, storage and disposal of hazardous, toxic and certain types of low-level radioactive waste. WCS obtained a byproduct disposal license in 2008 and is in the process constructing the byproduct disposal facility which is expected to be operational in the second half of 2009. In January 2009 WCS received a low-level radioactive waste disposal permit. Construction of the low-level radioactive waste facility is currently expected to begin in the second quarter of 2009, following the completion of some pre-construction licensing and administrative matters, and is expected to be operational in the second quarter of 2010.

We evaluate segment performance based on segment operating income, which we define as income before income taxes and interest expense, exclusive of certain non-recurring items (such as gains or losses on disposition of business units and other long-lived assets outside the ordinary course of business and certain legal settlements) and certain general corporate income and expense items (including securities transactions gains and losses and interest and dividend income), which are not attributable to the operations of the reportable operating segments. The accounting policies of our reportable operating segments are the same as those described in Note 1. Segment results we report may differ from amounts separately reported by our various subsidiaries and affiliates due to purchase accounting adjustments and related amortization or differences in how we define operating income. Intersegment sales are not material.

Interest income included in the calculation of segment operating income is not material in 2006, 2007 or 2008. Capital expenditures include additions to property and equipment but exclude amounts we paid for business units acquired in business combinations. See Note 3. Depreciation and amortization related to each reportable operating segment includes amortization of any intangible assets attributable to the segment. Amortization of deferred financing costs and any premium or discount associated with the issuance of indebtedness is included in interest expense.

Segment assets are comprised of all assets attributable to each reportable operating segment, including goodwill and other intangible assets. Our investment in the TiO₂ manufacturing joint venture (see Note 7) is included in the Chemicals Segment assets. Corporate assets are not attributable to any operating segment and consist principally of cash and cash equivalents, restricted cash equivalents, marketable securities and loans to third parties. At December 31, 2008, approximately 26% of corporate assets were held by NL (in 2007 the percentage was 24%), with substantially all of the remainder held directly by Valhi.

	<u>Years ended December 31,</u>		
	<u>2006</u>	<u>2007</u>	<u>2008</u>
	(In millions)		
Net sales:			
Chemicals	\$1,279.5	\$1,310.3	\$1,316.9
Component products	190.1	177.7	165.5
Waste management	11.8	4.2	2.9
Total net sales	<u>\$1,481.4</u>	<u>\$1,492.2</u>	<u>\$1,485.3</u>
Cost of goods sold:			
Chemicals	\$ 980.8	\$1,062.2	\$1,098.7
Component products	143.6	132.4	125.7
Waste management	15.0	11.7	14.7
Total cost of goods sold	<u>\$1,139.4</u>	<u>\$1,206.3</u>	<u>\$1,239.1</u>
Gross margin:			
Chemicals	\$ 298.7	\$ 248.1	\$ 218.2
Component products	46.5	45.3	39.8
Waste management	(3.2)	(7.5)	(11.8)
Total gross margin	<u>\$ 342.0</u>	<u>\$ 285.9</u>	<u>\$ 246.2</u>
Operating income (loss):			
Chemicals	\$ 138.1	\$ 88.6	\$ 52.0
Component products	20.6	16.0	5.5
Waste management	(9.5)	(14.1)	(21.5)
Total operating income	149.2	90.5	36.0
Equity in earnings of:			
TIMET	101.1	26.9	-
Other	3.8	1.7	(1.0)
General corporate items:			
Securities earnings	42.3	30.8	30.7
Gain on litigation settlement	-	-	47.9
Gain on disposal of fixed assets	36.4	-	-
Insurance recoveries	7.6	6.1	9.6
General expenses, net	(33.0)	(37.6)	(32.9)
Loss on prepayment of debt	(22.3)	-	-
Interest expense	(67.6)	(64.4)	(68.7)
Income before income taxes	<u>\$ 217.5</u>	<u>\$ 54.0</u>	<u>\$ 21.6</u>

	<u>Years ended December 31,</u>		
	<u>2006</u>	<u>2007</u>	<u>2008</u>
	(In millions)		
Depreciation and amortization:			
Chemicals	\$ 57.4	\$ 52.5	\$ 53.9
Component products	11.8	11.0	9.2
Waste management	2.7	2.3	2.7
Corporate	<u>.6</u>	<u>.5</u>	<u>.3</u>
Total	<u>\$ 72.5</u>	<u>\$ 66.3</u>	<u>\$ 66.1</u>
Capital expenditures:			
Chemicals	\$ 50.9	\$ 47.4	\$ 68.2
Component products	12.1	13.8	6.8
Waste management	.5	2.4	9.4
Corporate	<u>.3</u>	<u>.2</u>	<u>.5</u>
Total	<u>\$ 63.8</u>	<u>\$ 63.8</u>	<u>\$ 84.9</u>

	<u>December 31,</u>		
	<u>2006</u>	<u>2007</u>	<u>2008</u>
	(In millions)		
Total assets:			
Operating segments:			
Chemicals	\$1,826.8	\$1,862.6	\$1,760.2
Component products	169.2	185.4	163.9
Waste management	53.4	59.7	85.8
Investments accounted for by the Equity method:			
TIMET common stock	264.1	-	-
Other - joint ventures	18.8	19.4	18.4
Corporate and eliminations	<u>472.4</u>	<u>475.9</u>	<u>361.1</u>
Total	<u>\$2,804.7</u>	<u>\$2,603.0</u>	<u>\$2,389.4</u>

Geographic information. We attribute net sales to the place of manufacture (point-of-origin) and the location of the customer (point-of-destination); we attribute property and equipment to their physical location. At December 31, 2008 the net assets of our non-U.S. subsidiaries included in consolidated net assets approximated \$550 million (in 2007 the total was \$624 million).

	<u>Years ended December 31,</u>		
	<u>2006</u>	<u>2007</u>	<u>2008</u>
	(In millions)		
Net sales - point of origin:			
United States	\$ 667.1	\$ 638.4	\$ 617.2
Germany	672.0	700.6	694.8
Canada	265.2	260.7	243.8
Belgium	192.9	209.8	207.7
Norway	173.5	184.3	194.2
Taiwan	15.9	11.7	8.3
Eliminations	<u>(505.2)</u>	<u>(513.3)</u>	<u>(480.7)</u>
Total	<u>\$1,481.4</u>	<u>\$1,492.2</u>	<u>\$1,485.3</u>
Net sales - point of destination:			
North America	\$ 609.9	\$ 545.8	\$ 530.2
Europe	732.9	811.8	814.6
Asia and other	<u>138.6</u>	<u>134.6</u>	<u>140.5</u>
Total	<u>\$1,481.4</u>	<u>\$1,492.2</u>	<u>\$1,485.3</u>

	<u>December 31,</u>		
	<u>2006</u>	<u>2007</u>	<u>2008</u>
	(In millions)		
Net property and equipment:			
United States	\$ 78.2	\$ 82.3	\$ 97.0
Germany	301.4	332.1	310.7
Canada	80.6	89.6	69.7
Norway	76.2	95.8	88.5
Belgium	67.2	74.1	68.0
Taiwan	<u>7.7</u>	<u>7.4</u>	<u>7.1</u>
Total	<u>\$ 611.3</u>	<u>\$681.3</u>	<u>\$641.0</u>

Note 3 - Business combinations and related transactions:

Kronos Worldwide, Inc. During 2006, we purchased an aggregate of .9 million shares of Kronos common stock in market transactions for \$25.4 million. During 2008 NL purchased 79,503 Kronos shares in market transactions for \$.8 million.

TIMET. At the beginning of 2006, we owned an aggregate of 39% of TIMET's outstanding common stock either directly and through a wholly-owned subsidiary. Our ownership of TIMET was reduced to 35% by December 31, 2006 due to stock option exercises by TIMET employees and the conversion of shares of TIMET's convertible preferred stock into TIMET common stock, offset in part by our purchase of an aggregate of 607,000 shares of TIMET common stock (as adjusted for certain TIMET stock splits) in market transactions during 2006 for an aggregate of \$18.7 million.

On March 26, 2007, we completed a special dividend of the TIMET common stock we owned to our stockholders. Each of our stockholders received .4776 of a share of TIMET common stock for each share of our common stock held. For financial reporting purposes, we continued to apply the equity method to our investment in TIMET through March 31, 2007. As a result of the distribution, we now own approximately 1% of the TIMET shares outstanding. We accounted for our dividend of TIMET common stock as a spin-off in which we reduced our stockholders' equity by the aggregate book value of the shares distributed, net of applicable tax, or approximately \$897.4 million. For income tax purposes, the dividend of TIMET common stock was taxable to us based on the difference between the aggregate fair value of the TIMET shares distributed (\$36.90 per share, or an aggregate of \$2.1 billion) and our tax basis of the shares distributed. This tax obligation was approximately \$667.7 million, after we utilized available net operating loss ("NOL") carryforwards of \$57.8 million and alternative minimum tax credit ("AMT") carryforwards of \$1.1 million.

We and our qualifying subsidiaries are members of Contran's consolidated U.S. federal income tax group (the "Contran Tax Group"), and we make payments to Contran for income taxes in amounts that we would have paid to the U.S. Internal Revenue Service had we not been a member of the Contran Tax Group. As a member of the Contran Tax Group, the tax obligation generated from the special dividend is payable to Contran. In order to discharge substantially all of this tax obligation we owed to Contran, in March 2007 we issued to Contran shares of a new issue of our preferred stock. See Note 14. Because Contran directly or indirectly owned approximately 92% of our common stock at March 26, 2007, we distributed a substantial portion of the TIMET shares to other members of the Contran Tax Group. As a result, Contran was not currently required to pay this tax obligation to the applicable tax authority (approximately \$620 million at December 31, 2007), because the gain on the shares distributed to members of Contran's Tax Group is currently deferred at the Contran level. This income tax liability would become payable by Contran to the applicable tax authority when the shares of TIMET common stock we distributed to other members of the Contran Tax Group are sold or otherwise transferred outside the Contran Tax Group or in the event of certain restructuring transactions involving Contran and us.

NL owned approximately 4.7 million shares of our common stock at the time of the distribution, and for financial reporting purposes we account for our proportional interest in such shares as treasury stock. See Note 14. Under Delaware Corporation Law, NL receives dividends on its Valhi shares. As a result, NL received approximately 2.2 million shares of the TIMET common stock we distributed in the special dividend. In addition, in March 2007 we purchased shares of our common stock in market transactions under our repurchase program described in Note 14. Because we purchased these shares between the record date and payment date of the special dividend, we became entitled to receive the shares of TIMET common stock we distributed in the special dividend with respect to the shares of our common stock we repurchased, or approximately 19,000 shares of TIMET common stock. We allocated the cost of our shares we repurchased between the TIMET and Valhi common stock acquired based upon relative market values on the date of purchase, and we allocated an aggregate of \$.7 million to the TIMET shares we acquired. At the end of the first quarter of 2007, the aggregate number of TIMET shares we owned represented approximately 1% of TIMET's outstanding common stock. Accordingly, effective March 31, 2007 we began accounting for our shares of TIMET common stock as available-for-sale marketable securities carried at fair value, and the difference between the aggregate fair value and the cost basis of our TIMET shares is recognized as a component of accumulated other comprehensive income, net of applicable income tax and minority interest. The cost basis of the TIMET shares NL received was \$11.4 million, which represents our basis in such TIMET shares under the equity method immediately before the special dividend. During the fourth quarter of 2007, NL sold .8 million shares of its TIMET common stock to us for a cash price of

\$33.50 per share, or an aggregate of \$26.8 million. For financial reporting purposes, NL's previous \$4 million aggregate cost basis of these .8 million shares is also our cost basis in these shares. A substantial portion of the increase in our accumulated other comprehensive income related to marketable securities during 2007 relates to the unrealized gain, net of applicable income tax and minority interest, related to these shares of TIMET common stock.

For income tax purposes, the tax basis in the shares of TIMET received by NL in the special dividend is equal to the fair value of such TIMET shares on the date of the special dividend. However, because the fair value of all of the TIMET shares we distributed exceeded our cumulative earnings and profits as of the end of 2007, NL was required to reduce the tax basis of its shares of Valhi common stock by an amount equal to the lesser of (i) its tax basis in such Valhi shares and (ii) its pro-rata share of the amount by which the aggregate fair value of the TIMET shares we distributed exceeded our earnings and profits. Additionally, since NL's pro-rata share of the amount by which the aggregate fair value of the TIMET shares we distributed exceeded our 2007 earnings and profits was greater than the tax basis of its Valhi shares, NL was required to recognize a capital gain for the difference. The benefit to NL associated with receiving a fair-value tax basis in its TIMET shares was completely offset by the elimination of the tax basis in its Valhi shares and the capital gain NL is required to recognize for the excess. NL's income tax generated from this capital gain was approximately \$11.2 million. For financial reporting purposes, NL provided deferred income taxes for the excess of the carrying value over the tax basis of its shares of both Valhi and TIMET common stock, and as a result the \$11.2 million current income tax generated by NL was offset by deferred income taxes NL had previously provided on its shares of Valhi common stock. However, because we account for our proportional interest in the Valhi shares held by NL as treasury stock, we also eliminated our proportional interest in the deferred income taxes NL recognized at its level with respect to the Valhi shares it holds. As a result, for financial reporting purposes we had not previously recognized our proportional interest in the \$11.2 million of income taxes (or \$9.3 million) that NL had previously recognized. Accordingly, as part of the special dividend we were required to recognize \$9.3 million of income taxes related to the income tax effect to NL of the special dividend in 2007.

NL is also a member of the Contran Tax Group, and NL makes payments to us for income taxes in amounts it would have paid to the U.S. Internal Revenue Service had NL not been a member of the Contran Tax Group. Approximately \$10.8 million of the \$11.2 million tax generated by NL was payable to us (the remaining \$.4 million relates to one of NL's subsidiaries that was not a member of the Contran Tax Group). We are not currently required to pay this \$10.8 million tax liability to Contran, nor is Contran currently required to pay this tax liability to the applicable tax authority, because the related taxable gain is currently deferred at our level and the Contran level since we and NL are members of the Valhi tax group on a separate company basis and of the Contran Tax Group on the distribution date. This income tax liability would become payable by us to Contran, and by Contran to the applicable tax authority, when the shares of Valhi common stock held by NL are sold or otherwise transferred outside the Contran Tax Group or in the event of certain restructuring transactions involving NL and Valhi. At December 31, 2008, this \$10.8 million is recognized as a component of our deferred income taxes.

A summary of the \$897.4 million net reduction in our stockholders' equity as a result of the special dividend is summarized as follows:

	<u>Amount</u>
	<u>(In millions)</u>
Investment in TIMET	\$276.7
Deferred income taxes previously recognized:	
Investment in TIMET	(56.9)
NOL and AMT carryforwards	21.4
Income taxes generated from the special dividend:	
Valhi level, net of amount included in other comprehensive income	646.9
NL level	<u>9.3</u>
Total	<u>\$897.4</u>

CompX International Inc. During 2006, NL purchased an aggregate of 147,500 shares of CompX common stock in market transactions for approximately \$2.3 million.

In August 2007, CompX's board of directors authorized the repurchase of up to 500,000 shares of its Class A common stock in open market transactions, including block purchases, or in privately-negotiated transactions at unspecified prices and over an unspecified period of time. This authorization was in addition to the 467,000 shares of Class A common stock that remained available for repurchase under prior authorizations of CompX's board of directors. CompX may repurchase its common stock from time to time as market conditions permit. The stock repurchase program does not include specific price targets or timetables and may be suspended at any time. Depending on market conditions, CompX may terminate the program prior to its completion. CompX will use cash on hand to acquire the shares. Repurchased shares will be added to CompX's treasury and cancelled. During 2007, CompX purchased 179,100 shares of its Class A common stock in market transactions for an aggregate of \$3.3 million and during 2008 CompX purchased 126,000 shares of its Class A common stock in market transactions for an aggregate of \$1.0 million. At December 31, 2008 approximately 678,000 shares were available for purchase under these repurchase authorizations.

In October 2007, the independent members of CompX's board of directors authorized the repurchase or cancellation of a net 2.7 million shares of its Class A common stock held by TIMET, including the Class A shares held indirectly by TIMET through its ownership interest in CompX Group. These repurchases or cancellations were made outside of CompX's stock repurchase plan discussed above. CompX purchased these shares for \$19.50 per share, or aggregate consideration of \$52.6 million, which it paid in the form of a promissory note. The price per share was determined based on CompX's open market repurchases of its Class A common stock around the time the repurchase or cancellation was approved. The promissory note bears interest at LIBOR plus 1% and provides for quarterly principal repayments of \$250,000 commencing in September 2008, with the balance due at maturity in September 2014. CompX may make prepayments on the promissory note at any time, in any amount, without penalty. The promissory note is subordinated to CompX's U.S. revolving bank credit agreement. See Notes 9 and 16.

As a result of CompX's repurchase and/or cancellation of its Class A shares owned directly or indirectly by TIMET, TIMET no longer has any direct or indirect ownership in CompX or CompX Group, CompX's outstanding Class A shares were reduced by 2.7 million shares and our ownership interest in CompX increased to 87%.

Note 4 - Marketable securities:

	<u>December 31,</u>	
	<u>2007</u>	<u>2008</u>
	(In millions)	
Current assets:		
Restricted debt securities	\$ 5.9	\$ 5.5
Other debt securities	<u>1.3</u>	<u>3.3</u>
Total	<u>\$ 7.2</u>	<u>\$ 8.8</u>
Noncurrent assets:		
The Amalgamated Sugar Company LLC	\$250.0	\$250.0
TIMET	60.2	20.1
Restricted debt securities	3.2	3.5
Other debt securities and common stocks	<u>6.4</u>	<u>1.9</u>
Total	<u>\$319.8</u>	<u>\$275.5</u>

Fair Value Measurements at December 31, 2008

	<u>Total</u>	<u>Quoted Prices in Active Markets (Level 1)</u>	<u>Significant Other Observable Inputs (Level 2)</u>	<u>Significant Unobservable Inputs (Level 3)</u>
	(In millions)			
Current assets:				
Restricted debt securities	\$ 5.5	\$ -	\$ 5.5	\$ -
Other debt securities	<u>3.3</u>	<u>-</u>	<u>3.3</u>	<u>-</u>
Total	<u>\$ 8.8</u>	<u>\$ -</u>	<u>\$ 8.8</u>	<u>\$ -</u>
Noncurrent assets:				
The Amalgamated Sugar Company LLC	\$250.0	\$ -	\$ -	\$250.0
TIMET	20.1	20.1	-	-
Other debt securities and common stocks	<u>5.4</u>	<u>5.0</u>	<u>.4</u>	<u>-</u>
Total	<u>\$275.5</u>	<u>\$ 25.1</u>	<u>\$.4</u>	<u>\$250.0</u>

Amalgamated Sugar. Prior to 2006, we transferred control of the refined sugar operations previously conducted by our wholly-owned subsidiary, The Amalgamated Sugar Company, to Snake River Sugar Company, an Oregon agricultural cooperative formed by certain sugarbeet growers in Amalgamated's areas of operations. Pursuant to the transaction, we contributed substantially all of the net assets of our refined sugar operations to The Amalgamated Sugar Company LLC, a limited liability company controlled by Snake River, on a tax-deferred basis in exchange for a non-voting ownership interest in the LLC. The cost basis of the net assets we transferred to the LLC was approximately \$34 million. When we transferred control of our operations to Snake River in return for our interest in the LLC, we recognized a gain in earnings equal to the difference between \$250 million (the fair value of our investment in the LLC as evidenced by its \$250 million redemption price, as discussed below) and the \$34 million cost basis of the net assets we contributed to the LLC, net of applicable deferred income taxes. Therefore, the cost basis of our investment in the LLC is \$250 million. As part of this transaction, Snake River made certain loans to us aggregating \$250 million. These loans are collateralized by our interest in the LLC. See Notes 9 and 15.

We and Snake River share in distributions from the LLC up to an aggregate of \$26.7 million per year (the "base" level), with a preferential 95% share going to us. To the extent the LLC's distributions are below this base level in any given year, we are entitled to an additional 95% preferential share of any future annual LLC distributions in excess of the base level until the shortfall is recovered. Under certain conditions, we are entitled to receive additional cash distributions from the LLC. At our option, we may require the LLC to redeem our interest in the LLC beginning in 2012, and the LLC has the right to redeem, at their option, our interest in the LLC beginning in 2027. The redemption price is generally \$250 million plus the amount of certain undistributed income allocable to us. If we require the LLC to redeem our interest in the LLC, Snake River has the right to accelerate the maturity of and call our \$250 million loans from Snake River. See Note 9.

The LLC Company Agreement contains certain restrictive covenants intended to protect our interest in the LLC, including limitations on capital expenditures and additional indebtedness of the LLC. We also have the ability to temporarily take control of the LLC if our cumulative distributions from the LLC fall below specified levels, subject to satisfaction of certain conditions imposed by Snake River's current third-party senior lenders.

Prior to 2006, Snake River agreed that the annual amount of distributions we receive from the LLC would exceed the annual amount of interest payments we owe to Snake River on our \$250 million in loans from Snake River by at least \$1.8 million. If we receive less than the required minimum amount, certain agreements we previously made with Snake River and the LLC, including a reduction in the amount of cumulative distributions that we must receive from the LLC in order to prevent us from becoming able to temporarily take control of the LLC, would retroactively become null and void and we would be able to temporarily take control of the LLC if we so desired. Through December 31, 2008, Snake River and the LLC maintained the applicable minimum required levels of cash flows to us.

We report the cash distributions received from the LLC as dividend income. We recognize distributions when they are declared by the LLC, which is generally the same month we receive them, although in certain cases distributions may be paid on the first business day of the following month. See Note 15. The amount of such future distributions we will receive from the LLC is dependent upon, among other things, the future performance of the LLC's operations. Because we receive preferential distributions from the LLC and we have the right to require the LLC to redeem our interest for a fixed and determinable amount beginning at a fixed and determinable date, we account for our investment in the LLC as a marketable security carried at its cost basis of \$250 million. The cost basis is also the fair value of our investment determined using Level 3 inputs as defined in SFAS No. 157 as the \$250 million redemption price of our investment in the LLC as well as the amount of our debt owed to Snake River Company. There has been no change to the fair value of our Amalgamated Sugar investment during 2008. We also provide certain services to the LLC, as discussed in Note 16. We do not expect to report a gain on the redemption at the time our LLC interest is redeemed, as the redemption price of \$250 million is expected to equal the carrying value of our investment in the LLC at the time of redemption.

TIMET. See Note 3 for information on our investment in TIMET (which we have classified as available-for-sale). The fair value is determined using Level 1 inputs as defined in SFAS No. 157 as TIMET common stock is actively traded on the NYSE.

Other. The aggregate cost of the restricted and unrestricted debt securities and other marketable securities (which we have classified as available-for-sale) approximates their net carrying value at December 31, 2007 and 2008. The fair value of these securities is generally determined using Level 2 inputs as defined in SFAS No. 157 because although these securities are traded in many cases the market is not active and the year-end valuation is generally based on the last trade of the year, which may be several days prior to December 31. During 2007 and 2008, we purchased other marketable securities (primarily common stocks and debt securities) for an aggregate of \$23.3 million and \$6.1 million, respectively, and subsequently sold a portion of such securities for an aggregate of \$28.5 million and \$7.9 million, respectively, which generated a net securities transaction loss of \$.1 million in 2007 and \$1.2 million in 2008. See Note 15.

Note 5 - Accounts and other receivables, net:

	<u>December 31,</u>	
	<u>2007</u>	<u>2008</u>
	(In millions)	
Accounts receivable	\$239.2	\$194.9
Accrued insurance recoveries - NL (see Note 15)	-	7.2
Notes receivable	4.5	4.0
Accrued interest and dividends receivable	.1	.1
Allowance for doubtful accounts	<u>(2.4)</u>	<u>(2.7)</u>
Total	<u>\$241.4</u>	<u>\$203.5</u>

Note 6 - Inventories, net:

	<u>December 31,</u>	
	<u>2007</u>	<u>2008</u>
	(In millions)	
Raw materials:		
Chemicals	\$ 66.2	\$ 67.1
Component products	<u>6.3</u>	<u>7.5</u>
Total raw materials	<u>72.5</u>	<u>74.6</u>
Work in process:		
Chemicals	19.9	19.8
Component products	<u>9.8</u>	<u>8.2</u>
Total in-process products	<u>29.7</u>	<u>28.0</u>
Finished products:		
Chemicals	171.6	243.8
Component products	<u>8.2</u>	<u>6.9</u>
Total finished products	<u>179.8</u>	<u>250.7</u>
Supplies (primarily chemicals)	<u>55.9</u>	<u>55.2</u>
Total	<u>\$337.9</u>	<u>\$408.5</u>

Note 7 - Other assets:

	<u>December 31,</u>	
	<u>2007</u>	<u>2008</u>
	(In millions)	
Investment in affiliates:		
TiO ₂ manufacturing joint venture	\$118.5	\$105.6
Basic Management and Landwell	<u>19.4</u>	<u>18.4</u>
Total	<u>\$137.9</u>	<u>\$124.0</u>
Other assets:		
Waste disposal site operating permits, net	\$ 29.8	\$ 43.7
Deferred financing costs	8.2	7.1
IBNR receivables	7.8	7.5
Loans and other receivables	1.8	15.6
Other	<u>19.7</u>	<u>13.4</u>
Total	<u>\$ 67.3</u>	<u>\$ 87.3</u>

Investment in TiO₂ manufacturing joint venture. Our Chemicals Segment and another TiO₂ producer, Tioxide Americas, Inc. ("Tioxide"), are equal owners of a manufacturing joint venture (Louisiana Pigment Company, L.P., or "LPC") that owns and operates a TiO₂ plant in Louisiana. Tioxide is a wholly-owned subsidiary of Huntsman Corporation.

We and Tioxide are both required to purchase one-half of the TiO₂ produced by LPC. LPC operates on a break-even basis and, accordingly, we report no equity in earnings of LPC. Each owner's acquisition transfer price for its share of the TiO₂ produced is equal to its share of the joint venture's production costs and interest expense, if any. Our share of net cost is reported as cost of sales as the related TiO₂ acquired from LPC is sold. We include the distributions from LPC, which generally relate to excess cash from non-cash production costs, and contributions to LPC, which generally relate to cash required by LPC when it builds working capital, in cash flows from operating activities in our Consolidated Statements of Cash Flows. We report distributions or contributions net of any contributions or distributions we made during the periods they occur. Our net distributions of \$2.3 million in 2006 are stated net of contributions of \$11.9 million in 2006. Contributions of \$4.9 million in 2007 are stated net of distributions of \$8.0 million in 2007. Our net distributions of \$10.0 million in 2008 are stated net of contributions of \$10.6 million in 2008.

Certain selected financial information of LPC is summarized below:

	<u>December 31,</u>	
	<u>2007</u>	<u>2008</u>
	(In millions)	
Current assets	\$ 68.3	\$ 68.9
Property and equipment, net	<u>195.2</u>	<u>181.7</u>
Total assets	<u>\$263.5</u>	<u>\$250.6</u>
Liabilities, primarily current	\$ 23.8	\$ 36.7
Partners' equity	<u>239.7</u>	<u>213.9</u>
Total liabilities and partners' equity	<u>\$263.5</u>	<u>\$250.6</u>

	<u>Years ended December 31,</u>		
	<u>2006</u>	<u>2007</u>	<u>2008</u>
	(In millions)		
Net sales:			
Kronos	\$124.2	\$124.6	\$140.3
Tioxide	125.2	125.0	140.7
Cost of sales	249.3	249.6	280.5
Net income	-	-	-

On September 22, 2005, LPC's facility temporarily halted production due to Hurricane Rita. Although storm damage to core processing facilities was not extensive, a variety of factors, including loss of utilities, limited access and availability of employees and raw materials, prevented the resumption of partial operations until October 9, 2005 and full operations until late 2005. The majority of LPC's property damage and unabsorbed fixed costs, for periods in which normal production levels were not achieved, were covered by insurance, and insurance covered our lost profits (subject to applicable deductibles) resulting from our share of the lost production at LPC. Both we and LPC filed claims with our insurers. We recognized income of \$1.8 million related to our business interruption claim in the fourth quarter of 2006, which is included in other income on our Consolidated Statement of Operations.

Investment in Basic Management and Landwell. We also own a 32% interest in Basic Management, Inc., which, provides utility services in the industrial park where one of TIMET's plants is located, among other things. We also have 12% interest in The Landwell Company, which is actively engaged in efforts to develop certain real estate. Basic Management owns an additional 50% interest in Landwell. For federal income tax purposes Landwell is treated as a partnership, and accordingly the combined results of operations of Basic Management and Landwell include a provision for income taxes on Landwell's earnings only to the extent that such earnings accrue to Basic Management. We record our equity in earnings of Basic Management and Landwell on a one-quarter lag because their financial statements are generally not available to us on a timely basis. Certain selected combined financial information of Basic Management and Landwell is summarized below.

	<u>September 30,</u>	
	<u>2007</u>	<u>2008</u>
	(In millions)	
Current assets	\$ 39.6	\$ 31.3
Property and equipment, net	11.1	10.4
Prepaid costs and other	4.7	4.4
Land and development costs	15.4	15.4
Notes and other receivables	1.6	.4
Investment in undeveloped land and water rights	<u>45.7</u>	<u>50.8</u>
Total assets	<u>\$118.1</u>	<u>\$112.7</u>
Current liabilities	\$ 15.2	\$ 15.0
Long-term debt	18.2	19.8
Deferred income taxes	6.5	6.3
Other noncurrent liabilities	1.3	1.3
Equity	<u>76.9</u>	<u>70.3</u>
Total liabilities and equity	<u>\$118.1</u>	<u>\$112.7</u>

Twelve months ended September 30,

	<u>2006</u>	<u>2007</u>	<u>2008</u>
	(In millions)		
Total revenues	\$31.4	\$23.5	\$ 9.0
Income (loss) before income taxes	16.6	10.2	(4.7)
Net income (loss)	13.5	9.0	(3.9)

Other. We have certain related party transactions with some of these affiliates, as more fully described in Note 16.

The IBNR receivables relate to certain insurance liabilities, the risk of which we have reinsured with certain third party insurance carriers. We report the insurance liabilities related to these IBNR receivables which have been reinsured as part of noncurrent accrued insurance claims and expenses. Certain of our insurance liabilities are classified as current liabilities and the related IBNR receivables are classified with prepaid expenses and other current assets. See Notes 10 and 16. At December 31, 2008, \$15.0 million of our loans and notes receivables relate to a promissory note held by NL, as discussed in Note 17.

Note 8 - Goodwill and other intangible assets:

Goodwill. Changes in the carrying amount of goodwill during the past three years by operating segment is presented in the table below.

	<u>Operating segment</u>		<u>Total</u>
	<u>Chemicals</u>	<u>Component Products</u>	
	(In millions)		
Balance at December 31, 2005	\$341.0	\$ 20.8	\$361.8
Goodwill acquired	17.6	5.6	23.2
Changes in foreign exchange rates	-	.2	.2
Balance at December 31, 2006	358.6	26.6	385.2
Goodwill acquired	(.1)	21.7	21.6
Balance at December 31, 2007	358.5	48.3	406.8
Goodwill impairment	-	(10.1)	(10.1)
Changes in foreign exchange rates	-	(.1)	(.1)
Goodwill acquired	.5	(.3)	.2
Balance at December 31, 2008	<u>\$359.0</u>	<u>\$ 37.8</u>	<u>\$396.8</u>

Goodwill is assigned to four of our reporting units. Substantially all of our goodwill related to our Chemicals Segment was generated from our various step acquisitions of NL and Kronos. Substantially all of the goodwill related to the Component Products Segment was generated from CompX's acquisitions of certain business units and the step acquisitions of CompX discussed in Note 3. The Component Products Segment goodwill is assigned to the three reporting units within that operating segment: security products, furniture, and marine components. In accordance with SFAS No. 142 we test for goodwill impairment at the reporting unit level. We use discounted cash flows to estimate the fair value of the three Component Product Segment units. Such discounted cash flows are a Level 3 input as defined by SFAS No. 157 (although SFAS No. 157 is not in effect with respect to estimating the fair value of a reporting unit under SFAS No. 142 until January 1, 2009). In determining the estimated fair value of our Chemicals Segment, we consider the quoted market prices for Kronos' common stock.

In accordance with the requirements of SFAS No. 142, we review goodwill for each of our four reporting units for impairment during the third quarter of each year or when circumstances arise that indicate an impairment might be present. If the fair value of an evaluated asset is less than its book value, the asset is written down to fair value. Our 2006 and 2007 annual impairment reviews of goodwill indicated no impairments.

During the third quarter of 2008, our Component Products Segment determined that all of the goodwill associated with its marine components reporting unit was impaired. We recognized a \$10.1 million charge for the goodwill impairment, which represented all of the goodwill we had previously recognized for the Marine Components reporting unit of our Component Products Segment (including a nominal amount of goodwill inherent in our investment in CompX). The factors that led us to conclude goodwill associated with the Marine Components reporting unit was fully impaired include the continued decline in consumer spending in the marine market as well as the overall negative economic outlook, both of which resulted in near-term and longer-term reduced revenue, profit and cash flow forecasts for the Marine Components unit. While we continue to believe in the long-term potential of the Marine Components reporting unit, due to the extraordinary economic downturn in the boating industry we are not currently able to foresee when the industry and our business will recover. In response to the present economic conditions, we have taken steps to reduce operating costs without inhibiting our ability to take advantage of opportunities to expand our market share.

When we performed this analysis in the third quarter of 2008, we also reviewed the goodwill associated with all of our other reporting units and concluded there was no impairment of the goodwill for those reporting units. Due to the continued weakening of the economy, we re-evaluated the goodwill associated with the furniture components reporting unit within our Component Products Segment again in the fourth quarter of 2008 and concluded that no additional impairments were present.

Other intangible assets.

	<u>December 31,</u>	
	<u>2007</u>	<u>2008</u>
	(In millions)	
Definite-lived customer list intangible asset	\$.6	\$ -
Patents and other intangible assets	<u>2.1</u>	<u>2.0</u>
Total	<u>\$2.7</u>	<u>\$2.0</u>

Amortization expense was \$4.2 million, \$1.2 million and \$.7 million in 2006, 2007 and 2008, respectively. Estimated aggregate intangible asset amortization expense for the next five years is as follows:

2009	\$.6 million
2010	.6 million
2011	.4 million
2012	.3 million
2013	.1 million

Note 9 - Long-term debt:

	<u>December 31,</u>	
	<u>2007</u>	<u>2008</u>
	(In millions)	
Valhi:		
Snake River Sugar Company	\$250.0	\$250.0
Revolving bank credit facility	-	7.3
Total Valhi debt	<u>250.0</u>	<u>257.3</u>
Subsidiary debt:		
Kronos International 6.5% Senior Secured Notes	585.5	560.0
CompX promissory note payable to TIMET	50.0	43.0
Kronos European bank credit facility	-	42.2
Kronos U.S. bank credit facility	15.4	13.7
Other	<u>5.7</u>	<u>4.2</u>
Total subsidiary debt	<u>656.6</u>	<u>663.1</u>
Total debt	906.6	920.4
Less current maturities	<u>16.8</u>	<u>9.4</u>
Total long-term debt	<u>\$889.8</u>	<u>\$911.0</u>

Valhi. Our \$250 million in loans from Snake River Sugar Company are collateralized by our interest in The Amalgamated Sugar Company LLC. The loans bear interest at a weighted average fixed interest rate of 9.4% and are due in January 2027. At December 31, 2008, \$37.5 million of the loans are recourse to us and the remaining \$212.5 million is nonrecourse to us. Under certain conditions, Snake River has the ability to accelerate the maturity of these loans. See Note 4.

We have an \$85 million revolving bank credit facility which matures in October 2009, generally bears interest at LIBOR plus 1.75% (for LIBOR-based borrowings) or prime (for prime-based borrowings), the borrowing rate was 3.25% at December 31, 2008. The facility is collateralized by 20 million shares of Kronos common stock we own. The agreement limits our ability to pay dividends and incur additional indebtedness and contains other provisions customary in lending transactions of this type. In the event of a change of control, as defined in the agreement, the lenders have the right to accelerate the maturity of the facility. The maximum amount we may borrow under the facility is limited to one-third of the market value of the Kronos common stock we have pledged as collateral. Based on the December 31, 2008 closing market price of \$11.65 per share, for the Kronos common stock pledged under the facility, provided a maximum borrowing availability of \$76.8 million. At December 31, 2008, there were \$1.4 million of letters of credit outstanding under the facility. At December 31, 2008, \$68.2 million was available for future borrowings under the facility.

Kronos and its subsidiaries. In April 2006, we issued euro 400 million principal amount of 6.5% Senior Secured Notes due 2013 at 99.306% of the principal amount (\$498.5 million when issued). We collateralized the 6.5% Notes with a pledge of 65% of the common stock or other ownership interests of certain of our first-tier European operating subsidiaries: Kronos Titan GmbH, Kronos Denmark ApS, Kronos Limited and Societe Industrielle Du Titane, S.A. We issued the 6.5% Notes pursuant to an indenture which contains a number of covenants and restrictions which, among other things, restricts our ability to incur additional debt, incur liens, pay dividends or merge or consolidate with, or sell or transfer all or substantially all of Kronos' European assets to, another entity. At our option, we may redeem the 6.5% Notes on or after

October 15, 2009 at redemption prices ranging from 103.25% of the principal amount, declining to 100% on or after October 15, 2012. In addition, on or before April 15, 2009, we may redeem up to 35% of the Notes with the net proceeds of a qualified public equity offering at 106.5% of the principal amount. In the event of a change of control of KII, as defined in the agreement, we would be required to make an offer to purchase our 6.5% Notes at 101% of the principal amount. We would also be required to make an offer to purchase a specified portion of our 6.5% Notes at par value in the event KII generates a certain amount of net proceeds from the sale of assets outside the ordinary course of business, and such net proceeds are not otherwise used for specified purposes within a specified time period. The indenture also contains certain cross-referenced provisions, as discussed below. The carrying amount of the 6.5% Notes includes euro 2.1 million (\$3.1 million) and euro 1.7 million (\$2.4 million) of unamortized original issue discount at December 31, 2007 and 2008, respectively.

In May 2006, we used the net proceeds from the 6.5% Notes to redeem our existing 8.875% Senior Secured Notes at 104.437% of the aggregate principal amount of euro 375 million for an aggregate of \$491.4 million, including the \$20.9 million call premium. We recognized a \$22.3 million pre-tax interest charge in 2006 related to the prepayment of the 8.875% Notes, consisting of the call premium on the 8.875% Notes and the write-off of deferred financing costs and unamortized premium related to the notes.

Our Chemicals Segment's operating subsidiaries in Germany, Belgium, Norway and Denmark have a euro 80 million secured revolving bank credit facility that matures in May 2011. We may denominate borrowings in euros, Norwegian kroners or U.S. dollars. Outstanding borrowings bear interest at the applicable interbank market rate plus 1.75% (4.49% at December 31, 2008). We may also issue up to euro 5 million of letters of credit. The facility is collateralized by the accounts receivable and inventories of the borrowers, plus a limited pledge of all of the other assets of the Belgian borrower. This facility contains certain restrictive covenants that, among other things, restrict the ability of the borrowers to incur debt, incur liens, pay dividends or merge or consolidate with, or sell or transfer all or substantially all of the assets of the borrowers to, another entity. At December 31, 2008, we had borrowed a net euro 30.0 million and the equivalent of \$70.3 million was available for borrowings under the facility, subject to being in compliance with financial covenants or obtaining a waiver or amendment to the credit facility, as more fully described in **Restrictions and other**.

Our Chemicals Segment has a \$70 million U.S. revolving credit facility that matures in September 2011. This facility is collateralized by our U.S. accounts receivable, inventories and certain fixed assets. We are limited to borrowing the lesser of \$70 million or a formula-determined amount based upon the accounts receivable and inventories that have been pledged. Borrowings bear interest at either the prime rate (prime plus 0.25% in some cases) or rates based upon the Eurodollar rate plus a range of 2.25% to 2.75%. (3.25% at December 31, 2008). The facility contains certain restrictive covenants which, among other things, restrict the ability of the borrowers to incur debt, incur liens, pay dividends in certain circumstances, sell assets or enter into mergers. At December 31, 2008, \$29.0 million was available for borrowings under the facility.

Our Chemicals Segment also has a Cdn. \$30 million revolving credit facility that had a maturity date of January 15, 2009. Prior to maturity we and the lender temporarily extended the borrowing terms of this agreement on a month-to-month basis, and we are in the process of renegotiating this facility, and expect a new agreement in place in the first quarter 2009. The facility is collateralized by the accounts receivable and inventories of the borrower. Borrowings under this facility are limited to the lesser of Cdn. \$26 million or a formula-determined amount based upon the accounts receivable

and inventories of the borrower. Borrowings bear interest at rates based upon either the Canadian prime rate, the U.S. prime rate or LIBOR. The facility contains certain restrictive covenants which, among other things, restrict the ability of the borrower to incur debt, incur liens, pay dividends in certain circumstances, sell assets or enter into mergers. At December 31, 2008, no amounts were outstanding and the equivalent of \$12.9 million was available for borrowing under the facility.

Under the cross-default provisions of the 6.5% Notes, the 6.5% Notes may be accelerated prior to their stated maturity if Kronos' European subsidiaries default under any other indebtedness in excess of \$20 million due to a failure to pay the other indebtedness at its due date (including any due date that arises prior to the stated maturity as a result of a default under the other indebtedness). Under the cross-default provisions of the European revolving credit facility, any outstanding borrowings under the facility may be accelerated prior to their stated maturity if the borrowers or their parent company default under any other indebtedness in excess of euro 5 million due to a failure to pay the other indebtedness at its due date (including any due date that arises prior to the stated maturity as a result of a default under the other indebtedness). Under the cross-default provisions of the U.S. revolving credit facility, any outstanding borrowing under the facility may be accelerated prior to their stated maturity in the event of the bankruptcy of Kronos. The Canadian revolving credit facility contains no cross-default provisions. The European, U.S. and Canadian revolving credit facilities each contain provisions that allow the lender to accelerate the maturity of the applicable facility in the event of a change of control, as defined in the respective agreement, of the applicable borrower. In the event any of these cross-default or change-of-control provisions become applicable, and the indebtedness is accelerated, we would be required to repay the indebtedness prior to their stated maturity.

CompX. At December 31, 2008, our Component Products Segment had a \$50 million revolving bank credit facility that matured in January 2009. At December 31, 2008, we had no outstanding draws against the credit facility and the full \$50 million was available for borrowing. In January 2009, we amended the terms of the credit facility to extend the maturity date to January 15, 2012 and to reduce the size of the facility from \$50.0 million to \$37.5 million. The amended credit facility bears interest, at our option, at either the prime rate plus a margin or LIBOR plus a margin. The credit facility is collateralized by 65% of the ownership interests in our first-tier non-U.S. subsidiaries. The facility contains certain covenants and restrictions customary in lending transactions of this type, which among other things, restricts our ability and that of our subsidiaries to incur debt, incur liens, pay dividends or merge or consolidate with, or transfer all or substantially all assets to, another entity. The facility also requires maintenance of specified levels of net worth (as defined). In the event of a change of control, as defined, the lenders would have the right to accelerate the maturity of the facility.

In October 2007, CompX issued a \$52.6 million promissory note to TIMET in exchange for the shares of CompX previously owned by TIMET. See Note 3. The promissory note bears interest at LIBOR plus 1% (5.05% at December 31, 2008) and provides for quarterly principal repayments of \$250,000 commencing in September 2008, with the balance due at maturity in September 2014. CompX may make prepayments on the promissory note at any time, in any amount, without penalty, including \$2.6 million paid in the fourth quarter of 2007 and \$7.0 million paid during 2008. The promissory note is subordinated to CompX's U.S. revolving bank credit agreement.

Aggregate maturities of long-term debt at December 31, 2008

<u>Years ending December 31,</u>	<u>Amount</u> (In millions)
2009	\$ 9.4
2010	2.3
2011	57.8
2012	1.9
2013	561.0
2014 and thereafter	<u>288.0</u>
Total	<u>\$920.4</u>

Restrictions and other. Certain of the credit facilities described above require the borrower to maintain minimum levels of equity, require the maintenance of certain financial ratios, limit dividends and additional indebtedness and contain other provisions and restrictive covenants customary in lending transactions of this type. None of our credit agreements contain provisions that link the debt payment rates or schedules or borrowing availability to our or any of our subsidiaries credit ratings. At December 31, 2008, none of the net assets of Valhi's consolidated subsidiaries were restricted. While we were in compliance with all of our debt covenants at December 31, 2008, we currently believe it is probable that one of our required financial ratios associated with Kronos' European credit facility (the ratio of net secured debt to earnings before income taxes, interest and depreciation, as defined in the agreement) will not be maintained at some point during 2009, most likely commencing at March 31, 2009. In 2009, we have begun to reduce our production levels in response to the current economic environment, which we anticipate will favorably impact our liquidity and cash flows by reducing our inventory levels. However, the reduced capacity utilization levels will negatively impact on our Chemicals Segment's 2009 operating income due to the resulting unabsorbed fixed production costs that will be charged to expense as incurred. As a result, we may not be able to maintain the required financial ratio throughout 2009.

We have begun discussions with the lenders to amend the terms of the existing European credit facility to eliminate the requirement to maintain this financial ratio until at least March 31, 2010. While we believe it is possible we can obtain such an amendment to eliminate this financial ratio through at least March 31, 2010, there is no assurance that such amendment will be obtained, or if obtained that the requirement to maintain the financial ratio will be eliminated (or waived, in the event the lenders would only agree to a waiver and not an amendment to eliminate the covenant itself) through at least March 31, 2010. Any such amendment or waiver which we might obtain could increase our future borrowing costs, either from a requirement that we pay a higher rate of interest on outstanding borrowings or pay a fee to the lenders as part of agreeing to such amendment or waiver.

In the event we would not be successful in obtaining the amendment or waiver of the existing European credit facility to eliminate the requirement to maintain the financial ratio, we would seek to refinance such facility with a new group of lenders with terms that did not include such financial covenant or, if required, use our existing liquidity resources (which could include funds provided by our affiliates). While there is no assurance that we would be able to refinance the existing European credit facility with a new group of lenders, we believe these other sources of liquidity available to us would allow us to refinance the existing European credit facility. If required, we believe by undertaking one or more of these steps we would be successful in maintaining sufficient liquidity to meet our future obligations including operations, capital expenditures and debt service for the next 12 months.

At December 31, 2008, amounts available for the payment of Valhi dividends pursuant to the terms of Valhi's revolving bank credit facility aggregated \$.10 per Valhi share outstanding per quarter, plus an additional \$193.0 million. Any purchases of treasury stock by Valhi after December 31, 2008 would reduce this amount.

Note 10 - Accrued liabilities:

	<u>December 31,</u>	
	<u>2007</u>	<u>2008</u>
	(In millions)	
Current:		
Employee benefits	\$ 37.6	\$ 33.6
Environmental costs	15.4	11.6
Accrued sales discounts and rebates	15.3	14.9
Reserve for uncertain tax positions	.3	.2
Deferred income	4.0	8.4
Interest	8.3	7.9
Other	<u>52.3</u>	<u>51.8</u>
Total	<u>\$133.2</u>	<u>\$128.4</u>
Noncurrent:		
Reserve for uncertain tax positions	\$ 47.2	\$ 50.4
Insurance claims and expenses	15.2	13.5
Employee benefits	8.4	9.1
Deferred income	1.1	.9
Other	<u>5.8</u>	<u>4.9</u>
Total	<u>\$ 77.7</u>	<u>\$ 78.8</u>

The risks associated with certain of our accrued insurance claims and expenses have been reinsured, and the related IBNR receivables are recognized as noncurrent assets to the extent the related liability is classified as a noncurrent liability. See Note 7. Our reserve for uncertain tax positions is discussed in Note 18.

Note 11 - Employee benefit plans:

Defined contribution plans. We maintain various defined contribution pension plans for our employees worldwide. Defined contribution plan expense approximated \$3 million in each of 2006, 2007 and 2008.

Changes in accounting for defined benefit pension and postretirement benefits other than pension ("OPEB") plans. In September 2006, the FASB issued SFAS No. 158, *Employers' Accounting for Defined Benefit Pension and Other Postretirement Plans*. SFAS No. 158 requires us to recognize an asset or liability for the over or under funded status of each of our individual defined benefit pension and postretirement benefit plans on our Consolidated Balance Sheets. This standard did not change the existing recognition and measurement requirements that determine the amount of periodic benefit cost we recognize in net income. We adopted the asset and liability recognition and disclosure requirements of this standard effective December 31, 2006 on a prospective basis, in which we recognized through other comprehensive income all of our prior unrecognized gains and losses and prior service costs or credits, net of tax and minority interest, as of December 31, 2006. We now recognize all changes in the funded status of these plans through comprehensive income, net of tax and minority interest. Any future changes will be recognized either in net income, to the extent they are reflected in periodic benefit cost, or through other comprehensive income. In addition, prior to December 31, 2007 we used September 30th as a measurement date for certain of our pension plans.

In accordance with this standard, effective December 31, 2007 we transitioned all of our plans which had previously used a September 30th measurement date to a December 31st measurement date using a 15 month net periodic benefit cost. Accordingly one-fifth of the net periodic benefit cost for the period from October 1, 2006 through December 31, 2007, net of income taxes and minority interest, has been allocated as a direct adjustment to retained earnings to reflect this change and four-fifths of the cost was allocated to expense in 2007. To the extent the net periodic benefit cost included amortization of unrecognized actuarial losses, prior service cost and net transition obligations, which were previously recognized as a component of accumulated other comprehensive income at December 31, 2006, the effect on retained earnings, net of income taxes and minority interest, was offset by a change in accumulated other comprehensive income.

Defined benefit plans. Kronos, NL and one of our former business units sponsor various defined benefit pension plans worldwide. Prior to December 31, 2007 Kronos and NL used a September 30th measurement date for their defined benefit pension plans, and the former business unit used a December 31st measurement date. Effective December 31, 2007, all of our defined benefit pension plans now use a December 31st measurement date. The benefits under our defined benefit plans are based upon years of service and employee compensation. Our funding policy is to contribute annually the minimum amount required under ERISA (or equivalent foreign) regulations plus additional amounts as we deem appropriate.

We expect to contribute the equivalent of \$18.6 million to all of our defined benefit pension plans during 2009. Benefit payments to plan participants out of plan assets are expected to be the equivalent of:

2009	\$ 25.8 million
2010	26.0 million
2011	26.4 million
2012	28.5 million
2013	26.6 million
Next 5 years	144.1 million

The funded status of our defined benefit pension plans is presented in the table below.

	<u>Years ended December 31,</u>	
	<u>2007</u>	<u>2008</u>
	(In millions)	
Change in projected benefit obligations ("PBO"):		
Balance at beginning of the year	\$ 547.9	\$ 538.1
Service cost	7.9	9.6
Interest cost	26.8	23.7
Participants' contributions	2.1	1.9
Actuarial gains	(75.1)	(22.6)
Change in measurement date	7.9	-
Plan amendments	4.4	-
Change in foreign currency exchange rates	53.0	(49.9)
Benefits paid	<u>(36.8)</u>	<u>(30.9)</u>
Balance at end of the year	<u>\$ 538.1</u>	<u>\$ 469.9</u>
Change in plan assets:		
Fair value at beginning of the year	\$ 399.0	\$ 445.4
Actual return on plan assets	18.3	(75.6)
Employer contributions	28.0	21.2
Participants' contributions	2.1	1.9
Change in measurement date	(.6)	-
Change in foreign currency exchange rates	35.4	(38.5)
Benefits paid	<u>(36.8)</u>	<u>(30.9)</u>
Fair value at end of year	<u>\$ 445.4</u>	<u>\$ 323.5</u>
Funded status	<u>\$ (92.7)</u>	<u>\$ (146.4)</u>
Amounts recognized in the Consolidated Balance Sheets:		
Pension asset	\$ 47.6	\$ -
Accrued pension costs:		
Current	(.3)	(.3)
Noncurrent	<u>(140.0)</u>	<u>(146.1)</u>
Total	<u>(92.7)</u>	<u>(146.4)</u>
Accumulated other comprehensive loss:		
Actuarial losses	94.9	176.0
Prior service cost	6.6	5.6
Net transition obligations	<u>3.7</u>	<u>3.2</u>
Total	<u>105.2</u>	<u>184.8</u>
Total	<u>\$ 12.5</u>	<u>\$ 38.4</u>
Accumulated benefit obligations ("ABO")	<u>\$ 466.9</u>	<u>\$ 437.6</u>

The amounts shown in the table above for unrecognized actuarial losses, prior service cost and net transition obligations at December 31, 2007 and 2008 have not been recognized as components of our periodic defined benefit pension cost as of those dates. These amounts will be recognized as components of our periodic defined benefit cost in future years. In accordance with SFAS No. 158, these amounts, net of deferred income taxes and minority interest, are recognized in our accumulated other comprehensive income (loss) at December 31, 2007 and 2008. We expect approximately \$7.6 million, \$.9 million and \$.5 million of the unrecognized actuarial losses, prior service cost and net transition obligations, respectively, will be recognized as components of our periodic defined benefit pension cost in 2009. The table below details the changes in other comprehensive income (loss) during 2007 and 2008.

	<u>Years ended December 31,</u>	
	<u>2007</u>	<u>2008</u>
	(In millions)	
Changes in plan assets and benefit obligations recognized in other comprehensive income:		
Net actuarial gain (loss) arising during the year	\$69.6	\$(81.6)
Plan amendment	(4.4)	-
Change in measurement date:		
Prior service cost	.2	-
Transition obligations	.1	-
Actuarial losses	2.5	-
Amortization of unrecognized:		
Prior service cost	.7	.9
Net transition obligations	.5	.5
Net actuarial losses	<u>8.2</u>	<u>(1.1)</u>
Total	<u>\$77.4</u>	<u>\$(81.3)</u>

The components of our net periodic defined benefit pension cost are presented in the table below. In the fourth quarter of 2008 we recognized a \$6.9 million pension adjustment in connection with the correction of our pension expense previously recognized for 2006 and 2007. The \$6.9 million adjustment consisted of \$2.0 million of service cost, \$4.1 million of interest cost credit and \$4.8 million of recognized actuarial gains. The amounts shown below for the amortization of prior service cost, net transition obligations and recognized actuarial losses for 2007 and 2008 were recognized as components of our accumulated other comprehensive income (loss) at December 31, 2006 and 2007, respectively, net of deferred income taxes.

	<u>Years ended December 31,</u>		
	<u>2006</u>	<u>2007</u>	<u>2008</u>
	(In millions)		
Net periodic pension cost:			
Service cost	\$ 7.8	\$ 7.9	\$ 9.6
Interest cost	23.8	26.8	23.7
Expected return on plan assets	(25.7)	(28.5)	(31.7)
Amortization of unrecognized:			
Prior service cost	.6	.7	.9
Net transition obligations	.4	.5	.5
Net actuarial losses (gains)	<u>9.1</u>	<u>8.2</u>	<u>(1.1)</u>
Total	<u>\$ 16.0</u>	<u>\$ 15.6</u>	<u>\$ 1.9</u>

Certain information concerning our defined benefit pension plans is presented in the table below.

	<u>December 31,</u>	
	<u>2007</u>	<u>2008</u>
	(In millions)	
Projected benefit obligations:		
U.S. plans	\$ 87.4	\$ 87.8
Foreign plans	<u>450.7</u>	<u>382.1</u>
Total	<u>\$538.1</u>	<u>\$469.9</u>
Fair value of plan assets:		
U.S. plans	\$133.1	\$ 65.3
Foreign plans	<u>312.3</u>	<u>258.2</u>
Total	<u>\$445.4</u>	<u>\$323.5</u>
Plans for which the accumulated benefit obligations exceeds plan assets:		
Projected benefit obligations	\$287.4	\$420.0
Accumulated benefit obligations	240.6	397.0
Fair value of plan assets	164.4	279.2

A summary of our key actuarial assumptions used to determine benefit obligations asset as of December 31, 2007 and 2008 was:

	<u>December 31,</u>	
<u>Rate</u>	<u>2007</u>	<u>2008</u>
Discount rate	5.6%	5.9%
Increase in future compensation levels	2.5%	2.7%

A summary of our key actuarial assumptions used to determine net periodic benefit cost for 2006, 2007 and 2008 are as follows:

	<u>Years ended December 31,</u>		
<u>Rate</u>	<u>2006</u>	<u>2007</u>	<u>2008</u>
Discount rate	4.5%	4.9%	5.6%
Increase in future compensation levels	2.3%	2.5%	2.5%
Long-term return on plan assets	7.3%	7.3%	7.2%

Variances from actuarially assumed rates will result in increases or decreases in accumulated pension obligations, pension expense and funding requirements in future periods.

At December 31, 2007 and 2008, substantially all of the projected benefit obligations and plan assets attributable to our non-U.S. plans relate to plans maintained by our Chemicals Segment.

At December 31, 2007 and 2008, substantially all of the assets attributable to our U.S. plans were invested in the Combined Master Retirement Trust ("CMRT"), a collective investment trust sponsored by Contran to permit the collective investment by certain master trusts that fund certain employee benefits plans sponsored by Contran and certain of its affiliates.

The CMRT's long-term investment objective is to provide a rate of return exceeding a composite of broad market equity and fixed income indices (including the S&P 500 and certain Russell indices) while utilizing both third-party investment managers as well as investments directed by Mr. Simmons. Mr. Simmons is the sole trustee of the CMRT. The trustee of the CMRT, along with the CMRT's investment committee, of which Mr. Simmons is a member, actively manage the investments of the CMRT. The trustee and investment committee periodically change the asset mix of the CMRT based upon, among other things, advice they receive from third-party advisors and their expectations as to what asset mix will generate the greatest overall return. For the years ended December 31, 2006, 2007 and 2008, the assumed long-term rate of return for plan assets invested in the CMRT was 10%. In determining the appropriateness of the long-term rate of return assumption, we considered, among other things, the historical rates of return for the CMRT, the current and projected asset mix of the CMRT and the investment objectives of the CMRT's managers. During the history of the CMRT from its inception in 1987 through December 31, 2008, the average annual rate of return of the CMRT (excluding the CMRT's investment in TIMET common stock) has been 11%.

At December 31, 2008, subtrusts of the CMRT held 9% of TIMET's outstanding common stock and .1% of our outstanding common stock. These shares are not reflected in our Consolidated Financial Statements because we do not consolidate the CMRT.

At December 31, 2007 and 2008, plan assets attributable to our Chemicals Segment's foreign plans related primarily to Germany, Canada and Norway. In determining the expected long-term rate of return on plan asset assumptions for our foreign plans, we consider the long-term asset mix (e.g. equity vs. fixed income) for the assets for each of our plans and the expected long-term rates of return for the asset components. In addition, we receive advice about appropriate long-term rates of return from our third-party actuaries. The assumed asset mixes are summarized below:

- Germany - the composition of our plan assets is established to satisfy the requirements of the German insurance commissioner.
- Canada - we currently have a plan asset target allocation of 60% to equity securities and 40% to fixed income securities. We expect the long-term rate of return for such investments to average approximately 125 basis points above the applicable equity or fixed income index.
- Norway - we currently have a plan asset target allocation of 14% to equity securities, 64% to fixed income securities and the remainder to liquid investments such as money markets. The expected long-term rate of return for such investments is approximately 9.0%, 5.0% and 4.0%, respectively.

Our pension plan weighted average asset allocation by asset category were as follows:

	<u>December 31, 2007</u>			
	<u>CMRT</u>	<u>Germany</u>	<u>Canada</u>	<u>Norway</u>
Equity securities and limited Partnerships	98%	28%	60%	18%
Fixed income securities	-	49	34	68
Real estate	2	12	-	-
Cash, cash equivalents and other	-	11	6	14
Total	<u>100%</u>	<u>100%</u>	<u>100%</u>	<u>100%</u>

	<u>December 31, 2008</u>			
	<u>CMRT</u>	<u>Germany</u>	<u>Canada</u>	<u>Norway</u>
Equity securities and limited Partnerships	68%	24%	53%	14%
Fixed income securities	29	52	39	83
Real estate	2	12	-	-
Cash, cash equivalents and other	1	12	8	3
Total	<u>100%</u>	<u>100%</u>	<u>100%</u>	<u>100%</u>

We regularly review our actual asset allocation for each of our plans, and periodically rebalance the investments in each plan to more accurately reflect the targeted allocation when we consider it appropriate.

Postretirement benefits other than pensions (OPEB). NL, Kronos and Tremont provide certain health care and life insurance benefits for their eligible retired employees. Kronos, NL and Tremont each use a December 31st measurement date for their OPEB plans. We have no OPEB plan assets, rather, we fund benefit payments as they are paid. At December 31, 2008, we expect to contribute the equivalent of approximately \$3.2 million to all of our OPEB plans during 2009. Benefit payments to OPEB plan participants are expected to be the equivalent of:

2009	\$ 3.2 million
2010	3.2 million
2011	3.1 million
2012	3.0 million
2013	2.8 million
Next 5 years	12.3 million

The funded status of our OPEB plans is presented in the table below.

	<u>Years ended December 31,</u>	
	<u>2007</u>	<u>2008</u>
	(In millions)	
Actuarial present value of accumulated OPEB obligations:		
Balance at beginning of the year	\$ 37.4	\$ 37.1
Service cost	.3	.3
Interest cost	2.2	2.1
Actuarial gains	(.7)	(2.6)
Plan amendments	(.5)	-
Change in foreign currency exchange rates	1.3	(1.7)
Benefits paid from employer contributions	(2.9)	(2.7)
Balance at end of the year	<u>\$ 37.1</u>	<u>\$ 32.5</u>
Fair value of plan assets	<u>\$ -</u>	<u>\$ -</u>
Funded status	<u>\$ (37.1)</u>	<u>\$ (32.5)</u>
Accrued OPEB costs recognized in the Consolidated Balance Sheets:		
Current	\$ (3.5)	\$ (3.2)
Noncurrent	(33.6)	(29.3)
Total	<u>(37.1)</u>	<u>(32.5)</u>
Accumulated other comprehensive income (loss):		
Net actuarial losses (gains)	3.4	(1.4)
Prior service credit	(1.8)	.8
Total	<u>1.6</u>	<u>(.6)</u>
Total	<u>\$ (35.5)</u>	<u>\$ (33.1)</u>

The amounts shown in the table above for unrecognized actuarial losses and prior service credit at December 31, 2007 and 2008 have not been recognized as components of our periodic OPEB cost as of those dates. These amounts will be recognized as components of our periodic OPEB cost in future years. In accordance with SFAS No. 158, these amounts, net of deferred income taxes and minority interest, are now recognized in our accumulated other comprehensive income (loss) at December 31, 2007 and 2008. We expect to recognize approximately \$.1 million of the unrecognized actuarial losses and \$.4 million of prior service credit as components of our periodic OPEB cost in 2009. The table below details the changes in other comprehensive income during 2007 and 2008.

	<u>Years ended December 31,</u>	
	<u>2007</u>	<u>2008</u>
	(In millions)	
Changes in benefit obligations recognized in other comprehensive income (loss):		
Net actuarial loss arising during the year	\$.8	\$ 2.4
Plan amendments	.5	-
Amortization of unrecognized:		
Prior service cost	(.3)	(.4)
Net actuarial losses	.2	.2
Total	<u>\$ 1.2</u>	<u>\$ 2.2</u>

The components of our periodic OPEB cost are presented in the table below. The amounts shown below for the amortization of unrecognized actuarial gains/losses and prior service credit, net of deferred income taxes and minority interest, were recognized as components of our accumulated other comprehensive income (loss) at December 31, 2007 and 2008.

	<u>Years ended December 31,</u>		
	<u>2006</u>	<u>2007</u>	<u>2008</u>
	(In millions)		
Net periodic OPEB cost (credit):			
Service cost	\$.3	\$.3	\$.3
Interest cost	2.1	2.2	2.1
Amortization of unrecognized:			
Prior service credit	(.2)	(.3)	(.4)
Actuarial losses (gains)	<u>.1</u>	<u>.2</u>	<u>.2</u>
Total	<u>\$2.3</u>	<u>\$2.4</u>	<u>\$2.2</u>

A summary of our key actuarial assumptions used to determine the net benefit obligations as of December 31, 2007 and 2008 follows:

	<u>December 31,</u>	
	<u>2007</u>	<u>2008</u>
Healthcare inflation:		
Initial rate	5.8% - 8.5%	5.5% - 8.0%
Ultimate rate	4.0% - 5.5%	5.5%
Year of ultimate rate achievement	2010 - 2014	2015
Discount rate	6.1%	5.9%

Assumed health care cost trend rates have a significant effect on the amounts we report for health care plans. A one percent change in assumed health care trend rates would have the following effects:

	<u>1% Increase</u>	<u>1% Decrease</u>
	(In millions)	
Effect on net OPEB cost during 2008	\$.3	\$ (.2)
Effect at December 31, 2008 on postretirement obligations	2.5	(2.2)

The weighted average discount rate used in determining the net periodic OPEB cost for 2008 was 6.0% (the rate was 5.8% in 2007 and 5.5% in 2006). The weighted average rate was determined using the projected benefit obligations as of the beginning of each year.

Variances from actuarially-assumed rates will result in additional increases or decreases in accumulated OPEB obligations, net periodic OPEB cost and funding requirements in future periods.

The Medicare Prescription Drug, Improvement and Modernization Act of 2003 provides a federal subsidy to sponsors of retiree health care benefit plans that provide a prescription drug benefit that is at least actuarially equivalent to Medicare Part D. We are eligible for the federal subsidy. We account for the effect of this subsidy prospectively from the date we determined actuarial equivalence. The subsidy did not have a material impact on the applicable accumulated postretirement benefit obligation, and will not have a material impact on the net periodic OPEB cost going forward.

Note 12 - Income taxes:

	<u>Years ended December 31,</u>		
	<u>2006</u>	<u>2007</u>	<u>2008</u>
	(In millions)		
Pre-tax income:			
United States	\$ 151.4	\$ 3.0	\$ 8.8
Non-U.S. subsidiaries	66.1	51.0	12.8
Total	<u>\$ 217.5</u>	<u>\$ 54.0</u>	<u>\$ 21.6</u>
Expected tax expense, at U.S. federal statutory income tax rate of 35%	\$ 76.1	\$ 18.9	\$ 7.5
Non-U.S. tax rates	(2.1)	.1	(.6)
Incremental U.S. tax and rate differences on equity in earnings	18.4	(14.1)	4.3
German tax attribute adjustment	(21.7)	8.7	(7.2)
Assessment (refund) of prior year income taxes, net	(1.4)	(.8)	.1
U.S. state income taxes, net	2.9	1.5	2.0
Tax contingency reserve adjustment, net	(10.4)	(3.8)	5.6
No income tax benefit on goodwill impairment	-	-	3.5 ⁽²⁾
Nondeductible expenses	4.9	3.6	2.6
German tax rate change	-	87.4	-
Canadian tax rate change	(1.3)	.4	-
Nontaxable income	(1.1)	(.6)	(1.0)
Other, net	(0.5)	1.9	(0.1)
Provision for income taxes	<u>\$ 63.8</u>	<u>\$103.2</u>	<u>\$ 16.7</u>
Components of income tax expense (benefit):			
Currently payable (refundable):			
U.S. federal and state	\$ 2.1	\$ (1.9)	\$ 12.8
Non-U.S.	24.4	14.4	11.3
Total	<u>26.5</u>	<u>12.5</u>	<u>24.1</u>
Deferred income taxes (benefit):			
U.S. federal and state	71.3	(11.3)	4.3
Non-U.S.	(34.0)	102.0	(11.7)
Total	<u>37.3</u>	<u>90.7</u>	<u>(7.4)</u>
Provision for income taxes	<u>\$ 63.8</u>	<u>\$103.2</u>	<u>\$ 16.7</u>
Comprehensive provision for income taxes (benefit) allocable to:			
Income from operations	\$ 63.8	\$103.2	\$ 16.7
Dividend of TIMET common stock	-	668.3 ⁽¹⁾	-
Other comprehensive income:			
Marketable securities	3.3	11.3	(15.6)
Currency translation	9.6	8.7	(10.0)
Pension plans	9.2	38.5	(32.7)
OPEB plans	-	.5	.9
Other	-	(.6)	-
Adoption of SFAS No. 158:			
Pension plans	(19.6)	(1.4)	-
OPEB plans	(1.7)	-	-
Total	<u>\$ 64.6</u>	<u>\$828.5</u>	<u>\$ (40.7)</u>

(1) Represents the current income taxes generated at the Valhi level and the associated utilization of NOL and AMT carryforwards resulting from the TIMET special dividend. See Note 3.

(2) The goodwill impairment charge of \$10.1 million recorded in 2008 (see Note 8) is nondeductible goodwill for income tax purposes. Accordingly, there is no income tax benefit associated with the goodwill impairment for financial reporting purposes.

The components of the net deferred tax liability at December 31, 2007 and 2008 are summarized below.

	December 31,			
	2007		2008	
	<u>Assets</u>	<u>Liabilities</u>	<u>Assets</u>	<u>Liabilities</u>
	(In millions)			
Tax effect of temporary differences related to:				
Inventories	\$ 1.6	\$ (3.2)	\$ 1.8	\$ (4.6)
Marketable securities	4.4	(116.6)	19.9	(113.5)
Property and equipment	.5	(81.9)	.4	(78.4)
Accrued OPEB costs	12.3	-	10.9	-
Pension asset	-	(17.3)	-	-
Accrued pension costs	8.8	-	14.0	-
Accrued environmental liabilities and other deductible differences	49.6	-	50.9	-
Other taxable differences	-	(27.6)	-	(28.1)
Investments in subsidiaries and affiliates	-	(231.0)	-	(216.7)
Tax loss and tax credit carryforwards	164.2	-	171.8	-
Valuation allowance	(3.0)	-	(1.2)	-
Adjusted gross deferred tax assets (liabilities)	238.4	(477.6)	268.5	(441.3)
Netting of items by tax jurisdiction	(59.3)	59.3	(90.0)	90.0
	179.1	(418.3)	178.5	(351.3)
Less net current deferred tax asset (liability)	10.4	(3.3)	12.1	(4.7)
Net noncurrent deferred tax asset (liability)	<u>\$168.7</u>	<u>\$(415.0)</u>	<u>\$ 166.4</u>	<u>\$(346.6)</u>

Our Chemicals Segment has received a notice of proposed adjustment from the Canadian tax authorities related to the years 2002 through 2004. We object to the proposed assessment and intend to formally respond to the Canadian tax authorities in March 2009. Because of the inherent uncertainties involved in the settlement of the potential exposure, if any, the final outcome is also uncertain. We believe we have provided adequate reserves.

During 2008, we recognized a \$7.2 million non-cash deferred income tax benefit related to a European Court ruling that resulted in the favorable resolution of certain income tax issues in Germany and an increase in the amount of our German corporate and trade tax net operating loss carryforwards.

Following a European Union Court of Justice decision and subsequent proceedings which concluded in 2007 that we believe may favorably impact us, we initiated a new tax planning strategy. If we are successful, we would generate a substantial cash tax benefit in the form of refunds of income taxes we have previously paid in Europe, which we currently do not expect to affect our future earnings when received. It may be a number of years before we know if our implementation of this tax planning strategy will be successful, and accordingly we have not currently recognized any refundable income taxes that we might ultimately receive. Partially as a result of, and consistent with, our initiation of this new tax planning strategy, in 2007 we amended prior-year income tax returns in Germany. As a consequence of amending our tax returns, our German corporate and trade tax net operating loss carryforwards were reduced by an aggregate of euro 13.4 million and euro 22.6 million, respectively. Accordingly, we recognized an \$8.7 million provision for deferred income taxes in 2007 related to the adjustment of our German tax attributes.

In August 2007, Germany enacted certain changes in their income tax laws. The most significant change was the reduction of the German corporate and trade income tax rates. We have a significant net deferred income tax asset in Germany, primarily related to the benefit associated with our corporate and trade tax net operating loss carryforwards. We measure our net deferred taxes using the applicable enacted tax rates, and the effect of any change in the applicable enacted tax rate is recognized in the period of enactment. Accordingly, we reported a decrease in our net deferred tax asset in Germany of \$87.4 million in 2007, which is recognized as a component of our provision for income taxes.

In June 2006, Canada enacted a 2% reduction in the Canadian federal income tax rate and the elimination of the federal surtax. The 2% reduction will be phased in from 2008 to 2010, and the federal surtax was eliminated in 2008. As a result, during 2006 we recognized a \$1.3 million income tax benefit related to the effect of such reduction on our previously-recorded net deferred income tax liability with respect to Kronos' and CompX's operations in Canada.

Due to the resolution of certain income tax audits in Germany, we also recognized a \$21.7 million income tax benefit in 2006 primarily related to an increase in the amount of our German trade tax net operating loss carryforward. The increase resulted from a reallocation of expenses between our German units related to periods in which such units did not file on a consolidated basis for German trade tax purposes, with the net result that the amount of our German trade tax carryforward recognized by the German tax authorities has increased.

Principally as a result of the withdrawal of tax assessments previously made by Belgian and Norwegian tax authorities and the resolution of our ongoing income tax audits in Germany, we recognized a \$10.4 million income tax benefit in 2006 related to the total reduction in our income tax contingency reserve.

Due to the favorable resolution of certain income tax audits related to our German and Belgian operations during 2006, we recognized a net \$1.4 million income tax benefit related to adjustments of prior year income taxes.

Tax authorities are continuing to examine certain of our foreign tax returns and have or may propose tax deficiencies, including penalties and interest. We cannot guarantee that these tax matters will be resolved in our favor due to the inherent uncertainties involved in settlement initiatives and court and tax proceedings. We believe we have adequate accruals for additional taxes and related interest expense which could ultimately result from tax examinations. We believe the ultimate disposition of tax

examinations should not have a material adverse effect on our consolidated financial position, results of operations or liquidity.

At December 31, 2008, Kronos had the equivalent of \$817 million and \$229 million of the net operating loss carryforwards for German corporate and trade tax purposes, respectively, all of which have no expiration date and CompX had \$.4 million of U.S. net operating loss carryforwards expiring in 2009 through 2017. At December 31, 2008, the U.S. net operating loss carryforwards of CompX are limited in utilization to approximately \$.4 million per year.

Note 13 - Minority interest:

	<u>December 31,</u>	
	<u>2007</u>	<u>2008</u>
	(In millions)	
Minority interest in net assets:		
NL Industries	\$ 55.6	\$ 45.8
Kronos Worldwide	20.5	15.6
CompX International	<u>14.4</u>	<u>11.9</u>
Total	<u>\$ 90.5</u>	<u>\$ 73.3</u>

	<u>Years ended December 31,</u>		
	<u>2006</u>	<u>2007</u>	<u>2008</u>
	(In millions)		
Minority interest in after-tax earnings (losses):			
NL Industries	\$ 4.4	\$ (2.8)	\$ 5.6
Kronos Worldwide	4.1	(3.3)	.4
CompX International	<u>3.5</u>	<u>2.6</u>	<u>(.3)</u>
Total	<u>\$12.0</u>	<u>\$ (3.5)</u>	<u>\$ 5.7</u>

Note 14 - Stockholders' equity:

	<u>Shares of common stock</u>		
	<u>Issued</u>	<u>Treasury</u>	<u>Outstanding</u>
	(In millions)		
Balance at December 31, 2005	120.8	(4.0)	116.8
Acquired	-	(1.9)	(1.9)
Retired	<u>(1.9)</u>	<u>1.9</u>	<u>-</u>
Balance at December 31, 2006	118.9	(4.0)	114.9
Issued	.1	-	.1
Acquired	-	(.6)	(.6)
Retired	<u>(.6)</u>	<u>.6</u>	<u>-</u>
Balance at December 31, 2007	118.4	(4.0)	114.4
Acquired	<u>-</u>	<u>(.1)</u>	<u>(.1)</u>
Balance at December 31, 2008	<u>118.4</u>	<u>(4.1)</u>	<u>114.3</u>

The shares of Valhi common stock issued during the past three years consist of employee stock options exercises and stock awards issued annually to members of our board of directors.

Valhi share repurchases and cancellations. Prior to 2006, our board of directors authorized the repurchase of up to 5.0 million shares of our common stock in open market transactions, including block purchases, or in privately negotiated transactions, which may include transactions with our affiliates or subsidiaries. In 2006, our board of directors authorized the repurchase of an additional 5.0 million shares. We may purchase the stock from time to time as market conditions permit. The stock repurchase program does not include specific price targets or timetables and may be suspended at any time. Depending on market conditions, we may terminate the program prior to completion. We will use cash on hand to acquire the shares. Repurchased shares could be retired and cancelled or may be added to our treasury stock and used for employee benefit plans, future acquisitions or other corporate purposes. During 2006 and 2007, we purchased approximately 1.9 million and .6 million shares, respectively, of our common stock pursuant to this repurchase program in market or other transactions for an aggregate of \$43.8 million and \$11.1 million, respectively.

During 2006 and 2007, we cancelled 1.9 million and .6 million of our treasury shares, respectively, and allocated their cost to common stock at par value, additional paid-in capital and retained earnings. These cancellations had no impact on our net shares outstanding for financial reporting purposes.

Treasury stock. The treasury stock we reported for financial reporting purposes at December 31, 2006, 2007 and 2008 represented our proportional interest in the shares of our common stock held by NL. NL held 4.7 million Valhi shares at December 31, 2006 and 2007 and 4.8 million shares at December 31, 2008. NL purchased approximately 79,000 shares of our common stock in open market transactions during the fourth quarter of 2008 for an aggregate purchase price of \$1.1 million. Under Delaware Corporation Law, 100% (and not the proportionate interest) of a parent company's shares held by a majority-owned subsidiary of the parent is considered to be treasury stock for voting purposes. As a result, our common shares outstanding for financial reporting purposes differ from those outstanding for legal purposes.

Preferred stock. As discussed in Note 3, in 2007 we incurred a tax obligation to Contran upon payment of the special dividend in the amount of \$667.7 million. In order to discharge \$667.3 million of this tax obligation, in March 2007 we issued to Contran 5,000 shares of a new issue of our Series A Preferred Stock having a liquidation preference of \$133,466.75 per share, or an aggregate liquidation preference of \$667.3 million. The 5,000 preferred shares we issued to Contran represents all of the shares of Series A Preferred Stock we are authorized to issue. The preferred stock has a par value of \$.01 per share and pays a non-cumulative cash dividend at an annual rate of 6% of the aggregate liquidation preference only when authorized and declared by our board of directors. The shares of Series A Preferred Stock are non-convertible, and the shares do not carry any redemption or call features (either at our option or the option of the holder). A holder of the Series A shares does not have any voting rights, except in limited circumstances, and is not entitled to a preferential dividend right that is senior to our shares of common stock. Upon the liquidation, dissolution or winding up of our affairs, a holder of the Series A shares is entitled to be paid a liquidation preference of \$133,466.75 per share, plus an amount (if any) equal to any declared but unpaid dividends, before any distribution of assets is made to holders of our common stock. We recorded the shares of Series A Preferred Stock issued to Contran at \$667.3 million, representing the amount of the discharged tax obligation. We did not declare any dividends on the Series A Preferred Stock through December 31, 2008.

Valhi stock options and restricted stock. We have an incentive stock option plan that provides for the discretionary grant of, among other things since its five year extension, nonqualified stock options, restricted common stock, stock awards and stock appreciation rights. We may issue up to 5 million shares of our common stock pursuant to this plan. We grant options at the fair market value on the date of grant. The options generally vest ratably over a five-year period beginning one year from the date of grant and expire 10 years from the date of grant. If we grant restricted stock, it is generally forfeitable unless certain periods of employment are completed. Our outstanding options at December 31, 2008 represent less than 1% of our outstanding shares and expire at various dates through 2013, with a weighted-average remaining term of .8 years. At December 31, 2008, approximately 295,000 options remained outstanding exercisable at prices ranging from \$11.00 - \$12.00 per share. At December 31, 2008, these options have an aggregate amount payable upon exercise of \$3.4 million and a negative aggregate intrinsic value (defined as the excess of the market price of our common stock over the exercise price) of \$.3 million. At December 31, 2008, 4.3 million shares were available for grant under the plan. The intrinsic value of Valhi options exercised at the various dates of exercise aggregated approximately \$.4 million in 2006, \$1.6 million in 2007 and the related income tax benefit from such exercises was approximately \$.1 million in 2006 and \$.6 million in 2007. Option exercises in 2008 were not material.

Stock option plans of subsidiaries and affiliate. NL and CompX maintain plans which provide for the grant of options to purchase their common stocks. Provisions of these plans vary by company. Outstanding options to purchase common stock of NL and CompX at December 31, 2008 are summarized below. There are no outstanding options to purchase Kronos common stock at December 31, 2008.

	<u>Shares</u> (In thousands)	<u>Exercise price per share</u>	<u>Amount payable upon exercise</u> (In millions)
NL Industries	95	\$ 2.66 - \$11.49	\$.9
CompX	134	12.15 - 19.25	2.3

Note 15 - Other income, net:

	<u>Years ended December 31,</u>		
	<u>2006</u>	<u>2007</u>	<u>2008</u>
	(In millions)		
Securities earnings:			
Dividends and interest	\$41.6	\$30.9	\$31.9
Securities transactions, net	.7	(.1)	(1.2)
Total	42.3	30.8	30.7
Insurance recoveries	7.7	6.1	9.6
Currency transactions, net	(3.5)	(.8)	1.3
Disposal of property and equipment, net	35.3	(1.3)	(1.0)
Litigation settlement gain	-	-	47.9
Other, net	8.1	7.5	5.2
Total	<u>\$89.9</u>	<u>\$42.3</u>	<u>\$93.7</u>

Dividends and interest income includes distributions from The Amalgamated Sugar Company LLC of \$31.1 million in 2006 and \$25.4 million in each of 2007 and 2008.

Insurance recoveries in 2006, 2007 and 2008 relate to amounts NL has received from certain of its former insurance carriers, and relate principally to recovery of prior lead pigment and asbestos litigation defense costs incurred by NL. We have agreements with two former insurance carriers pursuant to which the carriers will reimburse us for a portion of our past and future lead pigment litigation defense costs, and one such carrier reimburses us for a portion of our asbestos litigation defense costs. The insurance recoveries were recognized in each year include amounts we received from these carriers. We are not able to determine how much we will ultimately recover from the carriers for the past defense costs incurred because of certain issues that arise regarding which past defense costs qualify for reimbursement. Insurance recoveries in 2006 also include amounts we received for prior legal defense and indemnity coverage for certain of our environmental expenditures. We do not expect to receive any further material insurance settlements relating to environmental remediation matters.

While we continue to seek additional insurance recoveries for lead pigment and asbestos litigation matters, we do not know the extent to which if we will be successful in obtaining additional reimbursement for either defense costs or indemnity. We recognize insurance recoveries in income only when receipt of the recovery is probable and we are able to reasonably estimate the amount of the recovery.

In 2006, we sold certain land we owned in Henderson, Nevada for net proceeds of \$37.9 million. We recognized a \$36.4 million gain on the sale. The land was not used in any of our operations.

In 2005, certain real property NL owned that is subject to environmental remediation, was taken from us in a condemnation proceeding by a governmental authority in New Jersey. The condemnation proceeds, the adequacy of which NL disputed, were placed into escrow with a court in New Jersey. Because the funds were in escrow with the court and were beyond our control, we never gave recognition to such condemnation proceeds for financial reporting purposes. In April 2008, we reached a tentative settlement agreement with such governmental authority and a real estate developer, among others, pursuant to which, among other things, NL would receive certain agreed-upon amounts in satisfaction of its claim to just compensation for the taking of its property in the condemnation proceeding and would be indemnified against certain environmental liabilities related to such property. The tentative settlement agreement was subject to certain conditions which ultimately were not met, and on May 2, 2008 we terminated the agreement. In late June 2008 the settlement agreement was reinstated, and the initial closing under the reinstated settlement agreement occurred in October 2008. At the initial October 2008 closing, NL received aggregate proceeds of \$54.6 million, comprising \$39.6 million in cash plus a promissory note in the amount of \$15.0 million, in exchange for the release of its equitable lien on a portion of the property. The agreement calls for two subsequent closings that are scheduled to take place in April 2009 and October 2010, respectively, and that are subject to, among other things, NL's receipt of certain additional payments. In exchange for the additional payments NL would receive at the two subsequent closings, NL would release its equitable lien on the remaining two portions of the property. The settlement agreement provides for the dismissal of the pending condemnation proceeding with prejudice. Our carrying value of this property was approximately \$7.5 million at the time of the October agreement.

The \$15.0 million promissory note NL received bears interest at LIBOR plus 2.75%, with interest payable monthly. All principal is due no later than October 2011. The promissory note is collateralized by the real estate developer's ground lease on the property, and all improvements to the property performed by the developer. Both the promissory note and NL's lien on the property are subordinated to certain senior indebtedness of the developer. In the event that the developer has not repaid the promissory note at its stated maturity, we have the right to demand repayment of up to \$15.0 million due under the promissory note from one of the developer's equity partners, and such right is not subordinated to the developer's senior indebtedness.

For financial reporting purposes, we have accounted for the aggregate consideration received at the October 2008 closing of the reinstated settlement agreement by the full accrual method of accounting for real estate sales (since the settlement agreement arose out of a dispute concerning the adequacy of the condemnation proceeds for our former real property in New Jersey). Under this method, we recognized a \$47.9 million pre-tax gain in the fourth quarter of 2008. Similarly, the cash consideration we received at the initial closing is reflected, and the proceeds from collecting the principal on the \$15.0 million promissory note will be reflected, as an investing activity in our Consolidated Statement of Cash Flows.

In addition to the consideration NL received at the October 2008 closing, as part of the April 2008 agreement NL became entitled to receive the interest that had accrued on the escrow funds, and in May 2008 we received approximately \$4.3 million of such interest, which we recognized as interest income in 2008.

Note 16 - Related party transactions:

We may be deemed to be controlled by Mr. Harold C. Simmons. See Note 1. We and other entities that may be deemed to be controlled by or affiliated with Mr. Simmons sometimes engage in (a) intercorporate transactions such as guarantees, management and expense sharing arrangements, shared fee arrangements, joint ventures, partnerships, loans, options, advances of funds on open account, and sales, leases and exchanges of assets, including securities issued by both related and unrelated parties, and (b) common investment and acquisition strategies, business combinations, reorganizations, recapitalizations, securities repurchases, and purchases and sales (and other acquisitions and dispositions) of subsidiaries, divisions or other business units. These transactions have involved both related and unrelated parties and have included transactions which resulted in the acquisition by one related party of a publicly-held minority equity interest in another related party. We periodically consider, review and evaluate, and understand that Contran and related entities consider, review and evaluate such transactions. Depending upon the business, tax and other objectives then relevant, it is possible we might be a party to one or more such transactions in the future.

From time to time, we will have loans and advances outstanding between us and various related parties, including Contran, pursuant to term and demand notes. We generally enter into these loans and advances for cash management purposes. When we loan funds to related parties, we are generally able to earn a higher rate of return on the loan than we would earn if we invested the funds in other instruments. While certain of these loans may be of a lesser credit quality than cash equivalent instruments otherwise available to us, we believe we have evaluated the credit risks involved and appropriately reflect those credit risks in the terms of the applicable loans. When we borrow from related parties, we are generally able to pay a lower rate of interest than we would pay if we borrowed from unrelated parties.

In October 2007, the independent members of CompX's board of directors authorized the repurchase or cancellation of a net 2.7 million shares of its Class A common stock held by TIMET, including the Class A shares held indirectly by TIMET through its ownership interest in CompX Group. CompX purchased these shares for \$19.50 per share, or aggregate consideration of \$52.6 million, which it paid in the form of a promissory note. The price per share was determined based on CompX's open market repurchases of its Class A common stock around the time the repurchase was approved. The promissory note bears interest at LIBOR plus 1% and provides for quarterly principal repayments of \$250,000 commencing in September 2008, with the balance due at maturity in September 2014. CompX may make prepayments on the promissory note at any time, in any amount, without penalty. The promissory note is subordinated to CompX's U.S. revolving bank credit agreement. Interest expense related to CompX's note payable to TIMET was \$.6 million and \$2.2 million in 2007 and 2008, respectively. See Notes 3 and 9.

Under the terms of various intercorporate services agreements ("ISAs") we enter into with Contran, employees of Contran provide us certain management, tax planning, financial and administrative services on a fee basis. Such charges are based upon estimates of the time devoted by the Contran employees to our affairs, and the compensation and other expenses associated with those persons. Because of the large number of companies affiliated with Contran, we believe we benefit from cost savings and economies of scale gained by not having certain management, financial and administrative staffs duplicated at all of our subsidiaries, thus allowing certain Contran employees to provide services to multiple companies but only be compensated by Contran. The net ISA fees charged to us by Contran and approved by the independent members of the applicable board of directors aggregated \$23.7 million in 2006, \$23.4 million in 2007 and \$22.5 million in 2008. The 2006 amount includes a full year of ISA fees paid by TIMET because we disposed of substantially all of our TIMET shares at the end of the first quarter of 2007 (see Note 3), while the 2007 amount includes only three months of ISA fees paid by TIMET. The 2008 amount does not include any ISA fees paid by TIMET.

Tall Pines Insurance Company and EWI RE, Inc. provide for or broker certain insurance or reinsurance policies for Contran and certain of its subsidiaries and affiliates, including us. Tall Pines and EWI are our subsidiaries. Consistent with insurance industry practices, Tall Pines and EWI receive commissions from the insurance and reinsurance underwriters and/or assess fees for the policies that they provide or broker to us. Tall Pines purchases reinsurance for substantially all of the risks it underwrites. We expect these relationships with Tall Pines and EWI will continue in 2009.

Contran and certain of its subsidiaries and affiliates, including us, purchase certain of their insurance policies as a group, with the costs of the jointly-owned policies being apportioned among the participating companies. With respect to some of these policies, it is possible that unusually large losses incurred by one or more insureds during a given policy period could leave the other participating companies without adequate coverage under that policy for the balance of the policy period. As a result, we and Contran have entered into a loss sharing agreement under which any uninsured loss is shared by those entities who have submitted claims under the relevant policy. We believe the benefits in the form of reduced premiums and broader coverage associated with the group coverage for such policies justifies the risk associated with the potential of any uninsured loss.

Basic Management, Inc., among other things, provides utility services (primarily water distribution, maintenance of a common electrical facility and sewage disposal monitoring) to TIMET and other manufacturers within an industrial complex located in Nevada. The other owners of BMI are generally the other manufacturers located within the complex. BMI provides power transmission and sewer services on a cost reimbursement basis, similar to a cooperative, while water delivery is currently provided at the same rates as are charged by BMI to an unrelated third party. Amounts paid by TIMET to BMI for these utility services were \$2.3 million in 2006, \$2.2 million in 2007 and \$2.3 million in 2008. TIMET also paid BMI an electrical facilities upgrade fee of \$.8 million in each of 2006, 2007 and 2008. This \$.8 million annual fee is scheduled to terminate after January 2010.

COAM Company is a partnership which has a sponsored research agreement with the University of Texas Southwestern Medical Center at Dallas to develop and commercially market patents and technology resulting from a cancer research program (the "Cancer Research Agreement"). At December 31, 2008, we are a partner of COAM along with Contran and another Contran subsidiary. Mr. Harold C. Simmons is the manager of COAM. The Cancer Research Agreement, as amended, provides for funds of up to \$34 million through 2015. Funding requirements pursuant to the Cancer Research Agreement is without recourse to the COAM partners and the partnership agreement provides that no partner shall be required to make capital contributions. Capital contributions are expensed as paid. We have not made contributions to COAM during the past three years, and we do not expect we will make any capital contributions to COAM in 2009.

We provide certain research, laboratory and quality control services within and outside the sweetener industry for The Amalgamated Sugar Company LLC and others. We have also granted to The Amalgamated Sugar Company LLC a non-exclusive, royalty-free perpetual license to use all currently existing or hereafter developed technology which is applicable to sugar operations and provides for payment of certain royalties to The Amalgamated Sugar Company LLC from future sales or licenses of the subsidiary's technology to third parties. Research and development services charged to The Amalgamated Sugar Company LLC and included in other income was \$1.1 million in each of 2006 and 2007 and \$1.2 million in 2008. The Amalgamated Sugar Company LLC provides certain administrative services to us, and the cost of such services (based upon estimates of the time devoted by employees of the LLC to our affairs, and the compensation of such persons) is considered in the agreed-upon research and development services fee paid by the LLC to us and is not separately quantified. In January 2009, we sold our research, laboratory and quality control business to the LLC for an aggregate sales price of \$7.5 million, consisting of \$6.75 million in cash paid at closing and \$500,000 in notes payable in February 2010 and \$250,000 in notes payable in February 2011. We will recognize a \$6.4 million pre-tax gain on the sale in the first quarter of 2009. The revenues, pre-tax income and total assets of the operations sold are not material in any period presented.

Receivables from and payables to affiliates are summarized in the table below.

	<u>December 31,</u>	
	<u>2007</u>	<u>2008</u>
	(In millions)	
Current receivables from affiliates:		
Contran - income taxes, net	\$ 4.4	\$ -
Other	<u>.2</u>	<u>.1</u>
Total	<u>\$ 4.6</u>	<u>\$.1</u>
Current payables to affiliates:		
Louisiana Pigment Company	\$11.4	\$14.3
Contran:		
Income taxes, net	-	1.3
Trade items	7.1	9.7
TIMET	<u>.5</u>	<u>.5</u>
Total	<u>\$19.0</u>	<u>\$25.8</u>
CompX promissory note payable to TIMET ⁽¹⁾	<u>\$50.0</u>	<u>\$43.0</u>

⁽¹⁾ Included in long-term debt.

Payables to Louisiana Pigment Company are primarily for the purchase of TiO₂. Our purchases in the ordinary course of business from LPC are disclosed in Note 7. Substantially all of the Contran trade payables relates to the ISA fees charged to WCS by Contran, which ISA fees WCS has not paid the ISA fee to Contran since 2001. See Notes 3 and 9 for more information on the CompX note payable to TIMET.

Note 17 - Commitments and contingencies:

Lead pigment litigation - NL

NL's former operations included the manufacture of lead pigments for use in paint and lead-based paint. NL, other former manufacturers of lead pigments for use in paint and lead-based paint (together, the "former pigment manufacturers"), and the Lead Industries Association ("LIA"), which discontinued business operations in 2002, have been named as defendants in various legal proceedings seeking damages for personal injury, property damage and governmental expenditures allegedly caused by the use of lead-based paints. Certain of these actions have been filed by or on behalf of states, counties, cities or their public housing authorities and school districts, and certain others have been asserted as class actions. These lawsuits seek recovery under a variety of theories, including public and private nuisance, negligent product design, negligent failure to warn, strict liability, breach of warranty, conspiracy/concert of action, aiding and abetting, enterprise liability, market share or risk contribution liability, intentional tort, fraud and misrepresentation, violations of state consumer protection statutes, supplier negligence and similar claims.

The plaintiffs in these actions generally seek to impose on the defendants responsibility for lead paint abatement and health concerns associated with the use of lead-based paints, including damages for personal injury, contribution and/or indemnification for medical expenses, medical monitoring expenses and costs for educational programs. To the extent the plaintiffs seek compensatory or punitive damages in these actions, such damages are generally unspecified. In some cases, the damages are unspecified pursuant to the requirements of applicable state law. A number of cases are inactive or have been dismissed or withdrawn. Most of the remaining cases are in various pre-trial stages. Some are on appeal following dismissal or

summary judgment rulings in favor of either the defendants or the plaintiffs. In addition, various other cases are pending (in which we are not a defendant) seeking recovery for injury allegedly caused by lead pigment and lead-based paint. Although we are not a defendant in these cases, the outcome of these cases may have an impact on cases that might be filed against us in the future.

We believe that these actions are without merit, and we intend to continue to deny all allegations of wrongdoing and liability and to defend against all actions vigorously. We do not believe it is probable that we have incurred any liability with respect to all of the lead pigment litigation cases to which we are a party, and liability to us that may result, if any, in this regard cannot be reasonably estimated, because:

- we have never settled any of these cases;
- no final, non-appealable adverse verdicts have ever been entered against us; and
- we have never ultimately been found liable with respect to any such litigation matters.

Accordingly, we have not accrued any amounts for any of the pending lead pigment and lead-based paint litigation cases. New cases may continue to be filed against us. We cannot assure you that we will not incur liability in the future in respect of any of the pending or possible litigation in view of the inherent uncertainties involved in court and jury rulings. The resolution of any of these cases could result in recognition of a loss contingency accrual that could have a material adverse impact on our results of operations for the interim or annual period during which such liability is recognized, and a material adverse impact on our consolidated financial condition and liquidity.

Environmental matters and litigation

General - Our operations are governed by various environmental laws and regulations. Certain of our businesses are and have been engaged in the handling, manufacture or use of substances or compounds that may be considered toxic or hazardous within the meaning of applicable environmental laws and regulations. As with other companies engaged in similar businesses, certain of our past and current operations and products have the potential to cause environmental or other damage. We have implemented and continue to implement various policies and programs in an effort to minimize these risks. Our policy is to maintain compliance with applicable environmental laws and regulations at all of our plants and to strive to improve our environmental performance. From time to time, we may be subject to environmental regulatory enforcement under U.S. and foreign statutes, the resolution of which typically involves the establishment of compliance programs. It is possible that future developments, such as stricter requirements of environmental laws and enforcement policies, could adversely affect our production, handling, use, storage, transportation, sale or disposal of such substances. We believe that all of our facilities are in substantial compliance with applicable environmental laws.

Certain properties and facilities used in our former operations, including divested primary and secondary lead smelters and former mining locations of NL, are the subject of civil litigation, administrative proceedings or investigations arising under federal and state environmental laws. Additionally, in connection with past disposal practices, we are currently involved as a defendant, potentially responsible party ("PRP") or both, pursuant to the Comprehensive Environmental Response, Compensation and Liability Act, as amended by the Superfund Amendments and Reauthorization Act ("CERCLA"), and similar state laws in various governmental and private actions associated with waste disposal sites, mining locations, and facilities we or our predecessors currently or previously owned, operated or were used by us or our subsidiaries, or their predecessors, certain of which are on the United

States Environmental Protection Agency's ("EPA") Superfund National Priorities List or similar state lists. These proceedings seek cleanup costs, damages for personal injury or property damage and/or damages for injury to natural resources. Certain of these proceedings involve claims for substantial amounts. Although we may be jointly and severally liable for these costs, in most cases we are only one of a number of PRPs who may also be jointly and severally liable. In addition, we are a party to a number of personal injury lawsuits filed in various jurisdictions alleging claims related to environmental conditions alleged to have resulted from our operations.

Environmental obligations are difficult to assess and estimate for numerous reasons including:

- complexity and differing interpretations of governmental regulations;
- number of PRPs and their ability or willingness to fund such allocation of costs;
- financial capabilities of the PRPs and the allocation of costs among them;
- solvency of other PRPs;
- multiplicity of possible solutions; and
- number of years of investigatory, remedial and monitoring activity required.

In addition, the imposition of more stringent standards or requirements under environmental laws or regulations, new developments or changes regarding site cleanup costs or allocation of costs among PRPs, solvency of other PRPs, the results of future testing and analysis undertaken with respect to certain sites or a determination that we are potentially responsible for the release of hazardous substances at other sites, could cause our expenditures to exceed our current estimates. Because we may be jointly and severally liable for the total remediation cost at certain sites, the amount for which we are ultimately liable for may exceed our accruals due to, among other things, the reallocation of costs among PRPs or the insolvency of one or more PRPs. We cannot assure you that actual costs will not exceed accrued amounts or the upper end of the range for sites for which estimates have been made, and we cannot assure you that costs will not be incurred for sites where no estimates presently can be made. Further, additional environmental matters may arise in the future. If we were to incur any future liability, this could have a material adverse effect on our consolidated financial position, results of operations and liquidity.

We record liabilities related to environmental remediation obligations when estimated future expenditures are probable and reasonably estimable. We adjust our environmental accruals as further information becomes available to us or circumstances change. We generally do not discount estimated future expenditures to their present value due to the uncertainty of the timing of the pay out. We recognize recoveries of remediation costs from other parties, if any, as assets when their receipt is deemed probable. At December 31, 2008, we had no receivables for recoveries.

We do not know and cannot estimate the exact time frame over which we will make payments for our accrued environmental costs. The timing of payments depends upon a number of factors including the timing of the actual remediation process; which in turn depends on factors outside of our control. At each balance sheet date, we estimate the amount of our accrued environmental costs we expect to pay within the next twelve months, and we classify this estimate as a current liability. We classify the remaining accrued environmental costs as a noncurrent liability.

Changes in our accrued environmental costs during the past three years are presented in the table below.

	<u>Years ended December 31,</u>		
	<u>2006</u>	<u>2007</u>	<u>2008</u>
	(In millions)		
Balance at the beginning of the year	\$ 65.7	\$ 59.7	\$ 55.7
Additions charged to expense, net	4.0	4.4	6.5
Payments, net	<u>(10.0)</u>	<u>(8.4)</u>	<u>(9.3)</u>
Balance at the end of the year	<u>\$ 59.7</u>	<u>\$ 55.7</u>	<u>\$ 52.9</u>
Amounts recognized in our Consolidated Balance Sheet at the end of the year:			
Current liabilities	\$ 13.6	\$ 15.4	\$ 11.6
Noncurrent liabilities	<u>46.1</u>	<u>40.3</u>	<u>41.3</u>
Total	<u>\$ 59.7</u>	<u>\$ 55.7</u>	<u>\$ 52.9</u>

NL - On a quarterly basis, we evaluate the potential range of our liability at sites where NL, its present or former subsidiaries have been named as a PRP or defendant. At December 31, 2008, we accrued approximately \$50 million for those environmental matters related to NL which we believe are reasonably estimable. We believe that it is not possible to estimate the range of costs for certain sites. The upper end of the range of reasonably possible costs to us for sites for which we believe it is currently possible to estimate costs is approximately \$76 million, including the amount currently accrued. We have not discounted these estimates to present value.

At December 31, 2008, there were approximately 20 sites for which we are not currently able to estimate a range of costs. For these sites, generally the investigation is in the early stages, and we are unable to determine whether or not NL actually had any association with the site, the nature of our responsibility, if any, for the contamination at the site and the extent of contamination at the site. The timing and availability of information on these sites is dependent on events outside of our control, such as when the party alleging liability provides information to us. At certain of these previously inactive sites, we have received general and special notices of liability from the EPA alleging that we, along with other PRPs, are liable for past and future costs of remediating environmental contamination allegedly caused by former operations conducted at the sites. These notifications may assert that NL, along with other PRPs, are liable for past clean-up costs that could be material to us if we are ultimately found liable.

Tremont - Prior to 2005, Tremont, another of our wholly-owned subsidiaries, entered into a voluntary settlement agreement with the Arkansas Department of Environmental Quality and certain other PRPs pursuant to which Tremont and the other PRPs would undertake certain investigatory and interim remedial activities at a former mining site partly operated by NL located in Hot Springs County, Arkansas. Tremont had entered into an agreement with Halliburton Energy Services, Inc. ("Halliburton"), another PRP for this site, which provides for, among other things, the interim sharing of remediation costs associated with the site pending a final allocation of costs through an agreed-upon procedure in arbitration, as further discussed below.

On December 9, 2005, Halliburton and DII Industries, LLC, another PRP of this site, filed suit in the United States District Court for the Southern District of Texas, Houston Division, Case No. H-05-4160, against NL, Tremont and certain of its subsidiaries, M-I, L.L.C., Milwhite, Inc. and Georgia-Pacific Corporation seeking:

- to recover response and remediation costs incurred at the site;
- a declaration of the parties' liability for response and remediation costs incurred at the site;
- a declaration of the parties' liability for response and remediation costs to be incurred in the future at the site; and
- a declaration regarding the obligation of Tremont to indemnify Halliburton and DII for costs and expenses attributable to the site.

On December 27, 2005, a subsidiary of Tremont filed suit in the United States District Court for the Western District of Arkansas, Hot Springs Division, Case No. 05-6089, against Georgia-Pacific, seeking to recover response costs it has incurred and will incur at the site. Subsequently, plaintiffs in the *Houston* litigation agreed to stay that litigation by entering into an amendment with NL, Tremont and its affiliates to the arbitration agreement previously agreed upon for resolving the allocation of costs at the site. The Tremont subsidiary subsequently also agreed with Georgia Pacific to stay the *Arkansas* litigation, and subsequently that matter was consolidated with the *Houston* litigation, where the court agreed to stay the plaintiffs' claims against Tremont and its subsidiaries, but denied Tremont's motions to dismiss and to stay the claims made by M-I, Milwhite and Georgia Pacific.

In June and September 2007, the arbitration panel chosen by the parties to address the issues in the *Houston* litigation discussed above returned decisions favorable to NL, Tremont and its affiliates. Among other things, the panel found that Halliburton and DII are obligated to indemnify Tremont and its affiliates (including NL) against all costs and expenses, including attorney fees, associated with any environmental remediation at the site and other sites arising out of NL's former petroleum services business, and ordered Halliburton to pay Tremont approximately \$10.0 million in cash in recovery of past investigation and remediation costs and legal expenses incurred by Tremont related to the site, plus any future remediation and legal expenses incurred after specified dates, together with post-judgment interest accruing after September 1, 2007. In October 2007, Tremont filed a motion with the court in the *Houston* litigation to confirm the arbitration panel's decisions, and Halliburton and DII filed a motion to vacate such decisions. A confirmation hearing was held in November 2007, and in March 2008 the court upheld and confirmed the arbitration panel's decisions. In April 2008, Halliburton and DII filed a notice of their appeal of the court's opinion confirming the arbitration awards to the United States Court of Appeals for the Fifth Circuit. In July 2008, the trial court issued a final judgment pursuant to its March 2008 confirmation, and required that Halliburton and DII post a supersedeas bond in the amount of \$14.3 million during the period of the appeal in order to stay enforcement of the monetary award in the judgment. The nonmonetary portion of the judgment has not been stayed. Also in July 2008, Halliburton and DII filed a motion with the trial court for a new trial or to alter or amend its judgment, and the court subsequently denied such motion. Halliburton and DII filed a Motion for Relief from the Court's Confirmation Order and Partial Final Judgment pursuant to Fed.R.Civ.P.60(b) claiming that essential documents had been wrongfully withheld from the arbitration panel. Subsequently the Court of Appeals for the Fifth Circuit affirmed the lower court ruling and remanded the Rule 60(b) motion back to the trial court. In February 2009, the court held a hearing on the motion. Tremont has received payment from Halliburton of \$11.8 million as partial payment of the monetary judgment against it subject to the outcome of the Rule 60(b) hearing by the court.

Tremont and its affiliates (including NL) have also filed counterclaims in the Houston litigation against Halliburton and DII for other similar remediation costs associated with NL and Tremont's former petroleum services sites which the panel also found were the obligations of Halliburton and DII. At the September 26, 2008 hearing the trial court judge agreed to sever these claims from Case No. 05-6089 and consolidate those claims into a Civil Action Case No. H-08-1063 also pending with the court. Due to the uncertain nature of the on-going legal proceedings we have not accrued a receivable at December 31, 2008 for the amounts awarded. Pending a final confirmation of the arbitration panel's decisions, Tremont has accrued for this site based upon the agreed-upon interim cost sharing allocation. Tremont has a nominal amount accrued at December 31, 2008 for the environmental remediation.

Other - We have also accrued approximately \$2.8 million at December 31, 2008 for other environmental cleanup matters. This accrual is near the upper end of the range of our estimate of reasonably possible costs for such matters.

Insurance coverage claims

We are involved in certain legal proceedings with a number of our former insurance carriers regarding the nature and extent of the carriers' obligations to us under insurance policies with respect to certain lead pigment and asbestos lawsuits. The issue of whether insurance coverage for defense costs or indemnity or both will be found to exist for our lead pigment and asbestos litigation depends upon a variety of factors, and we cannot assure you that such insurance coverage will be available. We have not considered any potential insurance recoveries for lead pigment or asbestos litigation matters in determining related accruals. We recognize insurance recoveries in income only when receipt of the recovery is probable and we are able to reasonably estimate the amount of the recovery.

We have agreements with two former insurance carriers pursuant to which the carriers reimburse us for a portion of our lead pigment litigation defense costs, and one such carrier reimburses us for a portion of our asbestos litigation defense costs. We are not able to determine how much we will ultimately recover from these carriers for past defense costs incurred by us, because of certain issues that arise regarding which defense costs qualify for reimbursement. While we continue to seek additional insurance recoveries, we do not know if we will be successful in obtaining reimbursement for either defense costs or indemnity. We have not considered any additional potential insurance recoveries in determining accruals for lead pigment or asbestos litigation matters.

In October 2005 NL was served with a complaint in *OneBeacon American Insurance Company v. NL Industries, Inc., et al.* (Supreme Court of the State of New York, County of New York, Index No. 603429-05). The plaintiff, a former insurance carrier, seeks a declaratory judgment of its obligations to us under insurance policies issued to us by the plaintiff's predecessor with respect to certain lead pigment lawsuits filed against us. In March 2006, the trial court denied our motion to dismiss. In April 2006, we filed a notice of appeal of the trial court's ruling, and in September 2007, the Supreme Court - Appellate Division (First Department) reversed and ordered that the OneBeacon complaint be dismissed. The Appellate Division did not dismiss the counterclaims and cross claims.

In February 2006, NL was served with a complaint in *Certain Underwriters at Lloyds, London v. Millennium Holdings LLC et al.* (Supreme Court of the State of New York, County of New York, Index No. 06/60026). The plaintiff, a former insurance carrier of ours, seeks a declaratory judgment of its obligations to us under insurance policies issued to us by the plaintiff with respect to certain lead pigment lawsuits.

In December 2008, NL reached partial settlements with the plaintiffs in the two cases discussed above, pursuant to which the two former insurance carriers agreed to pay us an aggregate of approximately \$7.2 million in settlement of certain counter-claims related to past lead pigment and asbestos defense costs. We received these funds from the carriers in January 2009. In connection with these partial settlements, we agreed to dismiss the case captioned *NL Industries, Inc. v. OneBeacon America Insurance Company, et al.* (District Court for Dallas County, Texas, Case No. 05-11347), and in January 2009 we filed a notice of non-suit without prejudice in that matter. The remaining claims in the New York cases are proceeding in the trial court. See Note 5.

Other litigation

NL - In June 2005, we received notices from the three minority shareholders of EMS indicating they were each exercising their right, which became exercisable on June 1, 2005, to require EMS to purchase their preferred shares in EMS as of June 30, 2005 for a formula-determined amount as provided in EMS' certificate of incorporation. In accordance with the certificate of incorporation, we made a determination in good faith of the amount payable to the three former minority shareholders to purchase their shares of EMS stock, which amount may be subject to review by a third party. In June 2005, we set aside funds as payment for the shares of EMS, but as of December 31, 2008 the former minority shareholders have not tendered their shares. Therefore, the liability owed to these former minority shareholders has not been extinguished for financial reporting purposes as of December 31, 2008 and remains recognized as a current liability in our Consolidated Financial Statements. We have similarly classified the funds which have been set aside in restricted cash and cash equivalents.

In May 2007, we filed a complaint in Texas state court (*Contran Corporation, et al. v. Terry S. Casey, et al.*, Case No. 07-04855, 192nd Judicial District Court, Dallas County, Texas) in which we alleged negligence, conversion, and breach of contract against a former service provider of ours who was also a former minority shareholder of EMS. In February 2008, two other former minority shareholders of EMS filed counterclaims, a third-party petition and petition in intervention, seeking damages related to their former ownership in EMS. Our original claims were removed to arbitration, and the case is now captioned *Industrial Recovery Capital Holdings Co. et al. v. Harold C. Simmons et al.*, Case No. 08-02589, District Court, Dallas County, Texas. The defendants are NL, Contran, us and certain of NL's and EMS's current or former officers or directors. The plaintiffs claim that, in preparing the valuation of the former minority shareholders' preferred shares for purchase by EMS, defendants have committed fraud, breach of fiduciary duty, civil conspiracy, breach of contract and tortious interference with economic relations. We believe that these claims are without merit and have denied all liability therefor. NL and EMS have also filed counterclaims against the former minority shareholders relating to the formation and management of EMS. Trial is scheduled for July 2009.

CompX - On February 10, 2009, a complaint was filed with the U.S. International Trade Commission ("ITC") by Humanscale Corporation requesting that the ITC commence an investigation pursuant to Section 337 of the Tariff Act of 1930 to determine allegations concerning the unlawful importation of certain adjustable keyboard related products into the U.S. by our Canadian subsidiary. The products are alleged to infringe certain claims under a U.S. patent held by Humanscale. The complaint seeks as relief the barring of future imports of the products into the U.S. until the expiration of the related patent in March 2011. Additionally, on February 13, 2009, a complaint for patent infringement was filed in the United States District Court, Eastern District of Virginia, by Humanscale against us and our Canadian subsidiary. We have not been served in this matter as of the filing of our annual report

on Form 10-K, however, CompX and Waterloo Furniture Components Limited, the Canadian subsidiary, deny the allegations of infringement noted in this complaint. We intend to deny the infringement before the ITC and seek to dismiss the complaint.

We have been named as a defendant in various lawsuits in several jurisdictions, alleging personal injuries as a result of occupational exposure primarily to products manufactured by some of our former operations containing asbestos, silica and/or mixed dust. Approximately 465 of these types of cases remain pending, involving a total of approximately 5,400 plaintiffs. In addition, the claims of approximately 4,400 former plaintiffs have been administratively dismissed or placed on the inactive docket in Ohio state courts. We do not expect these claims will be re-opened unless the plaintiffs meet the courts' medical criteria for asbestos-related claims. We have not accrued any amounts for this litigation because of the uncertainty of liability and inability to reasonably estimate the liability, if any. To date, we have not been adjudicated liable in any of these matters. Based on information available to us, including:

- facts concerning our historical operations,
- the rate of new claims,
- the number of claims from which we have been dismissed, and
- and our prior experience in the defense of these matters,

we believe that the range of reasonably possible outcomes of these matters will be consistent with our historical costs (which are not material). Furthermore, we do not expect any reasonably possible outcome would involve amounts material to our consolidated financial position, results of operations or liquidity. We have sought and will continue to vigorously seek dismissal and/or a finding of no liability from each claim. In addition, from time to time, we have received notices regarding asbestos or silica claims purporting to be brought against former subsidiaries, including notices provided to insurers with which we have entered into settlements extinguishing certain insurance policies. These insurers may seek indemnification from us.

In addition to the litigation described above, we and our affiliates are involved in various other environmental, contractual, product liability, patent (or intellectual property), employment and other claims and disputes incidental to our present and former businesses. In certain cases, we have insurance coverage for these items, although we do not expect any additional material insurance coverage for our environmental claims.

We currently believe that the disposition of all of these various other claims and disputes, individually or in the aggregate, should not have a material adverse effect on our consolidated financial position, results of operations or liquidity beyond the accruals already provided.

Other matters

Concentrations of credit risk. Sales of TiO₂ accounted for approximately 90% of our Chemicals sales during each of the past three years. TiO₂ is generally sold to the paint, plastics and paper industries, which are generally considered "quality-of-life" markets whose demand for TiO₂ is influenced by the relative economic well-being of the various geographic regions. TiO₂ is sold to over 4,000 customers and the ten largest customers accounted for approximately 27% of chemicals sales. No single customer accounted for more than 10% of sales in 2008. In each of the past three years, approximately one-half of our TiO₂ sales volumes were to Europe with about 34% attributable to North America in 2008.

We sell our Component Products primarily to original equipment manufacturers in North America. In 2008, the ten largest customers accounted for approximately 35% of component products sales. No single customer accounted for more than 10% of sales in 2008.

At December 31, 2008, consolidated cash, cash equivalents and restricted cash includes approximately \$5.1 million on deposit at a single U.S. bank (in 2007 the amount was \$26.4 million).

Operating leases. Our principal Chemicals Segment operating subsidiary in Germany, Kronos Titan GmbH, leases the land under its Leverkusen TiO₂ production facility pursuant to a lease with Bayer AG that expires in 2050. We own the Leverkusen facility itself, which represents approximately one-third of our current TiO₂ production capacity. This facility is located within Bayer's extensive manufacturing complex. We periodically establish the amount of rent for the land lease associated with our Leverkusen facility by agreement with Bayer for periods of at least two years at a time. The lease agreement provides for no formula, index or other mechanism to determine changes in the rent for the land lease; rather, any change in the rent is subject solely to periodic negotiation between Bayer and us. We recognize any change in the rent based on negotiations as part of lease expense starting from the time such change is agreed upon by both of us, as any such change in the rent is deemed "contingent rentals" under GAAP. Under a separate supplies and services agreement expiring in 2011, Bayer provides some raw materials, including chlorine, auxiliary and operating materials, utilities and services necessary for us to operate our Leverkusen facility.

We also lease various other manufacturing facilities and equipment. Some of the leases contain purchase and/or various term renewal options at fair market and fair rental values, respectively. In most cases we expect that, in the normal course of business, such leases will be renewed or replaced by other leases. Rent expense approximated \$12 million in each of 2006, 2007 and 2008. At December 31, 2008, our future minimum payments under noncancellable operating leases having an initial or remaining term of more than one year were as follows:

<u>Years ending December 31,</u>	<u>Amount</u> (In millions)
2009	\$5.9
2010	4.3
2011	2.9
2012	2.2
2013	1.7
2014 and thereafter	<u>18.9</u>
Total ⁽¹⁾	<u>\$35.9</u>

⁽¹⁾ Approximately \$22 million relates to the Leverkusen facility lease. The minimum commitment amounts for the lease included in the table above for each year through the 2050 expiration of the lease are based upon the current annual rental rate as of December 31, 2008.

Long-term contracts. Our Chemicals Segment has long-term supply contracts that provide for our TiO₂ feedstock requirements through 2011. The agreements require us to purchase certain minimum quantities of feedstock with minimum purchase commitments aggregating approximately \$505 million at December 31, 2008. In addition, our Chemicals Segment has other long-term supply and service contracts that provide for various raw materials and services through 2050. These agreements require us to purchase certain minimum quantities or services with minimum purchase commitments aggregating approximately \$113 million at December 31, 2008. At December 31, 2008 our Waste Management Segment had aggregate commitments related to new byproduct disposal facilities totaling approximately \$24 million.

Income taxes. Prior to 2006, NL made certain other pro-rata distributions to its stockholders in the form of shares of Kronos common stock. All of NL's distributions of Kronos common stock were taxable to NL and NL recognized a taxable gain equal to the difference between the fair market value of the Kronos shares distributed on the various dates of distribution and NL's adjusted tax basis in the shares at the dates of distribution. NL transferred shares of Kronos common stock to us in satisfaction of the tax liability related to NL's gain on the transfer or distribution of these shares of Kronos common stock and the tax liability generated from the use of Kronos shares to settle the tax liability. To date, we have not paid the liability to Contran because Contran has not paid the liability to the applicable tax authority. The income tax liability will become payable to Contran, and by Contran to the applicable tax authority, when the shares of Kronos transferred or distributed by NL to us are sold or otherwise transferred outside the Contran Tax Group or in the event of certain restructuring transactions involving us. We have recognized deferred income taxes for our investment in Kronos common stock.

We and Contran have agreed to a policy providing for the allocation of tax liabilities and tax payments as described in Note 1. Under applicable law, we, as well as every other member of the Contran Tax Group, are each jointly and severally liable for the aggregate federal income tax liability of Contran and the other companies included in the Contran Tax Group for all periods in which we are included in the Contran Tax Group. Contran has agreed, however, to indemnify us for any liability for income taxes of the Contran Tax Group in excess of our tax liability previously computed and paid by us in accordance with the tax allocation policy.

Note 18 - Recent accounting pronouncements:

Fair Value Measurements - In September 2006, the Financial Accounting Standards Board ("FASB") issued SFAS No. 157, *Fair Value Measurements*, which will become effective for us on January 1, 2008. SFAS No. 157 generally provides a consistent, single fair value definition and measurement techniques for GAAP pronouncements. SFAS No. 157 also establishes a fair value hierarchy for different measurement techniques based on the objective nature of the inputs in various valuation methods. In February 2008, the FASB issued FSP No. FAS 157-2, *Effective Date of FASB Statement No. 157* which delays the provisions of SFAS No. 157 until January 1, 2009 for all nonfinancial assets and nonfinancial liabilities, except those that are recognized or disclosed at fair value in the financial statements on a recurring basis (at least annually). All of our fair value measurements are in compliance with SFAS No. 157, on a prospective basis, beginning in the first quarter of 2008, except for non financial assets and liabilities, which we will be required to be in compliance with SFAS No. 157 prospectively beginning in the first quarter of 2009. In addition, we have expanded our disclosures regarding the valuation methods and level of inputs we utilize beginning in the first quarter of 2008, except for non-financial assets and liabilities, which will require disclosure in the first quarter of 2009. The adoption of this standard did not have a material effect on our Consolidated Financial Statements.

Fair Value Option - In the first quarter of 2007 the FASB issued SFAS No. 159, *The Fair Value Option for Financial Assets and Financial Liabilities*. SFAS No. 159 permits companies to choose, at specified election dates, to measure eligible items at fair value, with unrealized gains and losses included in the determination of net income. The decision to elect the fair value option is generally applied on an instrument-by-instrument basis, is irrevocable unless a new election date occurs, and is applied to the entire instrument and not only to specified risks or cash flows or a portion of the instrument. Items eligible for the fair value option include recognized financial assets and liabilities, other than an investment in a consolidated

subsidiary, defined benefit pension plans, postretirement benefit plans, leases and financial instruments classified in equity. An investment accounted for by the equity method is an eligible item. The specified election dates include the date the company first recognizes the eligible item, the date the company enters into an eligible commitment, the date an investment first becomes eligible to be accounted for by the equity method and the date SFAS No. 159 first becomes effective for the company. SFAS No. 159 became effective for us on January 1, 2008. We did not elect to measure any eligible items at fair value in accordance with this new standard either at the date we adopted the new standard or subsequently during 2008; therefore the adoption of this standard did not have a material effect on our Consolidated Financial Statements.

Noncontrolling Interest - In December 2007 the FASB issued SFAS No. 160, *Noncontrolling Interests in Consolidated Financial Statements, an Amendment of ARB No. 51*. SFAS No. 160 establishes a single method of accounting for changes in a parent's ownership interest in a subsidiary that do not result in deconsolidation. On a prospective basis any changes in ownership will be accounted for as equity transactions with no gain or loss recognized on the transactions unless there is a change in control; under existing GAAP such changes in ownership generally result either in the recognition of additional goodwill (for an increase in ownership) or a gain or loss included in the determination of net income (for a decrease in ownership). The statement standardizes the presentation of noncontrolling interest as a component of equity on the balance sheet and on a net income basis in the statement of operations. This Statement also requires expanded disclosures in the consolidated financial statements that clearly identify and distinguish between the interests of the parent and the interests of the noncontrolling owners of a subsidiary. Those expanded disclosures include a reconciliation of the beginning and ending balances of the equity attributable to the parent and the noncontrolling owners and a schedule showing the effects of changes in a parent's ownership interest in a subsidiary on the equity attributable to the parent. This statement will be effective for us on a prospective basis in the first quarter of 2009. We will be required to reclassify our balance sheet and statement of operations to conform to the new presentation requirements and to include the expanded disclosures at that time. Because the new method of accounting for changes in ownership applies on a prospective basis, we are unable to predict the impact of the statement on our Consolidated Financial Statements. However, to the extent we have subsidiaries that are not wholly owned at the date of adoption, any subsequent increase in ownership of such subsidiaries for an amount of consideration that exceeds the then-carrying value of the noncontrolling interest related to the increased ownership would result in a reduction in the amount of equity attributable to our shareholders.

Business Combinations - Also in December 2007 the FASB issued SFAS No. 141 (revised 2007), *Business Combinations*, which applies to us prospectively for business combinations that close in 2009 and beyond. The statement expands the definition of a business combination to include more transactions including some asset purchases and requires an acquirer to recognize assets acquired, liabilities assumed and any noncontrolling interest in the acquiree at the acquisition date at fair value as of that date with limited exceptions. The statement also requires that acquisition costs be expensed as incurred and restructuring costs that are not a liability of the acquiree at the date of the acquisition be recognized in accordance with SFAS No. 146, *Accounting for Costs Associated with Exit or Disposal Activities*. Due to the unpredictable nature of business combinations and the prospective application of this statement we are unable to predict the impact of the statement on our Consolidated Financial Statements.

Derivative Disclosures - In March 2008 the FASB issued SFAS No. 161, *Disclosures about Derivative Instruments and Hedging Activities, an Amendment of FASB Statement No. 133*. SFAS No. 161 changes the disclosure requirements for derivative instruments and hedging activities to provide enhanced disclosures about how and why we use derivative instruments, how derivative instruments and related hedged items are accounted for under SFAS No. 133 and how derivative instruments and related hedged items affect our financial position and performance and cash flows. This statement will become effective for us in the first quarter of 2009. We periodically use currency forward contracts to manage a portion of our foreign currency exchange rate market risk associated with trade receivables or future sales. The contracts we have outstanding at December 31, 2008 are marked to market at each balance sheet date and are not accounted for under hedge accounting. Because our prior disclosures regarding these forward contracts have substantially met all of the applicable disclosure requirements of the new standard, we do not believe the enhanced disclosure requirements of this new standard will have a significant effect on our Consolidated Financial Statements.

Uncertain Tax Positions - In the second quarter of 2006 the FASB issued FIN No. 48, *Accounting for Uncertain Tax Positions*, which we adopted on January 1, 2007. FIN No. 48 clarifies when and how much of a benefit we can recognize in our consolidated financial statements for certain positions taken in our income tax returns under Statement of Financial Accounting Standards No. 109, *Accounting for Income Taxes*, and enhances the disclosure requirements for our income tax policies and reserves. Among other things, FIN No. 48 prohibits us from recognizing the benefits of a tax position unless we believe it is more-likely-than-not our position will prevail with the applicable tax authorities and limits the amount of the benefit to the largest amount for which we believe the likelihood of realization is greater than 50%. FIN No. 48 also requires companies to accrue penalties and interest on the difference between tax positions taken on their tax returns and the amount of benefit recognized for financial reporting purposes under the new standard. We are required to classify any future reserves for uncertain tax positions in a separate current or noncurrent liability, depending on the nature of the tax position.

Upon adoption of FIN No. 48 on January 1, 2007, we increased our existing reserve for uncertain tax positions, which we previously classified as part of our deferred income taxes, from \$55.3 million to \$56.9 million and accounted for such \$1.6 million increase as a decrease to retained earnings in accordance with the transition provisions of the standard. See Notes 1 and 12.

The following table shows the changes in the amount of our uncertain tax positions (exclusive of the effect of interest and penalties) during 2007 and 2008:

	<u>Years ended December 31,</u>	
	<u>2007</u>	<u>2008</u>
	(In millions)	
Unrecognized tax benefits:		
Amount beginning of period	\$ -	\$42.4
Amount at adoption of FIN No. 48	39.5	-
Net increase (decrease):		
Tax positions taken in prior periods	(1.8)	(2.1)
Tax positions taken in current period	10.8	11.8
Settlements with taxing authorities -		
cash paid	(.6)	(.1)
Lapse of applicable statute of limitations	(6.5)	(4.1)
Foreign currency translation	<u>1.0</u>	<u>(1.3)</u>
Amount at end of period	<u>\$42.4</u>	<u>\$46.6</u>

If our uncertain tax positions were recognized, a benefit of \$49.0 million and of \$41.8 million at December 31, 2007 and 2008, respectively, would affect our effective income tax rate. We currently estimate that our unrecognized tax benefits will decrease by approximately \$3.7 million during the next twelve months due to the reversal of certain timing differences and the resolution of certain examination and filing procedures related to one or more of our subsidiaries.

We file income tax returns in various U.S. federal, state and local jurisdictions. We also file income tax returns in various foreign jurisdictions, principally in Germany, Canada, Taiwan, Belgium and Norway. Our domestic income tax returns prior to 2005 are generally considered closed to examination by applicable tax authorities. Our foreign income tax returns are generally considered closed to examination for years prior to: 2003 for Canada, Belgium and Taiwan; 2004 for Germany and 1999 for Norway.

We accrue interest and penalties on our uncertain tax positions as a component of our provision for income taxes. We accrued \$1.2 million of interest and penalties during 2008, and at December 31, 2007 and 2008 we had \$5.1 million and \$4.0 million accrued for interest and an immaterial amount accrued for penalties for our uncertain tax positions.

Benefit Plan Asset Disclosures - During the fourth quarter of 2008, the FASB issued FSP SFAS 132 (R)-1, *Employers' Disclosures about Postretirement Benefit Plan Assets*, which amends SFAS No. 87, 88 and 106 to require expanded disclosures about employers' pension plan assets. FSP 132 (R)-1 will be effective for us beginning with our 2009 annual report, and we will provide the expanded disclosures about our pension plan assets at that time.

Note 19 - Financial instruments:

We adopted SFAS No. 157 effective January 1, 2008 for financial assets and liabilities measured on a recurring basis. SFAS No. 157 applies to all financial assets and financial liabilities that are being measured and reported on a fair value basis. SFAS No. 157 establishes a framework for measuring fair value and expands disclosure about fair value measurements. The statement requires fair value measurements to be classified and disclosed in one of the following three categories, see Notes 1 and 18.

There was no impact for the adoption of SFAS No. 157 to the Consolidated Financial Statements. The following table summarizes the valuation of our short-term investments and financial instruments by the above SFAS No. 157 categories as of December 31, 2008:

	<u>Fair Value Measurements at December 31, 2008</u>			
	<u>Total</u>	<u>Quoted</u>	<u>Significant</u>	
		<u>Prices in</u>	<u>Other</u>	<u>Significant</u>
		<u>Active</u>	<u>Observable</u>	<u>Unobservable</u>
	<u>Markets</u>	<u>Inputs</u>	<u>Inputs</u>	
	<u>(Level 1)</u>	<u>(Level 2)</u>	<u>(Level 3)</u>	
	<u>(in millions)</u>			
Marketable securities:				
Current	\$ 8.8	\$ -	\$ 8.8	\$ -
Noncurrent	275.5	25.1	.4	250.0
Currency forward contracts	(1.6)	(1.6)	-	-

See Note 4 for information on how we determine fair value of our marketable securities.

We periodically use currency forward contracts to manage a portion of foreign currency exchange rate market risk associated with trade receivables, or similar exchange rate risk associated with future sales, denominated in a currency other than the holder's functional currency. These contracts generally relate to our Chemicals and Component Products operations. We have not entered into these contracts for trading or speculative purposes in the past, nor do we currently anticipate entering into such contracts for trading or speculative purposes in the future. Some of the currency forward contracts we enter into meet the criteria for hedge accounting under GAAP and are designated as cash flow hedges. For these currency forward contracts, gains and losses representing the effective portion of our hedges are deferred as a component of accumulated other comprehensive income, and are subsequently recognized in earnings at the time the hedged item affects earnings. For the currency forward contracts we enter into which do not meet the criteria for hedge accounting, we mark-to-market the estimated fair value of such contracts at each balance sheet date, with any resulting gain or loss recognized in income currently as part of net currency transactions. The fair value of the currency forward contracts is determined using Level 1 inputs as defined in SFAS No. 157 based on the foreign currency spot forward rates quoted by banks or foreign currency dealers.

At December 31, 2008 we held the following series of short-term forward exchange contracts.

- Our Component Products Segment entered into a series of short-term forward exchange contracts maturing through June 2009 to exchange an aggregate of \$7.5 million for an equivalent value of Canadian dollars at an exchange rate of Cdn. \$1.25 to \$1.26 per U.S. dollar. At December 31, 2008, the actual exchange rate was Cdn. \$1.22 per U.S. dollar.
- Our Chemicals Segment entered into an aggregate of \$30.0 million for an equivalent value of Canadian dollars at exchange rates ranging from Cdn. \$1.25 to Cdn. \$1.26 per U.S. dollar. These contracts with U.S. Bank mature from January 2009 through December 2009 at a rate of \$2.5 million per month. At December 31, 2008, the actual exchange rate was Cdn. \$1.22 per U.S. dollar.

- Our Chemicals Segment entered an aggregate \$57 million for an equivalent value of Norwegian kroner at exchange rates ranging from kroner 6.91 to kroner 7.18. These contracts with DnB Nor Bank ASA mature from January 2009 through December 2009 at a rate of .5 million to \$2.5 million per month. At December 31, 2008, the actual exchange rate was kroner 7.0 per U.S. dollar.
- Our Chemicals Segment entered an aggregate euro 16.4 million for an equivalent value of Norwegian Kroner at exchange rates ranging from kroner 8.64 to kroner 9.23. These contracts with DnB Nor Bank ASA mature from January 2009 through December 2009 at a rate of euro .5 million to euro .7 million per month. At December 31, 2008, the actual exchange rate was kroner 9.7 per euro.

The estimated fair value of such foreign currency forward contracts at December 31, 2008 was a \$1.6 million net liability, which \$1.3 million is recognized as part of prepaid expenses and \$2.9 million is recognized as part of accounts payable and accrued liabilities in our Consolidated Balance Sheet and a corresponding \$1.6 million foreign currency transaction loss in our Consolidated Statement of Operations.

We had no forward contracts outstanding at December 31, 2007.

The following table presents the financial instruments that are not carried at fair value but which require fair value disclosure as December 31, 2007 and 2008:

	December 31,			
	2007		2008	
	<u>Carrying amount</u>	<u>Fair value</u>	<u>Carrying amount</u>	<u>Fair value</u>
	(In millions)			
Cash, cash equivalents and restricted cash equivalents	\$145.6	\$ 145.6	\$ 46.4	\$ 46.4
Promissory note receivable	-	-	15.0	15.0
Long-term debt (excluding capitalized leases):				
Publicly-traded fixed rate debt -				
KII Senior Secured Notes	\$585.5	\$ 507.7	\$560.0	\$ 129.4
Snake River Sugar Company fixed rate loans	250.0	250.0	250.0	250.0
CompX variable rate promissory note	50.0	50.0	43.0	43.0
Variable rate debt	15.4	15.4	63.2	63.2
Other fixed-rate debt	.4	.4	.9	.9
Minority interest in:				
NL common stock	\$ 55.6	\$ 93.1	\$ 45.8	\$ 110.0
Kronos common stock	20.5	42.7	15.6	27.6
CompX common stock	14.4	25.2	11.9	8.5
Valhi common stockholders' equity	\$618.4	\$1,823.6	\$468.8	\$1,223.4

The fair value of our publicly-traded marketable securities, minority interest in NL Industries, Kronos and CompX and our common stockholders' equity are all based upon quoted market prices, Level 1 inputs as defined in SFAS No. 157, *Fair Value Measurements*, at each balance sheet date. The fair value of our 6.5% Notes are also based on quoted market prices at each balance sheet date; however, these quoted market prices represent Level 2 inputs as defined by SFAS No. 157 because the markets in which the Notes trade are not active. At December 31, 2007 and 2008, the estimated market price of the 6.5% Notes was approximately euro 860 and euro 230, respectively, per euro 1,000 principal amount. The fair value of our fixed-rate nonrecourse loans from Snake River Sugar Company is based upon the \$250 million redemption price of our investment in the Amalgamated Sugar Company LLC, which collateralizes the nonrecourse loans, (this is a Level 3 input as defined in SFAS No. 157). Fair values of variable interest rate note receivable and debt and other fixed-rate debt are deemed to approximate book value. Due to their near-term maturities, the carrying amounts of accounts receivable and accounts payable are considered equivalent to fair value. See Notes 4 and 9.

Note 20 - Earnings per share:

Basic earnings per share of common stock is based upon the weighted average number of our common shares actually outstanding during each period. Diluted earnings per share of common stock includes the impact of our outstanding dilutive stock options as well as the dilutive effect, if any, of diluted earnings per share reported by Kronos, NL, CompX or TIMET.

	<u>Years ended December 31,</u>		
	<u>2006</u>	<u>2007</u>	<u>2008</u>
	(In millions, except per share data)		
Basic EPS computation:			
Numerator -			
Net income (loss)	<u>\$141.7</u>	<u>\$ (45.7)</u>	<u>\$ (.8)</u>
Denominator -			
Weighted average common shares	<u>116.1</u>	<u>114.7</u>	<u>114.4</u>
Basic EPS	<u>\$ 1.22</u>	<u>\$ (.40)</u>	<u>\$ (.01)</u>
Diluted EPS computation:			
Numerator:			
Net income (loss)	\$141.7	\$ (45.7)	\$ (.8)
Net effect of diluted earnings per share of TIMET ⁽¹⁾	<u>(2.3)</u>	<u>-</u>	<u>-</u>
Net income (loss) for diluted earnings per share	<u>\$139.4</u>	<u>\$ (45.7)</u>	<u>\$ (.8)</u>
Denominator:			
Weighted average common shares -			
Basic	116.1	114.7	114.4
Stock option conversion ⁽²⁾	<u>.4</u>	<u>-</u>	<u>-</u>
Weighted average common shares -			
Diluted	<u>116.5</u>	<u>114.7</u>	<u>114.4</u>
Diluted EPS	<u>\$ 1.20</u>	<u>\$ (.40)</u>	<u>\$ (.01)</u>

(1) The dilutive effect of dilutive earnings per share for Kronos, NL and CompX in 2006, 2007 and 2008 and for TIMET in 2007 was not significant.

(2) Stock option conversion excludes anti-dilutive shares of 267,000 during 2007 and 295,000 during 2008.

Note 21 - Quarterly results of operations (unaudited):

	Quarter ended			
	March 31	June 30	Sept. 30	Dec. 31
(In millions, except per share data)				
Year ended December 31, 2007				
Net sales	\$359.0	\$389.0	\$390.6	\$353.6
Gross margin	80.1	72.9	76.3	56.6
Operating income	32.9	26.2	24.2	7.2
Net income (loss) ⁽¹⁾	\$ 26.1	\$ (4.9)	\$ (52.7)	\$ (14.2)
Per basic share:				
Net income (loss)	\$.23	\$ (.04)	\$ (.46)	\$ (.12)
Year ended December 31, 2008				
Net sales	\$373.9	\$436.1	\$390.2	\$285.1
Gross margin	63.5	66.4	58.0	58.3
Operating income	9.6	9.8	(2.1)	18.7
Net income (loss) ⁽²⁾	\$ (5.9)	\$ (.2)	\$ (23.2)	\$ 28.5
Per basic share:				
Net income (loss)	\$ (.05)	\$ -	\$ (.20)	\$.25

⁽¹⁾ We recognized the following amounts during 2007:

- Beginning in the second quarter we no longer had equity in earnings of TIMET, see Note 3; and
- We recognized a \$87.4 million tax charge in the third quarter for a change in the German tax rates, see Note 12.

⁽²⁾ We recognized the following amounts during 2008:

- We recognized a \$10.1 million goodwill impairment charge in the third quarter, see Note 8; and
- We recognized a \$25.8 million after-tax gain in the fourth quarter for real property settlement, see Note 15.

The sum of the quarterly per share amounts may not equal the annual per share amounts due to relative changes in the weighted average number of shares used in the per share computations.

VALHI, INC. AND SUBSIDIARIES

SCHEDULE I - CONDENSED FINANCIAL INFORMATION OF REGISTRANT

Condensed Balance Sheets

(In millions)

	<u>December 31,</u>	
	<u>2007</u>	<u>2008</u>
Current assets:		
Cash and cash equivalents	\$ 18.4	\$ 1.6
Restricted cash equivalents	.4	.5
Accounts receivable	.5	.2
Receivables from subsidiaries and affiliates	-	.9
Deferred income taxes	1.6	1.7
Other	.3	.2
Total current assets	<u>21.2</u>	<u>5.1</u>
Other assets:		
Marketable securities	271.9	257.3
Investment in and advances to subsidiaries	918.0	798.2
Other assets	.3	.1
Property and equipment, net	.9	1.2
Total other assets	<u>1,191.1</u>	<u>1,056.8</u>
Total assets	<u>\$1,212.3</u>	<u>\$1,061.9</u>
Current liabilities:		
Current maturities of long-term debt	\$ -	\$ 7.3
Payables to subsidiaries and affiliates:		
Income taxes, net	1.5	2.9
Other	.7	3.0
Accounts payable and accrued liabilities	3.1	2.0
Total current liabilities	<u>5.3</u>	<u>15.2</u>
Noncurrent liabilities:		
Long-term debt - Snake River Sugar Company	250.0	250.0
Deferred income taxes	321.4	302.1
Other	17.2	25.8
Total noncurrent liabilities	<u>588.6</u>	<u>577.9</u>
Stockholders' equity	<u>618.4</u>	<u>468.8</u>
Total liabilities and stockholders' equity	<u>\$1,212.3</u>	<u>\$1,061.9</u>

The accompanying Notes are an integral part of the financial statements.

VALHI, INC. AND SUBSIDIARIES

SCHEDULE I - CONDENSED FINANCIAL INFORMATION OF REGISTRANT (CONTINUED)

Condensed Statements of Operations

(In millions)

	<u>Years ended December 31,</u>		
	<u>2006</u>	<u>2007</u>	<u>2008</u>
Revenues and other income:			
Interest and dividend income	\$ 36.0	\$ 29.2	\$ 27.0
Equity in earnings of subsidiaries and affiliates	151.6	(63.0)	2.0
Other income, net	<u>3.9</u>	<u>3.8</u>	<u>2.3</u>
Total revenues and other income	<u>191.5</u>	<u>(30.0)</u>	<u>31.3</u>
Costs and expenses:			
General and administrative	7.9	7.6	6.6
Interest	<u>24.1</u>	<u>24.1</u>	<u>24.2</u>
Total costs and expenses	<u>32.0</u>	<u>31.7</u>	<u>30.8</u>
Income (loss) before income taxes	159.5	(61.7)	.5
Provision for income taxes (benefit)	<u>17.8</u>	<u>(16.0)</u>	<u>1.3</u>
Net income (loss)	<u>\$141.7</u>	<u>\$(45.7)</u>	<u>\$ (.8)</u>

The accompanying Notes are an integral part of the financial statements.

VALHI, INC. AND SUBSIDIARIES

SCHEDULE I - CONDENSED FINANCIAL INFORMATION OF REGISTRANT (CONTINUED)

Condensed Statements of Cash Flows

(In millions)

	<u>Years ended December 31,</u>		
	<u>2006</u>	<u>2007</u>	<u>2008</u>
Cash flows from operating activities:			
Net income (loss)	\$ 141.7	\$ (45.7)	\$ (.8)
Deferred income taxes	20.7	(19.5)	(1.8)
Equity in earnings of subsidiaries and affiliates	(151.6)	63.0	(2.0)
Cash dividends from subsidiaries	87.0	49.2	51.0
Other, net	(.7)	.1	.1
Net change in assets and liabilities	<u>(.6)</u>	<u>12.8</u>	<u>8.1</u>
Net cash provided by operating activities	<u>96.5</u>	<u>59.9</u>	<u>54.6</u>
Cash flows from investing activities:			
Purchases of:			
Kronos common stock	(25.4)	-	-
TIMET common stock	(18.7)	(27.5)	-
NL common stock	(.4)	-	-
Loans to subsidiaries and affiliates:			
Loans	(12.9)	(20.1)	(32.2)
Collections	.8	-	-
Investment in other subsidiary	(2.4)	(5.3)	(3.1)
Change in restricted cash equivalents, net	-	.1	-
Other, net	<u>1.5</u>	<u>-</u>	<u>(.2)</u>
Net cash used in investing activities	<u>(57.5)</u>	<u>(52.8)</u>	<u>(35.5)</u>

VALHI, INC. AND SUBSIDIARIES

SCHEDULE I - CONDENSED FINANCIAL INFORMATION OF REGISTRANT (CONTINUED)

Condensed Statements of Cash Flows (Continued)

(In millions)

	<u>Years ended December 31,</u>		
	<u>2006</u>	<u>2007</u>	<u>2008</u>
Cash flows from financing activities:			
Indebtedness:			
Borrowings	\$ -	\$ -	\$ 47.6
Principal payments	-	-	(40.3)
Loans from affiliates:			
Borrowings	-	-	3.0
Principal payments	-	-	(.7)
Cash dividends	(48.0)	(45.6)	(45.5)
Treasury stock acquired	(43.8)	(11.1)	-
Other, net	<u>.3</u>	<u>.7</u>	<u>-</u>
Net cash used by financing activities	<u>(91.5)</u>	<u>(56.0)</u>	<u>(35.9)</u>
Cash and cash equivalents:			
Net decrease	(52.5)	(48.9)	(16.8)
Balance at beginning of year	<u>119.8</u>	<u>67.3</u>	<u>18.4</u>
Balance at end of year	<u>\$ 67.3</u>	<u>\$ 18.4</u>	<u>\$ 1.6</u>
Supplemental disclosures -			
Cash paid (received) for:			
Interest	\$ 24.7	\$ 24.0	\$ 24.1
Income taxes, net	1.3	(10.9)	(6.2)
Noncash financing activity:			
Dividend of TIMET common stock	-	897.4	-
Issuance of preferred stock in			
Settlement of tax obligation	-	667.3	-

The accompanying Notes are an integral part of the financial statements.

VALHI, INC. AND SUBSIDIARIES

SCHEDULE I - CONDENSED FINANCIAL INFORMATION OF REGISTRANT (CONTINUED)

NOTES TO CONDENSED FINANCIAL INFORMATION

December 31, 2008

Note 1 - Basis of presentation:

We have prepared the accompanying Financial Statements on a "Parent Company" basis. This means that our investments in the common stock or membership interest of our majority and wholly-owned subsidiaries, including NL Industries, Inc., Kronos Worldwide, Inc., Tremont LLC, Valcor, Inc. (which was merged into Valhi in 2007), Medite Corporation (formerly a wholly-owned subsidiary of Valcor) and Waste Control Specialists LLC, are presented on the equity method of accounting. Our Consolidated Financial Statements and the Notes thereto, which include the financial position, results of operations and cash flows of these subsidiaries, are incorporated by reference into these Parent Company Financial Statements.

Note 2 - Investment in and advances to subsidiaries:

	<u>December 31,</u>	
	<u>2007</u>	<u>2008</u>
	(In millions)	
Investment in:		
NL Industries (NYSE: NL)	\$334.7	\$284.9
Kronos Worldwide, Inc. (NYSE: KRO)	509.2	451.2
Tremont LLC	13.4	11.1
Medite	13.7	(5.9)
Waste Control Specialists LLC	<u>40.8</u>	<u>50.1</u>
Total	911.8	791.4
Noncurrent loans to Waste Control Specialists LLC	<u>6.2</u>	<u>6.8</u>
Total	<u>\$918.0</u>	<u>\$798.2</u>

	<u>Years ended December 31,</u>		
	<u>2006</u>	<u>2007</u>	<u>2008</u>
	(In millions)		

Equity in earnings of subsidiaries and affiliate

NL Industries	\$ 22.7	\$ (29.9)	\$ 19.4
Kronos Worldwide	43.4	(39.0)	4.2
Tremont LLC	86.4	16.6	(1.9)
Valcor and Medite	1.4	2.6	2.9
Waste Control Specialists LLC	(10.3)	(15.2)	(22.6)
TIMET	8.0	1.9	-
Total	<u>\$151.6</u>	<u>\$ (63.0)</u>	<u>\$ 2.0</u>

Cash dividends from subsidiaries

NL Industries	\$ 20.1	\$ 20.2	\$ 20.2
Kronos Worldwide	29.0	29.0	29.0
Tremont LLC	37.9	-	1.8
Total	<u>\$ 87.0</u>	<u>\$ 49.2</u>	<u>\$ 51.0</u>

Note 5 - Long-term debt:

Our \$250 million in loans from Snake River Sugar Company bear interest at a weighted average fixed interest rate of 9.4%, are collateralized by our interest in The Amalgamated Sugar Company LLC and are due in January 2027. At December 31, 2008, \$37.5 million of such loans are recourse to us and the remaining \$212.5 million is nonrecourse to us. Under certain conditions, Snake River has the ability to accelerate the maturity of these loans.

We have an \$85 million revolving bank credit facility which matures in October 2009, generally bears interest at LIBOR plus 1.75% (for LIBOR-based borrowings) or prime (for prime-based borrowings), and is collateralized by 20 million shares of Kronos common stock we own. The agreement limits our ability to pay dividends and incur additional indebtedness and contains other provisions customary in lending transactions of this type. In the event of a change of control of us, as defined in the agreement, the lenders have the right to accelerate the maturity of the facility. The maximum amount we may borrow under the facility is limited to one-third of the aggregate market value of the shares of Kronos common stock we have pledged as collateral. Based on Kronos' December 31, 2008 quoted market price of \$11.65 a share, the Kronos common stock pledged under the facility provided the maximum borrowing availability of was \$76.8 million. At December 31, 2008, there was \$7.3 million in borrowings outstanding under the facility and \$1.4 million of letters of credit outstanding under the facility. At December 31, 2008 \$68.2 million was available for future borrowings under the facility.

Note 6 - Income taxes:

The Amalgamated Sugar Company LLC is treated as a partnership for federal income tax purposes. Valhi Parent Company's provision for income taxes (benefit) includes a tax provision (benefit) attributable to Valhi's equity in earnings (losses) of Waste Control Specialists, as recognition of such income tax (benefit) is not appropriate at the Waste Control Specialist level.

	<u>Years ended December 31,</u>		
	<u>2006</u>	<u>2007</u>	<u>2008</u>
	(In millions)		
Components of provision for income taxes (benefit):			
Currently payable (refundable)	\$(2.9)	\$.2	\$ (4.8)
Deferred income taxes (benefit)	<u>20.7</u>	<u>(16.2)</u>	<u>6.1</u>
Total	<u>\$17.8</u>	<u>\$ (16.0)</u>	<u>\$ 1.3</u>
Cash paid (received) for income taxes, net:			
Received from subsidiaries	\$ -	\$ (16.8)	\$ (11.0)
Paid to Contran	1.2	5.8	4.6
Paid to tax authorities	<u>.1</u>	<u>.1</u>	<u>.2</u>
Total	<u>\$ 1.3</u>	<u>\$ (10.9)</u>	<u>\$ (6.2)</u>

	<u>December 31,</u>	
	<u>2007</u>	<u>2008</u>
	(In millions)	
Components of the net deferred tax asset (liability) - tax effect of temporary differences related to:		
Investment in:		
The Amalgamated Sugar Company LLC	\$ (114.6)	\$ (106.3)
Kronos Worldwide	(204.7)	(194.2)
Federal and state loss carryforwards and other income tax attributes	5.2	3.9
Accrued liabilities and other deductible differences	6.2	7.1
Other taxable differences	<u>(11.9)</u>	<u>(10.9)</u>
Total	<u>\$ (319.8)</u>	<u>\$ (300.4)</u>
Current deferred tax asset	\$ 1.6	\$ 1.7
Noncurrent deferred tax liability	<u>(321.4)</u>	<u>(302.1)</u>
Total	<u>\$ (319.8)</u>	<u>\$ (300.4)</u>

Valhi, Inc.

Three Lincoln Centre
5430 LBJ Freeway, Suite 1700
Dallas, TX 75240-2697
(972) 233-1700
(972) 448-1445 (Fax)