



TSX: PD.UN | NYSE: PDS

PRECISION DRILLING TRUST

365

Down to Earth | ANNUAL REPORT 2006

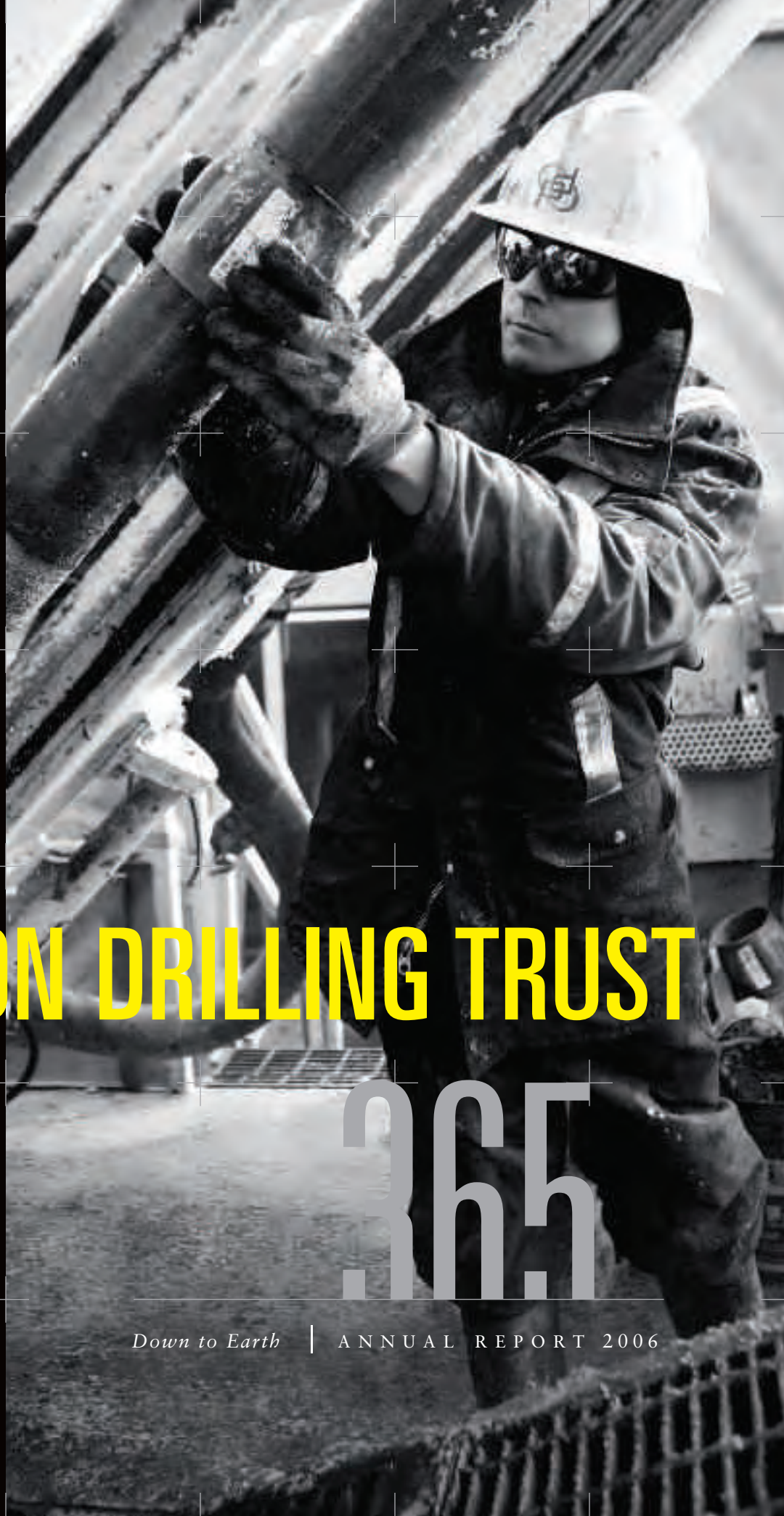

FINANCIAL HIGHLIGHTS

(Stated in thousands of Canadian dollars, except per diluted unit/share amounts)

Years ended December 31,	2006	2005	% change
Revenue	\$ 1,437,584	\$ 1,269,179	13
Operating earnings ⁽¹⁾	595,279	465,378	28
Interest, net	8,029	29,270	(73)
Premium on redemption of bonds	–	71,885	n/m
Loss on disposal of short-term investments	–	70,992	n/m
Other	(408)	–	n/m
Earnings from continuing operations before income taxes	587,658	293,231	100
Income taxes	15,146	72,383	(79)
Earnings from continuing operations	572,512	220,848	159
Discontinued operations, net of tax ⁽²⁾	7,077	1,409,715	n/m
Net earnings	579,589	1,630,563	(64)
Distributions to unitholders – declared	471,524	70,510	n/m
Net capital expenditures ⁽³⁾	233,693	140,077	67
Long-term debt	140,880	96,838	45
Total assets	1,761,186	1,718,882	2
Per diluted unit/share information:			
Earnings from continuing operations	4.56	1.76	159
Net earnings	4.62	13.00	(64)
Distributions to unitholders – declared	3.76	0.56	n/m
Number of units/shares outstanding, end of year (000s)	125,758	125,461	–

(1) Non-GAAP measure. See page 66.

(2) Includes gain on disposition of discontinued operations.

(3) Excludes acquisitions and discontinued operations.

n/m – calculation not meaningful.

ANNUAL GENERAL MEETING

The Annual and Special Meeting of the unitholders of Precision Drilling Trust will be held in the Enmax Ballroom at the Calgary Chamber of Commerce, 100 - 6th Avenue SW, Calgary, Alberta at 3:00 p.m. (Calgary time) on Wednesday, May 9, 2007.

Unitholders are encouraged to attend and those unable to do so are requested to complete and return the Form of Proxy.

Cover Photograph:

Super Single™ drilling rig in slant position – placing a centralizer on a joint of well casing.

Table of Contents

PRECISION

- 1 Cautionary Statement Regarding Forward-Looking Information and Statements
- 2 Executive Chairman's Message
- 4 President's Message
- 6 Down to Earth Values
- 8 Positioned for Growth
- 10 Operations at a Glance

PRECISION 24/7

- 12 Precision Drilling
- 14 Precision Well Servicing
- 16 Live Well Service
- 17 Precision Rentals
- 18 Rostel Industries
- 19 Columbia Oilfield Supply
- 20 LRG Catering
- 21 Terra Water Systems
- 22 Safety Management
- 24 Environment and Community
- 25 Corporate Governance
- 26 Trustees and Directors

FINANCIAL INFORMATION

- 30 Management's Discussion and Analysis
- 67 Financial Reporting
- 92 Supplementary Information
- 95 Unitholder Information
- 96 Corporate Information

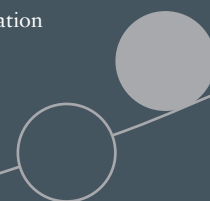

ANNUAL REPORT 2006

Precision Drilling Trust (the “Trust” or “Precision”) is Canada’s largest oilfield services company, providing contract drilling, well servicing and strategic support services to customers.

Precision returned to its Canadian drilling roots in 2005 after the sale of its energy services, international contract drilling and industrial maintenance operations and today is a company focused on what it does best.

Precision drills the wells that start the complex process of converting oil and natural gas into the fuels, electricity and other products that provide a better life for people. Precision supplies on-the-ground expertise – people, equipment and knowledge – to enable about one-third of western Canada’s conventional oil and gas production. Precision and its people are in the field 24 hours a day, 365 days a year, playing a vital role in the North American economy.

Down to Earth is a theme that captures the nature of oilfield work as well as the straightforward approach that has described Precision for decades.

Down to Earth also signifies the global responsibility to manage non-renewable resources and control the environmental impacts of resource development. It’s down to earth. It’s where we live.

After record financial results in recent years, North America’s oilfield services sector faces a more challenging environment in 2007. It’s Precision’s *Down to Earth* strategy that sets it apart from other companies and positions it for opportunities regardless of the operating cycle.

CAUTIONARY STATEMENT REGARDING FORWARD-LOOKING INFORMATION AND STATEMENTS

This Annual Report contains certain forward-looking information and statements, including statements relating to matters that are not historical facts and statements of our beliefs, intentions and expectations about developments, results and events which will or may occur in the future, which constitute “forward-looking information” within the meaning of applicable Canadian securities legislation and “forward-looking statements” within the meaning of the “safe harbor” provisions of the *United States Private Securities Litigation Reform Act of 1995*. Forward-looking information and statements are typically identified by words such as “anticipate,” “could,” “should,” “expect,” “seek,” “may,” “intend,” “likely,” “will,” “plan,” “estimate,” “believe” and similar expressions suggesting future outcomes or statements regarding an outlook.

Forward-looking information and statements in this Annual Report include, but are not limited to statements with respect to: 2007 capital expenditures, including the amount and nature thereof; 2007 distributions; performance of the oil and natural gas industry, including prices and supply and demand; expansion, consolidation and other development trends of the oil and natural gas industry; demand for and status of drilling rigs and other equipment in the oil and natural gas industry; costs and financial trends for companies operating in the oil and natural gas industry; world population and energy consumption trends; our business strategy, including the 2007 strategy and outlook for our business segments; expansion and growth of our business and operations, including diversification of our earnings base, the size and capabilities of our drilling and service rig fleet, our market share and our position in the markets in which we operate; demand for our products and services; our management strategy, including transitions in executive roles; labour shortages; the maintenance of existing customer, supplier and partner relationships; supply channels; accounting policies and tax liability; expected payments pursuant to contractual obligations; the prospective impact of recent or anticipated regulatory changes; financing strategy and compliance with debt covenants; credit risks; and other such matters.

All such forward-looking information and statements are based on certain assumptions and analyses made by us in light of our experience and perception of historical trends, current conditions and expected future developments, as well as other factors we believe are appropriate in the circumstances. These statements are, however, subject to known and unknown risks and uncertainties and other factors. As a result, actual results, performance or achievements could differ materially from those expressed in, or implied by, these forward-looking information and statements and, accordingly, no assurance can be given that any of the events anticipated by the forward-looking information and statements will transpire or occur, or if any of them do so, what benefits will be derived therefrom. These risks, uncertainties and other factors include, among others: the impact of general economic conditions in Canada and the United States; world energy prices and government policies; industry conditions, including the adoption of new environmental, taxation and other laws and regulations and changes in how they are interpreted and enforced; the impact of initiatives by the Organization of Petroleum Exporting Countries; the ability of oil and natural gas companies to access external sources of debt and equity capital; the effect of weather conditions on operations and facilities; the existence of operating risks inherent in well servicing, contract drilling and ancillary oilfield services; volatility of oil and natural gas prices; oil and natural gas product supply and demand; risks inherent in the ability to generate sufficient cash flow from operations to meet current and future obligations; increased competition; consolidation among our customers; risks associated with technology; political uncertainty, including risks of war, hostilities, civil insurrection, instability or acts of terrorism; the lack of availability of qualified personnel or management; credit risks; increased costs of operations, including costs of equipment; fluctuations in interest rates; stock market volatility; opportunities available to or pursued by us and other factors, many of which are beyond our control.

These risk factors are discussed in our Annual Information Form and Form 40-F on file with Canadian securities commissions and the United States Securities and Exchange Commission and are available on SEDAR at www.sedar.com and the website of the United States Securities and Exchange Commission at www.sec.gov, respectively. Except as required by law, Precision Drilling Trust, Precision Drilling Limited Partnership and Precision Drilling Corporation disclaim any intention or obligation to update or revise any forward-looking information or statements, whether as a result of new information, future events or otherwise.

The forward-looking information and statements contained herein are expressly qualified by this cautionary statement.

DOWN TO EARTH

365

Performance | 365 DAYS

Executive Chairman
March 9, 2007

HANK B. SWARTOUT



TIMES CHANGE

If there is one thing I've learned in my 20 years as Chairman of Precision it's the simple principle that times will change but values endure. Whether we had four rigs or 475 rigs the belief in that *Down to Earth* vision has driven this company forward. During 2006, Precision distributed \$445 million cash, or \$3.54 per unit, directly to unitholders. Quite an accomplishment considering we only had four rigs 20 years ago.

BUT VALUES ENDURE

Oil and gas prices rise and fall, governments will rewrite policies and the economy will grow at unpredictable rates. The environment we operate in constantly challenges us but Precision has prospered in good times and bad because of the commitment to value our people, invest in quality equipment and always stay financially prudent.

It is remarkable how closely our values today mirror the principles we stated in the first annual report to shareholders in 1985 when we were Cypress Drilling Ltd.

“Stringent cost control, well-maintained equipment ... one of the best safety programs in the drilling industry, minimal debt and reward for performance to employees will allow us to forge ahead carefully in the years to come.”

These principles have stood the test of time. Today, Precision is Canada's largest oilfield services company and an

industry leader in profitability, safety, technology and operating efficiency.

We have branded our core values *Down to Earth*. It is a sentiment that reflects Precision. With all our growth, we remained a company that kept its feet on the ground and focused on serving customers and building relationships.

As we have seen before, this is a time of transition. We face a more traditional operating environment after years of record activity but Precision has always been a company that created its own opportunities. Volatility is the norm in this industry but with experience and discipline we can manage it.

The succession of Precision's management continues as I assume the role of Executive Chairman in 2007. My day-to-day responsibilities have diminished as I relinquished the role of Chief Executive Officer. I will continue to provide vision and guidance to the Board of Directors and a management team

that has grown up with this company and has the ability to build on Precision's legacy of realizing value for unitholders.

I would like to acknowledge that Garth Wiggins will not stand for re-election as a trustee or director in 2007. Mr. Wiggins is a long-standing board member whose financial expertise and steady guidance has contributed greatly to Precision's success over the years.

I also want to welcome two new members to the Board of Directors – Stephen Letwin, Executive Vice President, Enbridge Inc., of Houston, and Allen Hagerman, Chief Financial Officer, Canadian Oil Sands Limited, of Calgary – who will provide objective industry insight and guidance for Precision.

The cyclical nature of the oilfield services business creates both challenges and opportunities. In the future, Precision's down to earth values and strategy puts us in a position to maximize unitholder value, just as in the past.

FOCUS AND FLEXIBILITY TO

As we evaluate our performance in 2006 and look to the opportunities in 2007 the phrase *Down to Earth* has come to stand for the attitude and business model that give Precision its competitive advantage. It explains who we are, captures what we do and points to how our flexible operating model is critical to Precision's ability to consistently create value for investors.

Precision delivered a third straight year of record operating earnings in 2006 and we kept our feet firmly on the ground. The operating environment in western Canada has shifted from overheated to uncertain during the second half of the year and we will rely upon our decades of experience at every level of the company as we adjust to the conditions and challenges for 2007.

That is the essence of *Down to Earth*. Take a long-term approach that is flexible enough to adjust to the day-to-day realities of the business while maintaining a focus on our core values. Commodity prices and rig activity levels retreated from historic highs in 2006 but we did what we set out to do in our 2005 annual report. We stayed focused on the fundamentals – doing the job safely, on time and on budget.

President and Chief Operating Officer
March 9, 2007

GENE C. STAHL

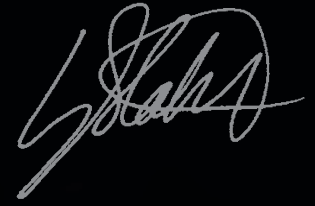

DELIVER RESULTS

In 2006, we initiated our expansion into the U.S. market, continued with equipment upgrade initiatives and launched an organic growth strategy that will increase our drilling rig fleet by 13% over the 2005 rig count of 230.

Rather than acquire assets in a high-price market, we focused on investing “in-house” to improve our rig technology. Rigs are 30-year-plus assets and reinvesting profits into assets that perform better has always been Precision’s approach.

All our success comes from our people in the field. From Alberta to Texas, Precision’s people are on the job in all conditions 24/7 creating value for our customers.

We are in a more challenging period for the oilfield services sector and it goes beyond the swings in oil and natural gas prices we saw last year. Surging energy demand in recent years triggered a large

increase in the supply of drilling rigs and other oilfield service equipment.

Rig capacity will exceed moderating demand in 2007. This could be the start of an industry rationalization that effectively retires unproductive land drilling equipment in North America. With this shift, we believe operating efficiency is paramount. Precision expects this trend will be more prevalent in the United States land drilling market and presents opportunities to redeploy excess supply from Canada.

The industry also faces technical challenges. As conventional oil and gas basins in North America mature, it is increasingly difficult for our customers to maintain production. Energy demand, however, is not declining and new supplies are increasingly focused on unconventional oil and gas plays such as oil sands, coal bed methane, tight gas and natural gas in shale.



Down to Earth | PRESIDENT'S MESSAGE

Unconventional resources are complicated and expensive to develop. Customers require better equipment and more innovative technology to deliver lower costs to make projects viable. Our investments in people, equipment and relationships with customers make us a company that will prosper at a time when the best performers are those who can do something better for the customer.

From our Super Single™ and AC electric triple drilling rigs to proven delivery service systems, Precision's investment in innovative technology gives us the ability to do a better job for customers and positions us for long-term sustained growth. Our organizational structure is designed to support our field operations and we create value by improving efficiency.

As customers demand more from suppliers, Precision's advantages come more sharply into focus. Precision is already Canada's largest oilfield services company and among the industry's most profitable enterprises. Our services include drilling and service rigs augmented by divisions that provide camp and catering services, snubbing, wastewater treatment,

procurement and distribution of oilfield supplies, specialty equipment rentals and the manufacture and repair of rigs.

Delivering earnings growth will be a challenge in 2007, but as Precision has shown throughout its history there are opportunities in any market.

The Canadian Association of Oilwell Drilling Contractors (CAODC) forecasts 19,023 wells will be drilled in Canada in 2007 after 22,575 wells in 2006. The CAODC originally forecast 26,070 wells would be drilled in 2006 but by summer it was clear commodity prices would not foster that level of activity. By the fourth quarter, the landscape looked similar to 2001, when record activity and earnings gave way to weakness in the final three months. Late in 2006, there were year-over-year declines in key metrics such as rig activity and trends in spot market day rates.

The critical revenue generating winter drilling season in 2006/2007 saw more uncertainty over commodity prices, producer budgets, government policies and the state of the economy than at any time in the last five years.

However, with approximately 70% of drilling in Canada targeting natural gas and steep productivity declines from North American gas wells, any near-term slowdown in drilling sets the stage for a turnaround in prices and drilling. There are also opportunities from the close to 190,000 producing wells in Canada that require workovers to offset production declines. Precision's expansion into the United States gives us the ability to put rigs in locations with opportunities for significantly higher annual utilization rates than are typical in Canada.

PRECISION IN 2006

In our last annual report, we said "2006 will be another year of significant demand for services and strong performance" for Precision. This proved to be accurate. Precision's revenues rose by 13% to \$1.44 billion while operating earnings rose 28% over 2005 to \$595 million in 2006 on strong activity levels in the first half of 2006 and pricing that was sustained throughout the year.

DOWN TO EARTH VALUES

The goal of no workplace injuries was the origin for Precision's Target Zero vision. From the top down, a commitment to that vision reinforces and improves upon the policies and practices that make Precision a safety leader in the industry.

It is much the same with *Down to Earth*. The phrase is rooted in the company culture and brings together a number of core values that have endured throughout Precision's history.

These *Down to Earth* values help assure that Precision is moving in the right direction with a common sense of purpose.

Down to Earth Safety

TARGET ZERO

Precision's vision is zero injuries. Injuries are not acceptable so Precision's focus is on continuous safety improvement through awareness and risk reduction. In 2006, 281 rigs, 20 snubbing units, 86 camps and 12 shops achieved Target Zero!

Down to Earth Support

THE FIELD COMES FIRST

It all starts in the field. Precision succeeds because, even under some pretty tough conditions, employees in the field get the job done. Precision's people know that, from continuous training to the vast support services provided by Canada's largest drilling contractor, a world-class company is behind them.

Down to Earth Technology

THE BEST EQUIPMENT

Precision believes in investing in and maintaining top quality equipment. Precision takes advantage of the latest innovations and technology to provide customers the right equipment to increase productivity and deliver lower total well costs. With its in-house engineering, manufacturing and repair facilities Precision is able to improve its fleet with on-going rig maintenance and upgrades.

DOWN TO EARTH VALUES

Down to Earth Communication

FACE TO FACE

Precision believes that candid face-to-face conversation among people from across the company produces common sense solutions. Management has continual presence in the field to promote and encourage open dialogue.

Down to Earth Family

THE PRECISION FAMILY

Like a family, Precision has deep roots which promote a sense of loyalty and long-term thinking. People come first at Precision. With teamwork and safety so critical on the job, people look out for each other every day.

Down to Earth Solutions

EMPOWERED TO AFFECT CHANGE

Precision expects its employees to take the initiative and contribute ideas to move the company forward. This attitude fosters the appropriate balance between people and processes in the workplace and makes even better use of Precision's key asset, its people.

Down to Earth Performance

DESIRE TO BE THE BEST

Precision strives to be a top performer in all its operations and wants its employees to share that goal. Precision's commitment to its core values tells employees the company means what it says and gives them the opportunity to make the company better.

Down to Earth Relationships

EMPLOYEE+CUSTOMER+ SUPPLIER+UNITHOLDER

Precision is in the relationship business and seeks to develop mutually beneficial partnerships with suppliers and customers with the goal of delivering superior returns to investors.

After reaching US\$15.39 per million British Thermal Units in December 2005, natural gas prices slid to US\$3.62 by September and stayed depressed into the relatively warm start to the winter in North America. Oil fell to nearly US\$50 a barrel early this year from an all-time high of US\$78.40 last July and 2007 promises even more price volatility.

During 2006, we began to establish a track record of distributions. However, the announcement from the Government of Canada on October 31, of its plan to tax distributions to investors in income trusts, created confusion in the sector. We will continue to monitor these developments and will adjust as required to provide the best value for Precision's unitholders. As when we converted to a trust, our legal structure will have no impact on operations.

Precision achieved solid fleet utilization in 2006. Our 241 drilling rigs posted 44,938 operating days, or 53% utilization. Our 237 service rigs logged 480,137 operating hours, or 56% utilization. With a slowdown in activity

toward the end of the year and a 9% increase in the industry rig fleet, Canadian drilling utilization rates decreased four percent from 2005. Service rig utilization rose one percent year over year.

Contract drilling and its support business accounted for approximately 70% of Precision's revenues in 2006. Well servicing and its supporting business divisions made up 30%.

2007 OUTLOOK

The industry in western Canada is clearly in transition from an overheated demand environment that led to record financial results and put tremendous strains on infrastructure and personnel. There appears to be a shift to a more normal operating environment.

For the first quarter of 2007, industry well licensing for natural gas in Canada is approximately 30% lower year over year and drilling rig utilization is 19% lower. The downward momentum will compound the effects of the seasonally soft "spring break-up" in the second quarter and there will be considerable

pressure on customer pricing and Precision's profit margins.

Despite near-term weakness due to volatile natural gas pricing for customers, we remain confident in the North American gas drilling market. Precision's growth outlook is focused on initiatives that involve better technology and value to customers. Entry into the U.S. market is a key growth factor. Weakness in the oilfield services sector also provides a greater opportunity to consider acquisitions. We will evaluate acquisitions to consolidate current markets or provide growth in new markets.

To solidify customer relations, we will focus on offering total well cost savings for the premium day rates Precision traditionally commands. We will provide customers money-saving services, cost-control systems, versatile equipment, proximity to locations and industry leading support services.

Ultimately, we believe Precision's focus on our *Down to Earth* values and the service proposition for customers creates wealth for our unitholders.

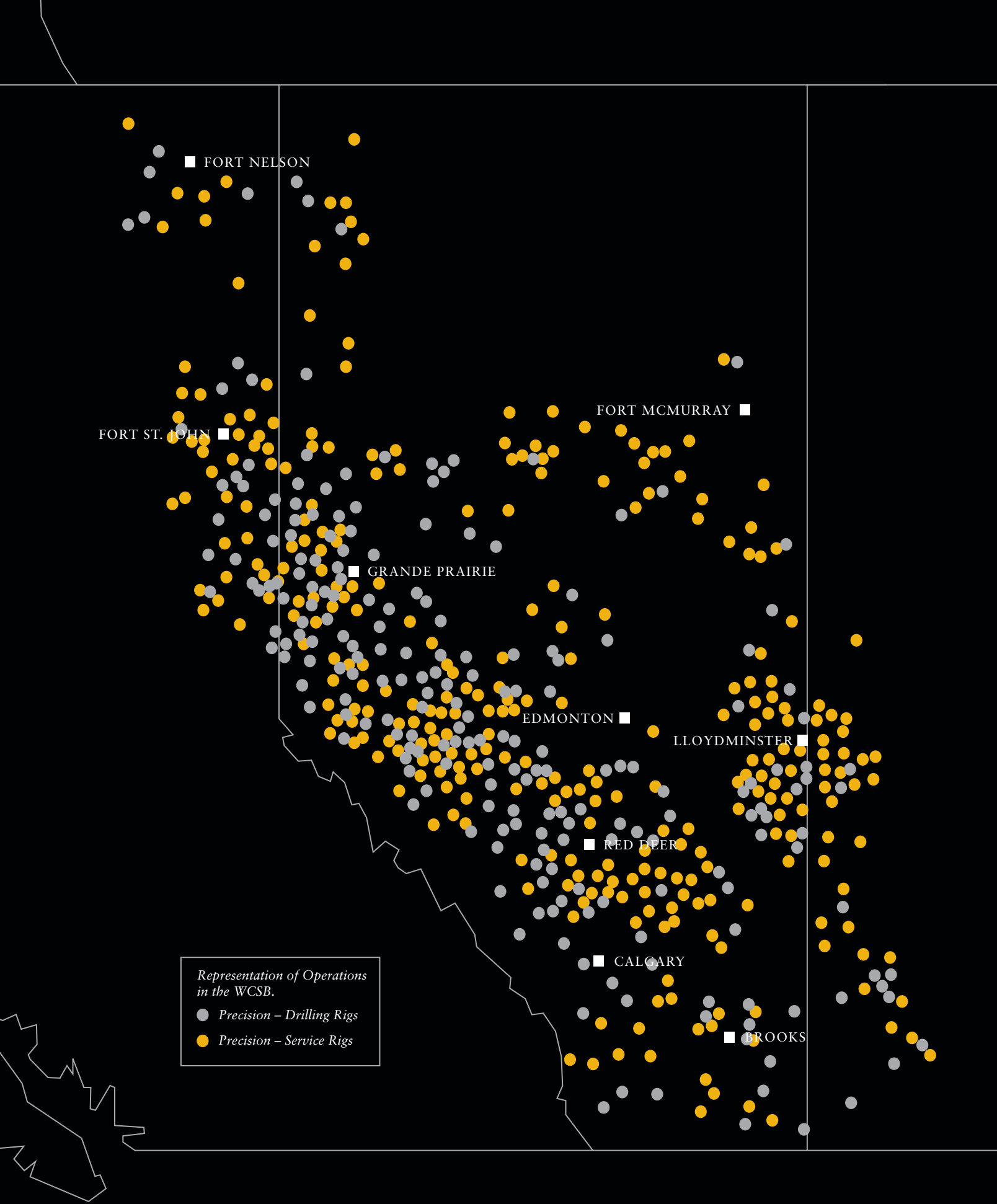

NORTH AMERICAN OIL AND GAS BASINS

□ Precision Operating Areas



Source: Canadian Association of Petroleum Producers, Precision

Down to Earth | POSITIONING

POSITIONED FOR GROWTH

Precision is Canada's largest oilfield service provider with a fleet of 240 drilling rigs and 237 service rigs geographically dispersed throughout the Western Canada Sedimentary Basin ("WCSB").

The vast and varied oil and natural gas resources in the WCSB have provided Precision the opportunity to acquire unparalleled experience in meeting customer needs over a 55 year operating

history. Precision provides services which enable its customers to drill, complete and workover wells for conventional oil and natural gas reservoirs as well as growing unconventional energy sources such as heavy oil, oil sands, coal bed methane and tight natural gas.

Growing demand for natural gas and the steep production decline rates from maturing gas reservoirs has led to sustained higher levels of drilling activity in Canada and the United States. In 2006, approximately 75% of land drilling rig activity in North America targeted natural gas exploration and development.

Precision's employees and equipment are products of a highly competitive environment for oilfield services. Equipment, such as the successful Super Single™ drilling rig, is highly versatile and able to meet varied fit-for-purpose customer drilling requirements.

From its highly efficient operating platform in western Canada, Precision is working with core customers in Canada to secure market expansion in areas of the United States that have growing unconventional natural gas production and the supporting infrastructure to get the gas to consumers. As part of its staged entry into the United States, Precision currently has operations in Texas and Colorado.

■ REGINA



DOWN TO EARTH OPERATIONS

Equipment (December 31, 2006)

PRECISION DRILLING (241 DRILLING RIGS)

- Singles: 14
- Super Singles™: 29
- Coiled tubing: 11
- Doubles: 94
- Light triples: 44
- Heavy triples: 49

PRECISION WELL SERVICING (237 SERVICE RIGS)

- Freestanding mobile singles: 92
- Mobile singles: 12
- Skid doubles: 65
- Freestanding mobile doubles: 9
- Mobile doubles: 44
- Freestanding slants: 15

LIVE WELL SERVICE

- Rig assist snubbing units: 25
- Stand alone snubbing units: 1

LRG CATERING

- Camps: 101
- Dormitories: 3

PRECISION RENTALS

- Specialty drill pipe joints: 10,000
- Surface equipment: 3,700
- Well control equipment: 1,100
- Accommodation units: 315

TERRA WATER SYSTEMS

- Extended aeration units: 50
- Rotating biological contact units: 1

WORKFORCE: 6,500

Manhours (2006): 13.7 million

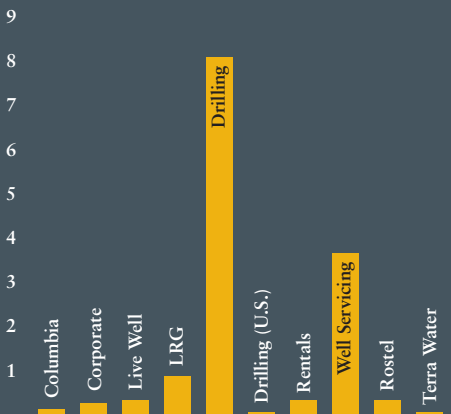

CONTRACT DRILLING SERVICES SEGMENT

The Contract Drilling Services segment includes Precision Drilling, LRG Catering, Columbia Oilfield Supply and Rostel Industries and generates approximately 70% of Precision's annual revenue.

ROSTEL INDUSTRIES

LRG CATERING



Down to Earth | PERFORMANCE

OPERATIONS

TERRA WATER SYSTEMS



COMPLETION AND PRODUCTION SERVICES SEGMENT

The Completion and Production Services segment includes Precision Well Servicing, Live Well Service, Precision Rentals and Terra Water Systems and generates approximately 30% of Precision's annual revenue.

PRECISION DRILLING

Precision operates the largest fleet of drilling rigs in Canada and one rig in the United States. The 240 rigs represent about 29% of the Canadian contract drilling industry.

LRG CATERING

LRG provides food and lodging for crews working in remote locations to improve operational efficiency for customers and provides a home away from home for workers.

COLUMBIA OILFIELD SUPPLY

Columbia is an essential extension of the company-wide procurement process. It provides purchasing power, standardized product selection and coordinated distribution of goods for all Precision operations.

ROSTEL INDUSTRIES

Rostel enables Precision to design, build, refurbish and certify drilling and service rig components. It also helps ensure better control of equipment specifications and delivery schedules.

COLUMBIA OILFIELD SUPPLY

PRECISION DRILLING

AT A GLANCE

TSX

NYSE

PD.UN

PDS

PRECISION WELL SERVICING

LIVE WELL SERVICE

PRECISION RENTALS

PRECISION WELL SERVICING

Precision Well Servicing is Canada's largest service rig contractor with 237 rigs. The rigs conduct completions and workovers and represent about 23% of the industry.

LIVE WELL SERVICE

Live Well operates 26 snubbing units that conduct completion and workover operations on producing wells. It represents about 30% of the snubbing industry.

PRECISION RENTALS

Precision Rentals supplies specialty drill pipe, surface equipment and wellsite accommodations to operators from stock points across western Canada. It represents about 10% of the oilfield rentals industry.

TERRA WATER SYSTEMS

Terra Water provides portable wastewater treatment to reduce the environmental impact at remote worksites. It represents about 10% of the industry.



Business

Super Single™ Rig 255 |

Location

East of Calgary

OPERATIONAL EFFICIENCY

12.44

Down to Earth | PERFORMANCE

PRECISION DRILLING

Oil and natural gas drilling in Canada and the United States requires specialized equipment and knowledge to deal with the complex geology, often-harsh weather, a competitive marketplace and stringent environmental and safety standards.

Most oil and gas producers do not own the equipment required to drill their wells. They find it more efficient to utilize the workers, equipment, and technical skills of a service company like Precision.

For more than five decades, Precision Drilling's roots have been in the Western Canada Sedimentary Basin; an area that spans from Virden, Manitoba, to Fort Nelson, British Columbia. Servicing such a vast area can be a challenge but Precision has a fleet of 240 drilling rigs that are adaptable for a variety of natural gas, crude oil and oil sands drilling prospects ranging in depths from 600 to 6,000 metres. The ability to get a rig to a job site quickly and efficiently is one of Precision's key competitive advantages in delivering lower total well costs.

Operational efficiency and safety are critical for drilling contractors in North America and Precision works closely with customers to ensure both. Once drilling starts, it typically continues 24/7 until the job is done. In 2006, the average well in western Canada took just over seven days to drill but drilling time per well can range from less than a day to more than a year.

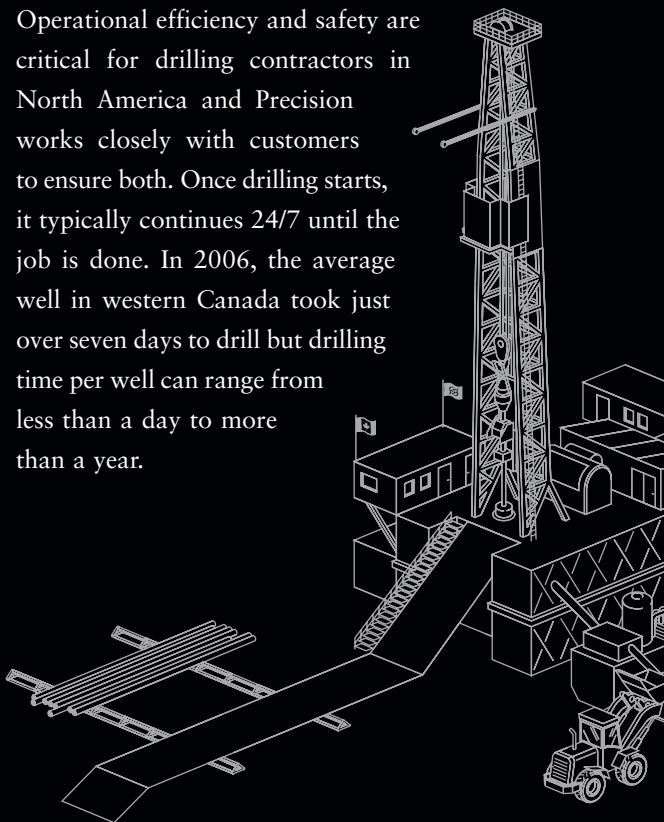

PRECISION DRILLING

Precision's drilling rigs generally operate with three crews of five – driller, derrickman, motor-man, floor hand and lease hand – working two weeks on and one week off. Each rig essentially operates as a self-contained business unit and while a well is being drilled the rig manager will oversee operations onsite the entire time. The crew works with a representative from the operating company to drill to a pre-determined target that can be the size of a single-car garage. The target will vary in depth and direction depending on the well type – vertical, directional or horizontal.

Relationships with customers have always been vital to Precision's success. In 2006 Precision initiated U.S. operations in Texas and Colorado through some of its long-standing customer relationships in Canada.

Precision's fleet can drill virtually all types of on-shore conventional and unconventional oil and gas deposits in North America. It is particularly adept in developing unconventional resources such as oil sands, coal bed methane and tight gas. The increase in drilling-intensive unconventional resource plays is creating opportunities for technically innovative and operationally efficient drillers like Precision.

INNOVATION:

To improve on its highly successful Super Single™ drilling rig, Precision is applying state of the art AC-powered drives to the new generation of this versatile rig as well as its new fast-moving 4,000-metre AC drive triple rigs.



THAT LOWERS COSTS



Business

Location

Service Rig 51 | Near Rocky Mountain House, AB

SUSTAINING OR IMPROVING

PRECISION WELL SERVICING

After a well is initially drilled, the operator contracts a company such as Precision Well Servicing to supply the crew and equipment to complete the well. A service rig helps to initiate production, provide maintenance or re-completions to sustain or improve productivity during the life of a well and abandon the well.

Well servicing requires its own unique skill set and – in addition to the physical work, harsh weather and other factors – crews must deal with the potential dangers and safety concerns of working with pressurized well bores.

Precision Well Servicing has a fleet of 237 service rigs deployed throughout the vast Western Canada Sedimentary Basin. Precision deploys its fleet in the major producing centres in western Canada to improve efficiency and reduce travel. The operations have two distinct functions – completions and workovers. Completions accounted for about 40% of total activity for Precision Well Servicing in 2006 while workovers accounted for 60%.

Completions prepare a newly drilled well for production and can involve cleaning the well bore and installing production tubing as well as wellheads and downhole equipment such as pumps. Workovers take place over the producing life of the well and involve a variety of activities to restore or enhance production.

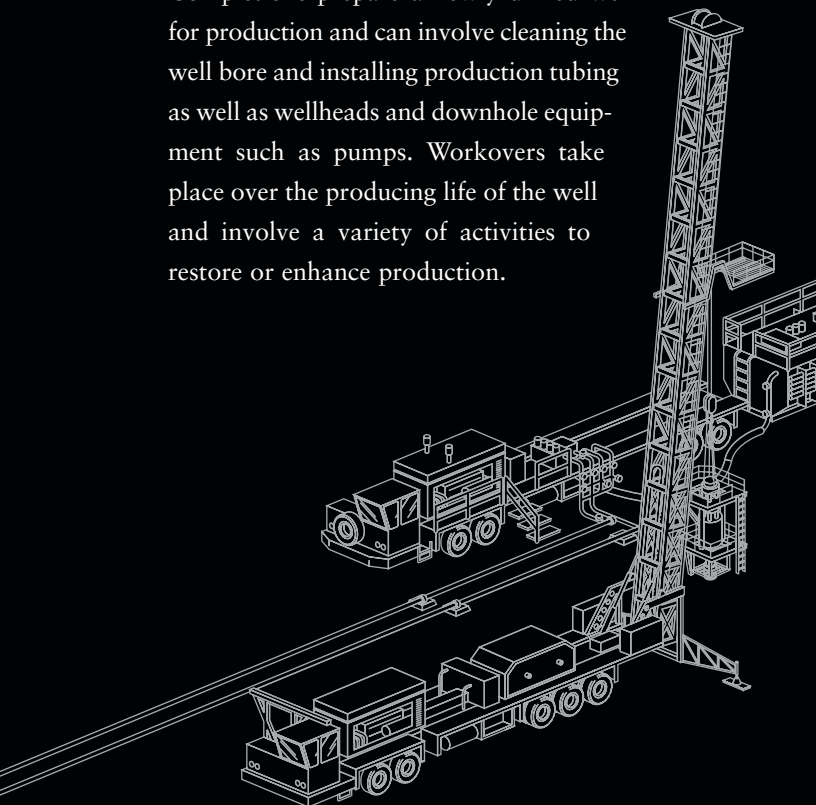

PRECISION WELL SERVICING

Servicing wells often means coordinating activities of several companies so work normally takes place in daylight hours. A typical service rig crew has four members (driller, derrickman and two floor hands) in addition to the rig manager. Jobs are typically shorter in well servicing than contract drilling so the ability of a service rig to move quickly from one site to another is critical.

A typical gas well in western Canada is likely to require one or two workovers during its operating life compared with four or five workovers for conventional oil wells. Wells for some heavy oil and bitumen production could require many workovers during their lifecycle.

The number of wells drilled in Canada each year has doubled in this decade compared with the 1990s with a particular increase in natural gas and heavy oil drilling. With close to 190,000 producing wells currently in western Canada as potential candidates for workovers and 20,000 new wells drilled each year that must be completed and maintained, well servicing has significant growth potential for Precision.

INNOVATION:

Development of a versatile service rig that is multi-functional and able to adapt to a variety of well designs in heavy oil applications. The rig will service wells from vertical or slant positions and have the ability to add or remove various components to match the job specifications of our customer.

WELL PRODUCTIVITY

17:45

Down to Earth | PERFORMANCE





Business Snubbing Unit SA-1 | *Location* East of Lacombe, AB

SPECIALTY CONTROL EQUIPMENT

09:17

Down to Earth | PERFORMANCE

LIVE WELL SERVICE

Precision's snubbing business, Live Well Service, complements traditional well servicing by providing customers the ability to work on the well bore, under pressure, while production is suspended. It eliminates the need for the use of fluids to stop production which can damage delicate producing formations and which are costly to dispose of.

Safety is absolutely critical when working with a producing well and snubbing crews use specialty pressure-control equipment to remove and replace downhole pipe. Since pressure is maintained, crews can push (snub) the pipe into the wellbore in steps similar to how a boat moves through a water lock system.

There are essentially two types of snubbing units – rig assist and stand alone. Rig assist units work with a rig to complete the snubbing activity for a well. Stand alone units do not require a service rig on site and are capable of snubbing and many other services traditionally completed by a service rig.

Snubbing is primarily used to enhance natural gas production and as more gas wells are drilled each year in western Canada, producers are increasingly aware of the advantages of snubbing.

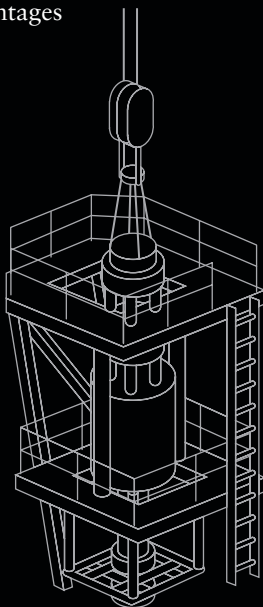

PRECISION RENTALS

Most operators do not own the specialty equipment used in oil and gas operations and rely on suppliers such as Precision Rentals for access to large inventories of drilling, completion and production equipment including specialty drill pipe, well control equipment and on site offices and accommodations.

Precision Rentals allows operators to focus on their core business and avoid the cost and infrastructure to buy, warehouse and maintain costly equipment for specific applications. Precision has the resources to ensure it keeps up with the latest advances in technology so it can provide customers with the right equipment at the right time to do the job.

Precision Rentals takes a one-stop-shopping approach to customer service with an inventory of 15,000 pieces of equipment from specialty drill pipe and blowout preventers to more than 300 on site offices and living quarters for supervisors and technical staff.

Precision Rentals has 5 operating centres and 14 stock points throughout western Canada as well as a central technical support centre in Nisku, Alberta. This logistical strength helps Precision Rentals reduce transportation costs and ensures equipment is available where and when it is needed.

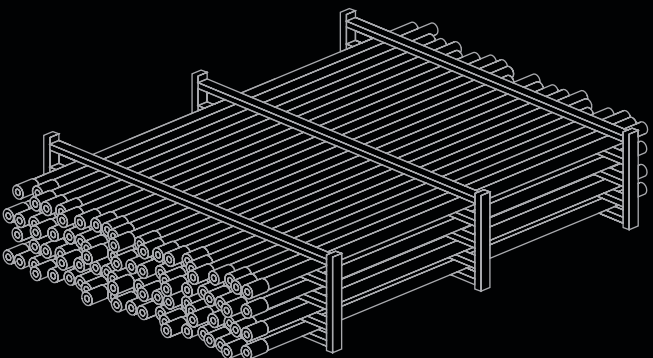



Business
Precision Rentals Yard |

Location
Nisku, AB

THE RIGHT EQUIPMENT, ON TIME

09:26

Down to Earth | PERFORMANCE

Business

Location

Rostel Manufacturing Facility | Calgary

RIG FABRICATION AND REPAIR

16:55

Down to Earth

PERFORMANCE - SUPPORT



ROSTEL INDUSTRIES

The oil and gas industry is an equipment dependent business and Rostel provides Precision with high quality in-house engineering, machining, fabrication, component manufacturing and repair services for its drilling and service rigs.

About 70% of Rostel's activities support Precision business units. Its ability to repair or provide new components for either drilling or service rigs ensures Precision's fleet has the highest levels of efficiency and reliability.

Rostel designs and builds more than 50% of the components for Precision's flagship Super Single™ drilling rigs and is currently developing a new AC-powered top drive that can be applied to both new rigs and retro-fitted to improve the versatility of many of Precision's existing rigs.

Rostel is a key aspect of the company's vertical integration and competitive advantage in delivering lower overall well costs for customers.

Operating around the clock, Rostel's Calgary shop gives Precision the ability to control cost, quality and production schedules. Rostel also provides important inspection and certification of rig components such as masts, substructures, overhead equipment, well control equipment and handling tools.

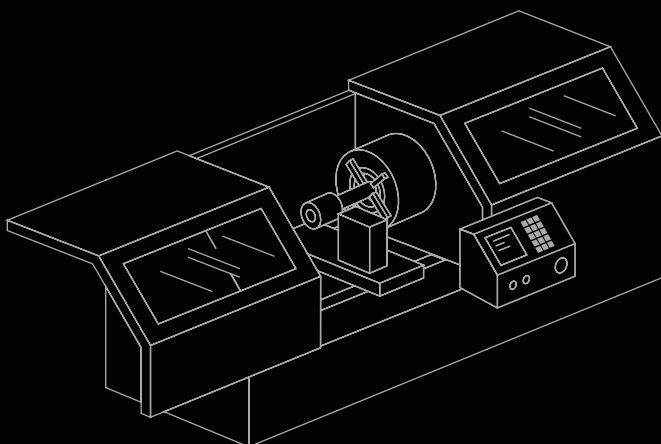

COLUMBIA OILFIELD SUPPLY

When Precision is running flat out during the winter drilling season, Columbia's value is most evident. Each day more than 50,000 pounds of consumables leave its warehouse on trucks for deliveries to Precision's 475 drilling and service rigs.

From purchasing power and standardized product selection to coordinated distribution, Columbia's inventory management and demand anticipation contribute to Precision's competitive advantage.

Columbia gives Precision the ability to ensure that its rigs are supplied with standardized products for all of its equipment. Precision has direct control over supply distribution to field destinations to ensure that crews in the field will have the right supplies and equipment when and where needed.

At the distribution hub in Edmonton, Columbia stocks more than 2,600 types of goods and materials for the rigs. The product lines include everything from valves and gaskets to steam heaters, sledgehammers and pipe lubricant.

About 90% of Columbia's activities support Precision operations and it plays a key role in supply chain management for the company.

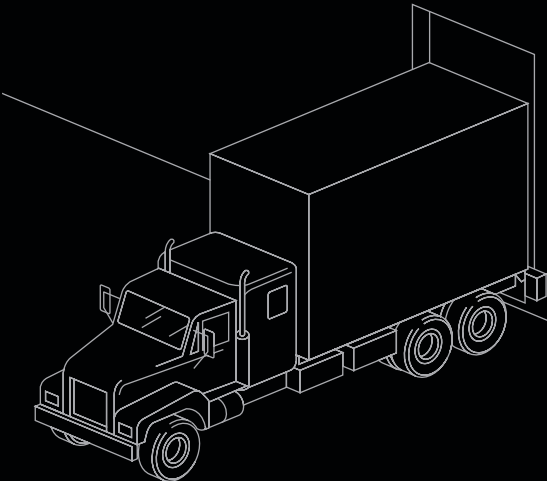



Business
Columbia Warehouse | *Location*
Edmonton

DELIVERING CONSUMABLE SUPPLIES

17:51

Down to Earth | PERFORMANCE - SUPPORT



Business
LRG Camp 168 | *Location*
West of Nanton, AB

PROVIDING HOME AWAY FROM HOME

11:28

Down to Earth | PERFORMANCE – SUPPORT

LRG CATERING

As the oil and gas industry in western Canada works in more remote locations in search of new reserves there is increasing demand for crews to stay near the wellsite throughout the drilling process.

The focus of LRG Catering is to provide workers a home away from home, with good food and comfortable accommodations so they are ready to work their next shift.

LRG, which recently opened a new operations centre in Edmonton, serves Precision and other companies in upstream oil and gas as well as other industries that operate in remote locations in western Canada.

LRG has approximately 100 camps that include five or six units and can accommodate 20 to 25 crew members. It can also provide food service for all field workers on a location. LRG also has the ability to configure several of its camps and dormitories on a single site to create a base camp for major projects, which can house as many as 200 workers and provide up to 1,000 meals a day.

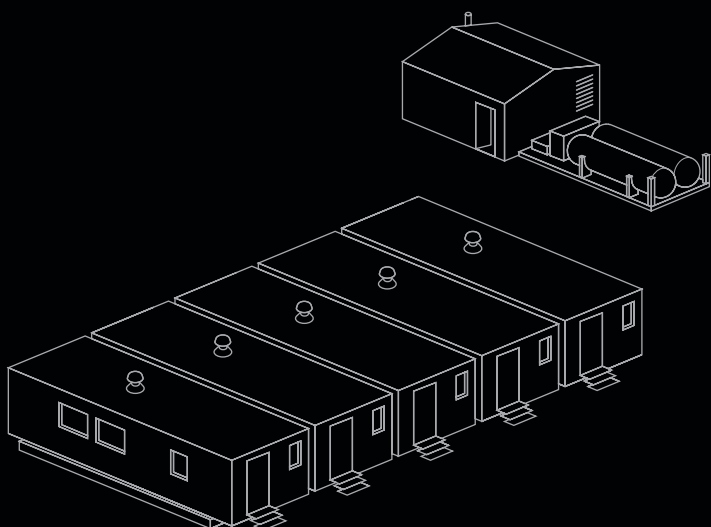

TERRA WATER SYSTEMS

Terra Water Systems designs and builds treatment units that minimize the environmental impact from camp generated wastewater. These treatment units are built for the rigors of remote work sites and Canada's environmental conditions.

Precision acquired Terra Water in August 2006 to complement its existing camp and catering services and augment its rental accommodation business. Terra Water's portable wastewater treatment units address the increased focus by operators to minimize the environmental effects related to their remote work activities.

The units are built to industry-leading standards. Terra Water provides regular servicing for all of its equipment and tests treated effluent samples to ensure the units are producing high quality treated effluent with no detectable odours.

Terra Water's large units can accommodate camp sites of up to 50 people and several units can be combined to serve large-scale base camp configurations. To meet specific requests from clients, Terra Water has developed a smaller model which is better suited to lower volume requirements of remote locations that accommodate less than 15 people.

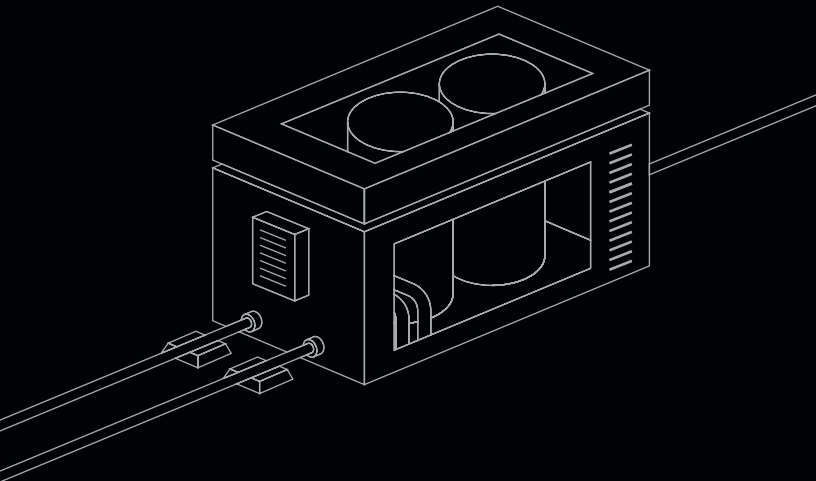

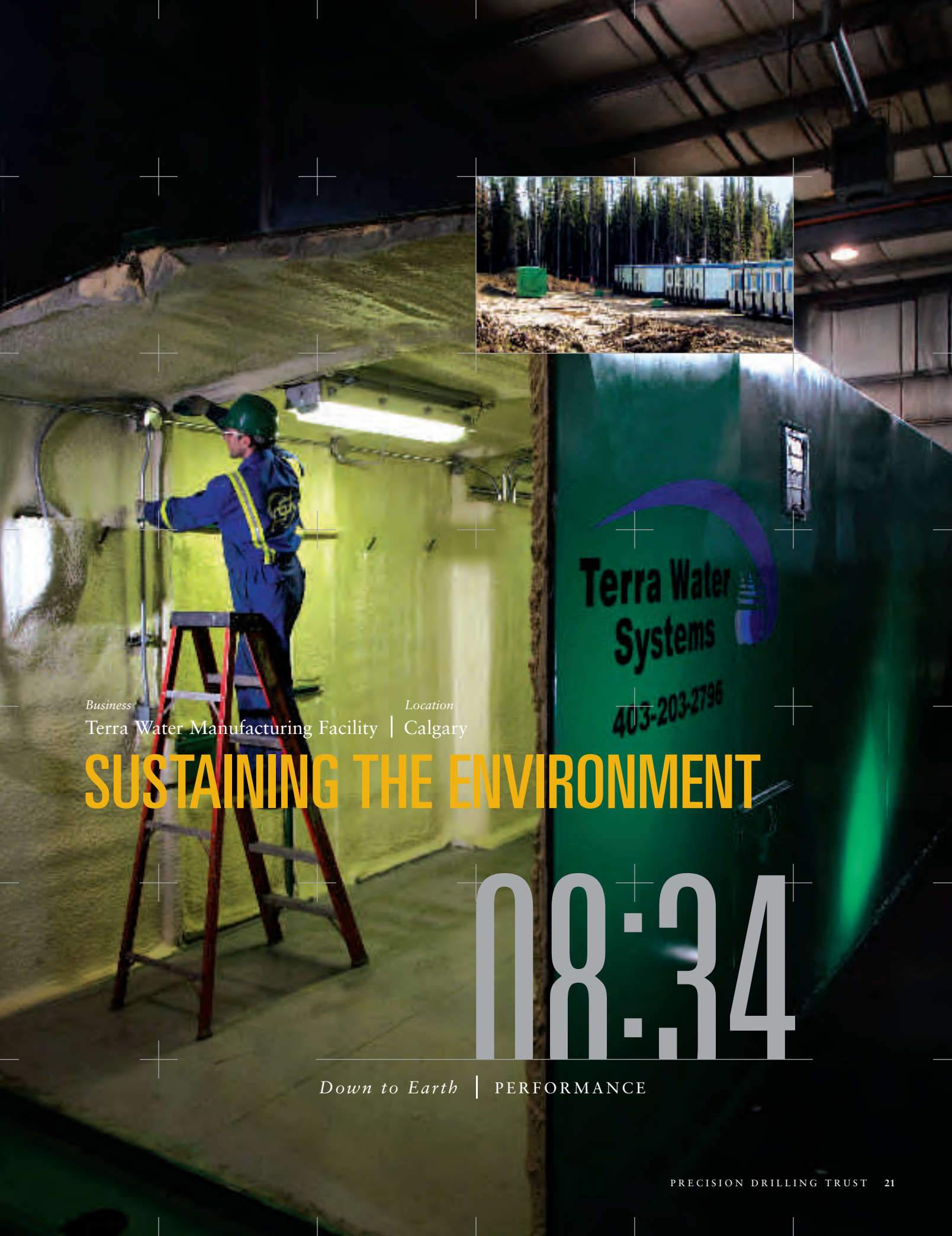

Business
Terra Water Manufacturing Facility | *Location*
Calgary

SUSTAINING THE ENVIRONMENT

08:34

Down to Earth | PERFORMANCE



Down to Earth | SAFETY MANAGEMENT

As we have stated in the past, when it comes to safety, Precision wants to “make it personal”. We want every employee to think about their personal safety on and off the job starting with driving to the job site safely, working safely through the day’s activities and returning home safely.

Equally, we want every employee to think about the safety of their co-workers, as well as the safety of our contractors and customers.

For Precision, safety is all about our people – our people taking ownership for their own safety, and making the safety of the people around them their primary concern. As a leader in the Canadian oilfield services industry, Precision believes that each of our employees can be a safety leader on the job. Safety is a core value that our employees strive to apply to every aspect of their job, every single day.

Building on the success of our people is a theme for Precision in 2007. The past year was the safest in Precision’s history and the success achieved by our employees resulted in fewer people injured. The acknowledgement of 2006 accomplishments and the reinforcement of these safe work successes is expected to move Precision closer to its Target Zero vision.

In a people-based industry like oilfield services, a company’s performance is tied directly to the health and safety of people in the field doing the job. Safety is a fundamental contributor to operating performance and the financial results the company generates for its unitholders.

Target Zero sets an ambitious but straightforward objective for Precision and its people: achieve zero incidents. That vision was laid out by Precision’s Executive Chairman, Hank Swartout, years ago with the message “we will not budget to hurt less people, we will work toward hurting no one.”

The focus on working safely is one of Precision’s most enduring values. Working in the oil and gas industry has always had inherent risks. It can be tough and physically demanding and often means working in harsh weather conditions. As a result, a constant focus on working safely is required by everyone on the job site.

Workplace safety accomplishments by Precision’s employees in 2006 resulted in:

- a 28% reduction in workplace injuries - 124 fewer employees were injured; and
- 5,637 employees achieved Target Zero in 2006 by working “recordable free” for the entire year.

Improving on these accomplishments is our motivation for 2007. To meet the task, it is imperative that all Precision employees, management and customers maintain the initiative to always make safety awareness their highest priority. That is a cornerstone of Target Zero “It’s People ... It’s Personal”.

Clearly, business units in 2006 remained vigilant and focused on Precision’s safety awareness principles. This led to numerous specific achievements in 2006:

- 90% of the Precision Drilling rigs and Precision Well Servicing rigs recorded no lost time incidents.

DOWN TO EARTH EXAMPLES OF PRECISION'S SAFETY CULTURE

- Senior management supports safety through field visibility
- Safety initiatives are an important element of the annual budget process
- Support employees through ongoing education
- Investment in new technology includes focus on safety
- Safety department carried out 2,000 field visits in 2006
- Rig crews conduct pre-tour meetings
- An employee's right to refuse unsafe work conditions is tracked and supported
- Workers review safety analysis and safe work procedures before critical tasks
- Safety observations are conducted at worksites
- Learnings are shared at the work site
- High standards of housekeeping are maintained
- *Drive to Survive* – safe driving is encouraged at all times
- Safety is motivated for the right reasons – It's People ... It's Personal

- 281 Precision Drilling rigs and Precision Well Servicing rigs achieved Target Zero.
- 86 of the LRG Catering camps achieved Target Zero.
- 20 of the Live Well Service snubbing units achieved Target Zero.
- Columbia Oilfield Supply achieved Target Zero.
- Terra Water Systems achieved Target Zero.
- Precision Drilling Oilfield Services, Inc. in the U.S. achieved Target Zero.
- Precision Rentals operated with zero lost time incidents.
- Rostel Industries was awarded the Best Safety Performer Award by Alberta Human Resources and Employment.

Precision's activities generated more than 13.7 million manhours in 2006, including 2.3 million in the second quarter with not a single lost-time incident in any business unit.

A key improvement area for 2007 will be driving safety, both on and off the job, which is the biggest threat to people working in the industry. Driving is the leading killer in the Canadian oil and gas service industry. Precision has launched a number of initiatives to reinforce basic principles associated with safe driving. For all of Precision's on-the-job success in 2006, there were members of the Precision family who died in automobiles off the job.

Precision has worked to promote its safety ideals and practices throughout the oil and gas industry through peer-to-peer learning. As a member of the Canadian Association of Oilwell Drilling Contractors, Petroleum Services Association of Canada and Canadian Petroleum Safety Council, Precision shares its experiences and best practices with industry members while learning from their experiences to improve workplace safety.

The Target Zero safety vision is the focal point for all of Precision's health and safety activities.

Precision begins reinforcing the safety message to new drilling rig employees with its 20-hour orientation program. The support continues through classroom and field training programs. Examples of on-going training include technical support in gas detection, confined-space training, fall protection, well control and environmental spill response.

Precision encourages safe behaviour and develops leaders through its two-day Observation and Communication workshop. Each year Precision focuses on improving its existing safety programs – in the classroom and in the field.

Precision's *Down to Earth* values list safety as one of the unquestioned company values but the reference does not end there. Precision's values also state that employees are empowered to effect change. Nowhere is that more important than around safety. Precision expects all of its employees to be leaders in promoting a culture of safety.

For 2007, Precision will build on the successes of its safety performance through its *Down to Earth* values. As stated earlier in the Executive Chairman's message "Times will change but values endure". For Precision, there is no more enduring value than the commitment to the health and safety of its people.



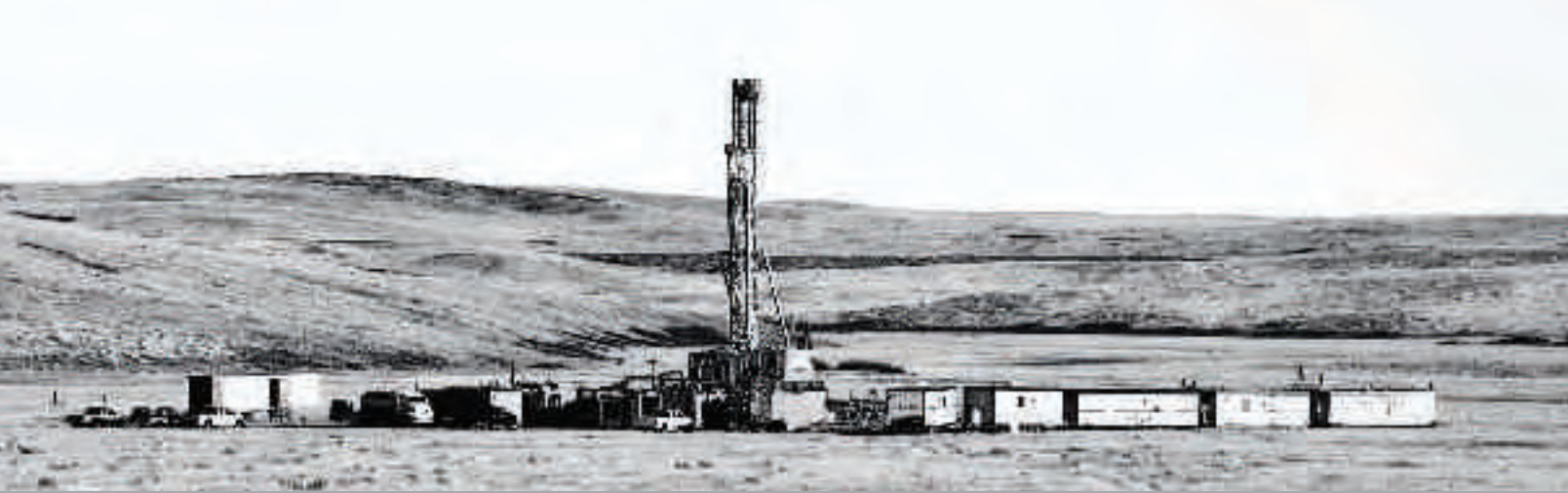

Down to Earth | ENVIRONMENT AND COMMUNITY

ENVIRONMENT

Precision takes a consistent approach to environmental management and has developed systems to ensure it meets or exceeds environmental standards. Precision's investment in environmental management begins with equipment design and upgrade, for example:

- rigs are designed with a small footprint to minimize ground disturbance;
- engine upgrades are made to improve fuel efficiency, reduce emissions and suppress noise;
- surface equipment, including well control, is designed to contain spills and leaks; and
- facilities have secondary containment for above ground storage compartments and environmental spill response equipment and supplies.

The investment in 2006 to acquire Terra Water Systems provided Precision with the ability to deliver wastewater treatment services at remote locations to reduce the environmental impact of oil and gas activity.

For Precision, environmental incidents are reported, investigated, analyzed and followed-up with appropriate remedial response. Quarterly reports are submitted to senior management and the board of directors. Precision initiated an environmental site assessment for each of its divisions and expects a completed report on all properties in 2007.

To meet its commitments, Precision has developed environmental expertise in-house with a focus toward:

- improving environmental management systems;
- field awareness and training;
- conducting environmental compliance audits;
- maintaining a high level of housekeeping standards on equipment and at facilities;

- environmental review during management field visits; and
- timely reporting and remedial measures.

Environmental protection is a key component of Precision's broader commitment to the health and safety of its employees and *Down to Earth* strategy.

COMMUNITY RELATIONS

Precision believes in creating a positive impact in the community by "giving back" with an emphasis on charities that are important to its employees and customers.

In 2006, Precision offered financial support to many areas of need including arts, education, health, community, sports, youth and the environment. Precision proudly sponsors a number of events each year that provide proceeds to charitable organizations and funds for cultural and environmental conservation. To provide ongoing support for organizations, certain donations are made over a three or five-year period, including to organizations such as STARS (the Shock Trauma Air Rescue Society).

Precision hosts an annual corporate United Way Campaign that yields generous support from the company and its employees. Precision employees regularly demonstrate a commitment to their communities through their participation as volunteers for local charities, fundraising events and coaching youth.

Precision also recognizes the value of post-secondary education and provides opportunities for children of its employees through the "Employees' Dependent Scholarship Program." These scholarships are awarded to applicants pursuing studies at universities, colleges and technical or arts facilities and who demonstrate superior academic performance, work experience and community leadership.



Down to Earth | CORPORATE GOVERNANCE

Precision Drilling Trust (the “Trust”) was created by a declaration of trust dated September 22, 2005 and is governed by a board of trustees comprised of three members. The board of trustees has delegated a number of its duties to Precision Drilling Corporation (the “Corporation”), administrator of the Trust. The Corporation is governed by a board of ten directors and managed by our executive management team. Our investors hold units of the Trust or, if eligible to do so, Class B Limited Partnership units of Precision Drilling Limited Partnership (“PDLP”), a subsidiary of the Trust, whose units are the economic equivalent of, and exchangeable on a one-for-one basis into, units of the Trust. Holders of units of the Trust and PDLP are herein referred to as “unitholders”.

At Precision, corporate governance means more than simply complying with a code. We believe that a strong culture of corporate governance and ethical behavior in decision-making is fundamental to the way we do business. We therefore keep a close eye on best practices and constantly develop and improve our own governance framework accordingly. Throughout 2006 we continued to enhance our focus on good corporate governance by building on our existing practices.

Some examples of the Trust’s governance include:

- 100% of the trustees of the Trust are independent (3 out of 3);
- 90% of the directors of the Corporation are independent (9 out of 10);
- All members of the audit, compensation, and corporate governance and nominating committees are independent;
- An independent director serves as the lead director of the board of directors;
- The independent members of the board of directors meet regularly without the presence of management;
- The board of directors oversees and approves the annual strategic plan;
- The board of directors’ committees and chairs operate under written charters setting out their responsibilities;
- The Trust has unit ownership guidelines for trustees, directors, officers and senior management;
- The Trust has a joint code of business conduct and ethics policy to ensure that matters are handled ethically and with integrity;
- The board of directors conducts an annual self-evaluation to determine whether it and its committees are functioning effectively;
- The Trust has a whistleblower hotline to facilitate anonymous reporting of any questionable activities; and
- The Trust continues to evaluate best practices in corporate governance and incorporate those that are in the best interests of unitholders.

The Trust’s corporate governance structures, systems and practices conform with the applicable governance rules and guidelines established by the Canadian Securities Administrators and the United States Securities and Exchange Commission. The units of the Trust are listed for trading on the Toronto Stock Exchange and the New York Stock Exchange.

A complete description of the Trust’s corporate governance practices is set out in the Trust’s 2007 Information Circular which will be available online in April 2007 on Precision’s website at www.precisiondrilling.com.



Frederick W. Pheasey
Director

Brian A. Felesky
Director

Stephen J.J. Letwin
Director

Allen R. Hagerman
Director

Hank B. Swartout
*Executive Chairman
and Director*

Down to Earth | TRUSTEES AND DIRECTORS

W.C. (MICKEY) DUNN⁽²⁾⁽³⁾ Edmonton, Alberta
Director

Mr. Dunn is the Chairman of the Board of True Energy Trust, a founding shareholder and director of Rentcash Inc., a director of Vero Energy Inc. and a director of Cork Exploration Inc. Previously, Mr. Dunn was President and Chief Executive Officer of Cardium Service and Supply Limited, Cardium Tool Services Inc. and Colorado Silica Sand Inc. He has been a Director of Precision since September 1992.

BRIAN A. FELESKY⁽³⁾ CM, Q.C. Calgary, Alberta
Director

Mr. Felesky is counsel to Felesky Flynn LLP, a law firm specializing in tax and trust law. Mr. Felesky is a Co-Chair, Homefront (a domestic abuse charitable organization), Vice-Chair Canada West Foundation, a member of the Senate of Athol Murray College of Notre Dame, a board member of the Calgary Stampede Foundation and the Calgary Arts Development Authority. Mr. Felesky also serves on the Board of Suncor Energy, Inc., EPCOR Power LP, Fairquest Energy Limited and Resin Systems Inc. He has been a Director of Precision since December 2005.

ROBERT J.S. GIBSON⁽¹⁾⁽³⁾ Calgary, Alberta
Trustee and Director

Mr. Gibson has been President of a private investment firm, Stuart & Company Limited, since 1973 and is also Managing Director of Alsten Holdings Ltd. He has been a Director of Precision since June 1996 and was appointed to the Board of Trustees in September 2005.

ALLEN R. HAGERMAN Cochrane, Alberta
Director

Mr. Hagerman currently holds the position of Chief Financial Officer, Canadian Oil Sands Limited. Mr. Hagerman is a member of the Canadian Institute of Chartered Accountants. He also serves on the Board of Syncrude Canada Limited and EPCOR Power LP. Mr. Hagerman has been a Director of Precision since December 2006.

STEPHEN J.J. LETWIN Houston, Texas
Director

Mr. Letwin currently holds the position of Executive Vice President, Gas Transportation and International, Enbridge Inc. Mr. Letwin also serves on the Board of Mancal Corporation, Gaz Metropolitan, Enbridge Energy Partners, Interstate Natural Gas Association of America (INGAA), Canadian Gas Association (CGA) and the C.D. Howe Institute. He has been a Director of Precision since December 2006.



W.C. (Mickey) Dunn
Director

H. Garth Wiggins
Trustee and Director

Robert J.S. Gibson
Trustee and Director

Patrick M. Murray
Trustee and Director

Robert L. Phillips
Director

PATRICK M. MURRAY⁽¹⁾ *Dallas, Texas*
Trustee and Director

Mr. Murray is Chairman and CEO of Dresser Inc., a member of the American Petroleum Institute, the Society of Petroleum Engineers, the board of the World Affairs Council of Greater Dallas, the Valve Manufacturers Association, the Petroleum Equipment Supplier Association, the McGuire Energy Institute and is a director of Houston-based Harvest Natural Resources, Inc. Mr. Murray has been a Director of Precision since July 2002 and was appointed to the Board of Trustees in September 2005.

FREDERICK W. PHEASEY⁽²⁾ *Edmonton, Alberta*
Director

Mr. Pheasey is the founder and continues to be a director of Dresco Energy Services Ltd., which was acquired by National Oilwell, Inc. in 1997. He served as Executive Vice President and a director of National Oilwell, Inc. from 1997 to 2004 and continued to serve on the Board of National Oilwell, Inc. to May 2005. Mr. Pheasey has been a Director of Precision since July 2002.

ROBERT L. PHILLIPS⁽²⁾⁽³⁾ *Vancouver, British Columbia*
Director

Mr. Phillips was most recently President and Chief Executive Officer of BCR Group of Companies from 2001 to 2004. Previously, he was Executive Vice President at MacMillan Bloedel Limited (1999 – 2001), President and Chief Executive Officer of PTI Group Inc. (1998 – 1999) and President and Chief Executive Officer of Dresco Energy Services Ltd. (1994 – 1998). Mr. Phillips has been a Director of Precision since May 2004 and also serves on the boards of several other major Canadian corporations.

HANK B. SWARTOUT *Calgary, Alberta*
Executive Chairman and Director

Mr. Swartout currently holds the position of Executive Chairman of Precision. From November 2005 to December 2006, Mr. Swartout held the position of Chairman and Chief Executive Officer. For the period from 1985 through 2005, Mr. Swartout held the position of Chairman, President and Chief Executive Officer of Precision. Previously, he held positions as Manager of Bawden Western Oceanic Offshore, Vice President of Rig Design and Construction for Dresco, and Manager of Construction for Nabors Drilling Canada.

H. GARTH WIGGINS⁽¹⁾ *Calgary, Alberta*
Trustee and Director

Mr. Wiggins is an Advisor to Investments at Lifewealth and President of a private investment firm, Kamloops Money Management, since 1993. He has been a Principal at Kenway, Mack, Slusarchuk, Stewart Chartered Accountants from 1995 until October 31, 2006. Previously, he was Vice President Finance and Chief Financial Officer of Tri Link Resources Ltd. and a partner of Farvolden, Wiggins, Balderston Chartered Accountants. He has been a Director of Precision since December 1997 and was appointed to the Board of Trustees in September 2005. Mr. Wiggins will not be standing for re-election as a Trustee or Director of Precision in 2007.

(1) Audit Committee Member

(2) Compensation Committee Member

(3) Corporate Governance and Nominating Committee Member



Equipment

Drilling Rig 285 |

Location

West of Didsbury, AB

PERFORMING 8760HRS 52WKS

12:12

Down to Earth | PERFORMANCE

FINANCIAL INFORMATION

Table of Contents

MANAGEMENT'S DISCUSSION AND ANALYSIS

- 31 Overview and Outlook
- 38 Dynamics of the Oilfield Services Industry
- 43 Precision's Development
- 49 Financial Results
- 61 Critical Accounting Estimates,
New Accounting Standards and
Business Risks
- 66 Disclosure Controls and Procedures
- 66 Non-GAAP Measures

FINANCIAL REPORTING

- 67 Management's Report to the Unitholders
- 68 Auditors' Report to the Unitholders
- 69 Report of Independent Registered
Public Accounting Firm
- 70 Consolidated Financial Statements
- 73 Notes to Consolidated Financial
Statements

2006

MANAGEMENT'S DISCUSSION AND ANALYSIS

This Management's Discussion and Analysis ("MD&A"), prepared as at March 9, 2007, focuses on key statistics from the Consolidated Financial Statements, and pertains to known risks and uncertainties relating to the oilfield services sector. This discussion should not be considered all-inclusive, as it does not include all changes that may occur in general economic, political and environmental conditions. Additionally, other events may or may not occur which could affect Precision Drilling Trust (the "Trust" or "Precision") in the future. In order to obtain an overall perspective, this discussion should be read in conjunction with the material contained in other parts of this annual report, including the "Cautionary Statement Regarding Forward-Looking Information and Statements" on page 1, the audited Consolidated Financial Statements and the related notes. The effects on the Consolidated Financial Statements arising from differences in generally accepted accounting principles (GAAP) between Canada and the United States are described in Note 16 to the Consolidated Financial Statements. Additional information relating to the Trust, including the Annual Information Form, has been filed with SEDAR and is available at www.sedar.com.

With the conversion of the continuing assets and businesses of Precision Drilling Corporation to an income trust on November 7, 2005 pursuant to a plan of arrangement, the Trust, as the successor in interest to Precision Drilling Corporation, has been accounted for as a continuity of interest. Commencing with the year ended December 31, 2005 and the comparables for the quarterly and annual periods for the years ended December 31, 2005 and 2004, the Consolidated Financial Statements of the Trust reflect the financial position, results of operations and cash flows as if the Trust had always carried on the business formerly carried on by Precision Drilling Corporation.

HIGHLIGHTS

(Stated in thousands of Canadian dollars, except per diluted unit/share amounts)

Years ended December 31,	% Increase		% Increase		% Increase	
	2006	(Decrease)	2005	(Decrease)	2004	(Decrease)
Revenue	\$ 1,437,584	13	\$ 1,269,179	23	\$ 1,028,488	12
Operating earnings ⁽¹⁾	595,279	28	465,378	40	331,313	31
Earnings from continuing operations	572,512	159	220,848	17	188,131	31
Discontinued operations, net of tax ⁽²⁾	7,077	n/m	1,409,715	n/m	59,273	n/m
Net earnings	579,589	(64)	1,630,563	559	247,404	37
Cash provided by continuing operations	609,744	196	206,013	(28)	286,437	43
Net capital spending from						
continuing operations ⁽³⁾	233,693	67	140,077	23	113,897	34
Distributions declared – cash	447,001	n/m	70,510	n/m	–	–
Distributions declared – in-kind	24,523	n/m	–	–	–	–
Per diluted unit/share information:						
Earnings from continuing operations	4.56	159	1.76	9	1.61	23
Net earnings	4.62	(64)	13.00	516	2.11	29
Distributions declared – cash	3.56	n/m	0.56	n/m	–	–
Distributions declared – in-kind	0.195	n/m	–	–	–	–

(1) Non-GAAP measure. See page 66.

(2) Includes gain on disposition of discontinued operations.

(3) Excludes acquisitions and discontinued operations.

n/m – calculation not meaningful.

FINANCIAL POSITION AND RATIOS

(Stated in thousands of Canadian dollars, except ratios)

Years ended December 31,	2006	2005	2004
Working capital	\$ 166,484	\$ 152,754	\$ 557,311
Working capital ratio	1.8	1.4	2.5
Long-term debt ⁽¹⁾	\$ 140,880	\$ 96,838	\$ 718,850
Total assets	\$ 1,761,186	\$ 1,718,882	\$ 3,852,049
Long-term debt to long-term debt plus equity ⁽¹⁾	0.10	0.08	0.24
Long-term debt to cash provided by continuing operations ⁽¹⁾	0.23	0.47	2.51
Interest coverage ⁽²⁾	74.1	15.9	7.2

(1) Excludes current portion of long-term debt which is included in working capital.

(2) Operating earnings divided by net interest expense.

OVERVIEW AND OUTLOOK

Fiscal 2006 marked a new chapter in Precision's development. During the second half of 2005 there were certain events that changed the course of our company. Precision sold 55% of its asset base, agreed to non-compete provisions restricting certain operational scope to Canada and the United States through August 2008, realized a gain of \$1.3 billion and used the proceeds to eliminate \$0.7 billion in public debt and to return \$2.9 billion in cash and marketable securities to its shareholders. Following these strategic transactions, Precision converted its continuing Canadian operations into an income trust structure, pursuant to shareholder approval, on November 7, 2005.

After more than 50 years of operating as either a private or public corporation with no regular dividends to its owners, Precision commenced 2006 with a new capital structure geared toward the flow-through of cash pursuant to a distribution policy managed by its Trustees. After almost a decade of reinvesting a substantial amount of retained earnings toward growth in international markets and certain downhole technologies, Precision returned to its core business segment, contract drilling, and its dominant market position in Canada.

Prior Period Gains from Major Divestitures

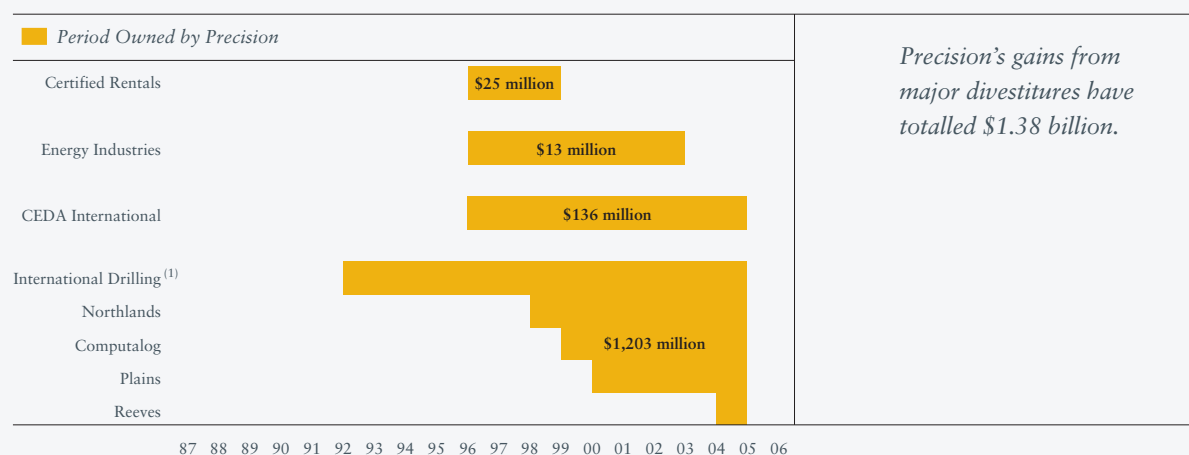

(1) Includes the GlobalSantaFe land drilling asset acquisition in 2004.

The strategy for the continuing business platform in Canada is an affirmation of Precision's prior operational model and for the near term sets the focus on the Canadian marketplace. The emphasis is to build upon our core group of people, augment the services we provide our customers, passionately pursue our Target Zero safety vision and continue to grow and be profitable. Precision set its growth objectives with a view to participate in market opportunities throughout North America with a long-term objective to consolidate higher cost, less efficient competitors and those with a common operational philosophy of providing safe customer solutions through superior technology, process and personnel.

For 2006 this strategy took root with many noteworthy developments.

Profitability

- Precision benefited from strong industry fundamentals carried over from a banner 2005 to generate record earnings from continuing operations for 2006 of \$573 million or \$4.56 per unit.
- Precision generated operating earnings of \$595 million, an increase of \$130 million or 28% over 2005.

Growth

- Net capital spending in 2006 for the purchase of property, plant and equipment increased 67% or \$94 million over the prior year to \$234 million. Before considering proceeds on asset disposals of \$29 million, Precision spent \$92 million toward the productive capacity maintenance of its existing asset base and \$171 million on expansionary initiatives.
 - Precision established a contract drilling operation in the United States and currently operates two rigs.
 - Precision added 13 new and decommissioned two drilling rigs in its Canadian fleet. By the end of the first quarter of 2008, Precision expects to be operating a North American drilling fleet of 260 rigs, 13% more than at the end of 2005.
 - Precision commenced the construction of two service rigs under a long-term customer arrangement, for deployment in the first half of 2007.
 - The snubbing, camp and catering and rental divisions grew existing product lines in response to market conditions.

Augment Customer Services

- On August 17, 2006 Precision acquired a wastewater treatment business for remote work sites which complements our camp and catering and wellsite rental businesses and enhances our level of customer service.

Passionately Pursue Target Zero Safety Vision

- Precision moved closer to its safety vision with a renewed focus on the basic elements of its health, safety and environmental program. The improvement in safe work practices continued for Precision, resulting in a 28% reduction in workplace injuries.

Build Upon Our Core Group of People

- A North American shortage of skilled and experienced oilfield employees carried into 2006. Precision focused on the retention of existing employees through initiatives that provide a safe and productive work environment, opportunity for advancement and added wage security through programs such as our Designated Driller Program.
- The Canadian drilling industry has taken an important step forward with the 2006 commencement of a compulsory journeyman trade program through the Alberta government, the rig technician designation, the first of its kind in the world. Precision has been involved in the development of this initiative from the beginning.
- Precision continued to transition executive roles through a succession process that began in September 2005. Precision announced in October 2006 that its founder, Hank Swartout, would relinquish his position as Chief Executive Officer and assume the role of Executive Chairman effective January 1, 2007. Precision has initiated and continues to develop a more involved strategic planning process.
- Precision completed its internal control certification over financial reporting pursuant to Canadian and United States securities regulations. The initiative was led through internal efforts that sharpened our awareness of the joint code of business conduct and ethics policy and provided numerous opportunities for Precision's management to build upon its skill in identifying and managing risk.

Cash Distributions to Unitholders

- With its conversion to an income trust on November 7, 2005 Precision converted from a cash retention to a cash flow-through model. For 2006, Precision's first full year as an income trust, Precision declared cash distributions of \$447 million or \$3.56 per unit.

- Distributable cash from operations of \$495 million resulted in a cash distribution declared payout ratio of 90% for 2006. This calculation starts with \$610 million in cash provided from operations less \$92 million for productive capacity maintenance capital expenditures and \$23 million for unfunded long-term incentive plan obligations. The remaining \$48 million was retained to fund other investing and financing activities.

In summary, 2006 was a very successful year for Precision. We delivered record-setting financial and safety results through our industry leading market position and operational processes. We generated growth opportunities in our core Canadian market area and we established a new growth platform in the United States drilling market.

In form, our new capital structure as an income trust had an excellent start in 2006. Strong operating cash flow performance led to \$472 million declared distributions to unitholders. At this level, the maximum flow-through potential of Precision's underlying pre-tax income was obtained. The remaining taxable income in the subsidiaries of Precision Drilling Trust led to a 2006 current income tax expense of \$35 million.

By the fourth quarter of 2006, strong business fundamentals were showing clear signs of being eroded as the volatility and declining trend in natural gas pricing slowed customer demand from record levels and downward pressure on pricing for the oilfield service industry was experienced. While customer pricing for Precision has held at record rates, declining demand and the additional supply of new industry equipment resulted in lower utilization to begin 2007 and lower pricing is expected to follow once the seasonal "spring break-up" begins in March. Through the first two months of 2007 drilling rig operating days were 19% lower than 2006 even though Precision's fleet was 5% larger. For Precision's service rig fleet in the Western Canada Sedimentary Basin ("WCSB"), operating hours for the first two months of 2007 were 15% lower.

Deteriorating business conditions in Canada were compounded by the Government of Canada's tax announcements on October 31, 2006 and its clarification regarding normal growth for income trusts on December 15, 2006.

- If the proposed measures are enacted into law, effective January 1, 2011, the current underlying flow-through status of Precision's current income trust structure will be ended. The proposed amendments have negative implications for certain unitholders of Precision commencing in 2011, particularly Canadian tax-exempt investors, foreign investors and tax-exempt entities.
- Nonetheless, Precision's operational business model remains intact.
- Precision originally converted to a trust because the tax rules of the day allowed the market to place a higher value for unitholders on the flow-through structure than the traditional corporate structure. In light of the proposed legislative changes, it is incumbent on the Board of Trustees to examine whether changes in the current legal structure and capital structure are appropriate and in the best interests of unitholders and, if so, when such changes should be implemented.

Monitoring of the current operating environment in North America is also warranted as a significant quantity of new equipment is under construction and Precision's level of customer demand uncertainty is higher than it has been in the past five years. This shift in momentum is not new. Precision operates in the cyclical energy sector and our business model has evolved to ensure that we are in a position to take advantage of opportunities through all stages. Given the competitiveness and inherent risk factors involved, Precision's strategy is patience, flexibility, financial prudence and opportunism.

A strong balance sheet has been a key performance driver for Precision over the years. Low debt levels at the peak and bottom of a cycle enabled Precision to cope with lower operating cash flows and provided the financial leverage to invest in meaningful growth as opportunities arose. The Canadian oilfield service sector has undergone significant growth in equipment supply due to a surge in natural gas well drilling over the past five years. Declining demand conditions in 2007 have created excess drilling rig capacity and a severe drop, or persistent decline in demand, may result in opportunities for industry consolidation.

Historic Levels of Long-term Debt

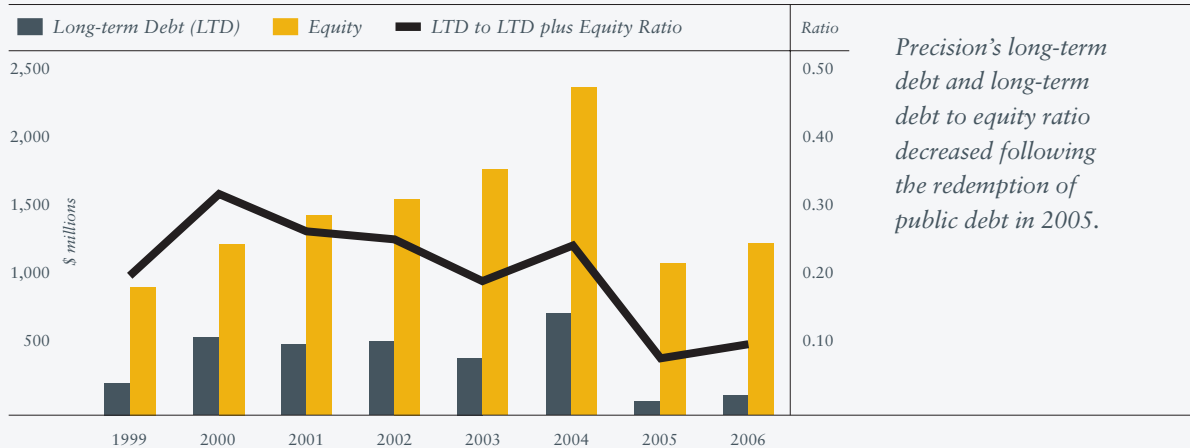

Currently, Precision's financial performance is heavily dependant on industry fundamentals within Canada. These fundamentals are 70% weighted towards natural gas wells and the volatility that exists with seasonal shifts and customer spending associated with the WCSB.

For 2007, Precision's strategy remains focused on opportunities in Canada and the United States and 2006 developments are expected to move Precision forward in a more competitive marketplace.

Precision's growth strategy is to diversify our earnings base so that Precision is active in many of the significant oil and natural gas basins in North America. Our participation in these basins is focused on providing our customers with a level of service and capability that sets our performance apart from the competition. Just as Precision has become a prominent SAGD driller for major projects in Canada's oil sands, our participation in the United States through two drilling rigs is setting the stage for further opportunity.

For the past two years, growth has been achieved through the construction of new drilling rigs. The type of rig being built by Precision is a long-term investment geared toward performance and the lowering of customer well costs. These versatile rigs are of a type and design that is capable of drilling in North America's unconventional resource areas and in many other areas of the world.

The U.S. drilling rig count is about three times larger than Canada's. At present, Precision is a substantial Canadian oilfield service company and the dominant player with 29% and 23% of the drilling and service rig markets, respectively. For Precision, the United States is an untapped growth area that has been renewed by unconventional natural gas production. For the first time in Precision's history, the company is working to establish permanent operations in the United States, a market that today has approximately 2,300 drilling rigs. We are moving in this direction even though we expect rig demand in the United States to moderate. If this occurs, we believe that rigs with poor mobility and old components will find it difficult to compete. This high grading of equipment plays into Precision's operational strategy.

Drilling and service rigs make up approximately 90% of Precision's revenue and have always been the core business platform and areas of expertise for the company. Precision is planning to work within core customer relationships to broaden market opportunities in North America. We are focused on equipment that moves technology and processes forward to minimize costs and enable customers to exploit the full oil and natural gas potential of their land holdings.

SUMMARY OF CONSOLIDATED STATEMENTS OF EARNINGS

(Stated in thousands of Canadian dollars)

Years ended December 31,	2006	2005	2004
Revenue:			
Contract Drilling Services	\$ 1,009,821	\$ 916,221	\$ 727,710
Completion and Production Services	441,017	369,667	313,386
Inter-Segment Elimination	(13,254)	(16,709)	(12,608)
	<u>1,437,584</u>	<u>1,269,179</u>	<u>1,028,488</u>
Operating earnings (loss):			
Contract Drilling Services	473,624	404,385	282,315
Completion and Production Services	163,119	121,643	77,074
Corporate and Other	(41,464)	(60,650)	(28,076)
	<u>595,279</u>	<u>465,378</u>	<u>331,313</u>
Interest, net	8,029	29,270	46,280
Premium on redemption of bonds	–	71,885	–
Loss on disposal of short-term investments	–	70,992	–
Other	(408)	–	(4,899)
Earnings from continuing operations before income taxes	587,658	293,231	289,932
Income taxes	15,146	72,383	101,801
Earnings from continuing operations	572,512	220,848	188,131
Discontinued operations, net of tax	7,077	1,409,715	59,273
Net earnings	<u>\$ 579,589</u>	<u>\$ 1,630,563</u>	<u>\$ 247,404</u>

Revenue and Operating Earnings

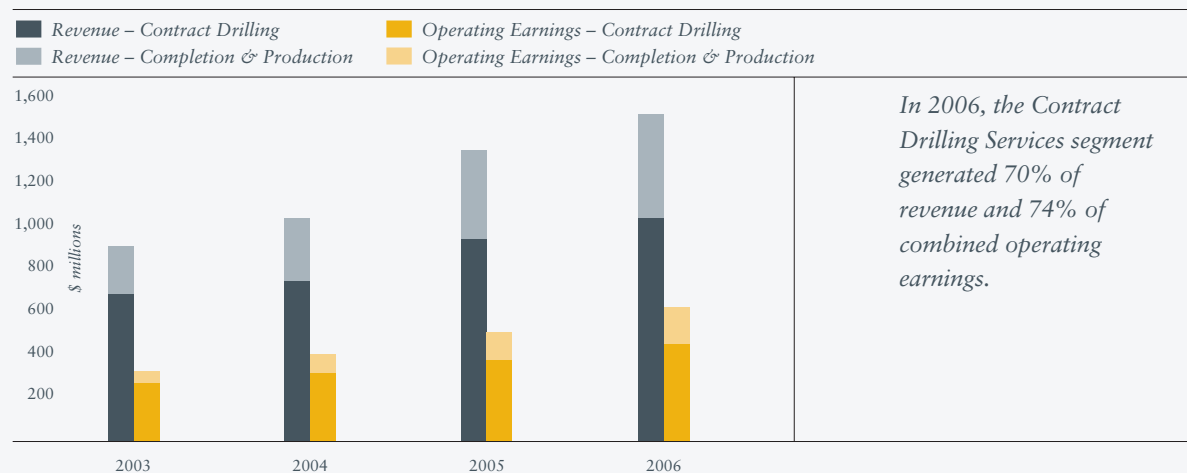

Capital Expenditures for the Purchase of Property, Plant and Equipment

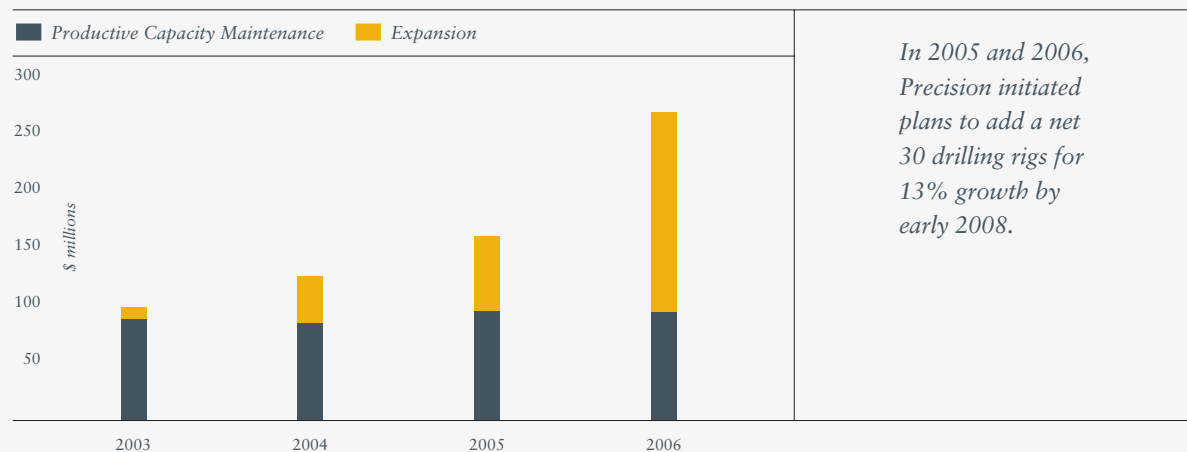

For the year ended December 31, 2006, Precision's earnings from continuing operations were a record \$573 million or \$4.56 per diluted unit compared to \$221 million or \$1.76 per diluted unit in 2005. In the prior year, earnings from continuing operations were reduced by one-time charges of \$160 million or \$1.04 per diluted unit, net of tax. The lower effective income tax rate as an income trust and enacted tax rate reductions contributed an increase over the prior year of \$1.21 per diluted unit. The remaining increase of \$0.55 per diluted unit was due in large part to pricing and activity strength in the first half of 2006. West Texas Intermediate ("WTI") crude oil averaged US\$66.11 per barrel in 2006 versus US\$56.49 in 2005 and Henry Hub natural gas averaged US\$6.73 per MMBtu in 2006 versus US\$8.95 in 2005.

Natural gas prices in North America peaked in December 2005 at US\$15.39 per MMBtu and declined to about half that level by December 2006. There were 7% fewer wells (22,575) drilled in western Canada from the record in 2005 and only the first quarter showed a year-over-year increase from 2005 drilling.

Despite a decline in wells drilled, the 158,416 industry operating days were slightly higher than 2005 and established a new record for Canada's drilling contractors. Deeper drilling and fewer shallow gas and coal bed methane wells increased the average operating days per well by 8% from 6.5 to 7.0 in 2006.

Higher oil prices and lower gas prices prompted some customers to shift drilling dollars to oil prospects in 2006 which led to the most oil completions since 1997. The increase in well licenses issued for oil targets was not enough to offset a decline in conventional gas permits and an even bigger drop for coal bed methane wells. Oil licenses reached 6,770, the most since 2000, while permits to drill for gas declined 15% to 18,270.

The year ended on a weak note as the spot price for natural gas decreased amid concerns over high gas storage levels and expectations of a warm winter in North America. Oil prices also retreated in the fourth quarter from a record high in July but remained relatively strong. Henry Hub natural gas spot prices ranged from a fourth quarter high of US\$8.45 per MMBtu to a low of US\$3.62 on September 29, 2006, compared to a range of US\$15.39 to US\$8.79 in the same quarter of the prior year. The one-year forward price for North American natural gas weakened to trade in a range of approximately \$6.50 to \$8.50 on Canadian and U.S. exchanges in the quarter. During 2006, the persistent downward trend in commodity prices, natural gas in particular, led to lower demand in the fourth quarter for all of Precision's services in western Canada.

OUTLOOK

The oil and gas industry in Canada lost momentum as 2006 progressed after four years of growth in operating and financial results. The hurricane devastation in the U.S. Gulf Coast in September 2005 created a strong pricing environment for 2006 natural gas drilling activity, however, a persistent downward trend in natural gas pricing adversely affected second half activity levels in the WCSB. The backlog of drilling work quickly depleted and fourth quarter activity was the lowest since 2002.

Fundamentally, we believe there is too much gas in storage in the short term and not enough supply in the long term which should ultimately lead to a recovery in drilling activity.

Clearly, there is negative sentiment toward anticipated drilling levels in 2007. The year is likely to yield far more uncertainty as companies reduce spending because lower cash flows in conjunction with higher finding and development costs are undermining the economics of gas drilling in the WCSB.

Increasingly, Precision's results are driven by the fundamentals for natural gas production and consumption in North America. Moderate gas consumption during the past two winters has left storage levels in the United States trending higher than the five-year average. This has caused natural gas commodity prices to decline and generally customer cash flows have followed, with significant declines reported in the fourth quarter of 2006 as compared to the fourth quarter of 2005. This downward trend has reduced drilling economics and many of Precision's large customers with global operations have reduced their 2007 Canadian drilling budgets.

For 2007, the operating environment for Precision will be challenging. While customer pricing for drilling rigs has held to begin the first quarter, there are signs of market deterioration. For January and February 2007, industry gas well licensing in western Canada is down approximately 30% over 2006. In this same period, Precision's drilling and service rigs have been less active by 19% and 15%, respectively. Customer pricing in the spot market for available equipment is lower than winter 2006/2007 rates. The commissioning of previously announced new equipment will increase industry capacity. With lower 2007 drilling budgets for many of Precision's large customers, Precision will have a higher proportion of its drilling rig fleet available for spot market work than it has had for the previous three years. Further, inflationary pressures from Alberta's strong economy and an active U.S. drilling industry are expected to increase operating costs and maintenance capital expenditures per drilling operating day.

The shallow gas market was the most affected by the slowdown in activity but it also has the potential to recover quickly in response to higher natural gas prices. Deeper drilling programs tend to require more lead time and will typically react more slowly to a recovery in commodity prices.

Drilling activity trends influence well completion work and commodity prices influence the servicing or workover of existing oil and natural gas wells in production. For Precision's service rigs in 2007, reduced drilling rig activity is expected to lower completion work. Early indications are that workovers for conventional oil and heavy oil wells are reasonably firm, however, Precision does not expect this to be enough to compensate for lower activity for producing gas wells.

As of March 9, 2007, the supply and demand fundamentals for North American natural gas are beginning to show cause for optimism. Winter consumption of gas over the first two months of 2007 has lowered United States natural gas storage from prior year levels by approximately 10%. The AECO spot price for Alberta natural gas was 18% higher than a year ago at \$7.44 per Mcf and the NYMEX 12-month strip natural gas price of US\$8.09 was essentially flat.

While these developments are positive, Precision believes it will take time for its customers to realize higher cash flows and increase their drilling and well servicing expenditures over prior year levels. Looking ahead, high natural gas consumption for summer cooling, weather related natural gas supply disruptions in the Gulf of Mexico and a slowing of U.S. gas drilling could have a favourable impact on natural gas commodity prices and result in higher Canadian drilling activity. To the extent that these events are unfavourable, the increasing rate of decline for new producing wells in North America lowers the supply of gas and eventually should result in higher drilling activity.

Precision remains positive on the medium to long term fundamentals for the North American onshore drilling industry. With a strategy to broaden its market presence and diversify into the United States, Precision intends to deploy rigs from its Canadian fleet for core customers to the major producing basins.

As producers struggle to increase output and growth in oil and gas consumption exceeds new supply, capital spending cutbacks will have a material impact on field productivity and set the stage for recovery. With a recovery as early as winter 2007/2008, a continuing trend in deep natural gas plays and expanding in-situ oil sands development, Precision is well positioned with its large, versatile fleet of rigs and support services.

DYNAMICS OF THE OILFIELD SERVICES INDUSTRY

Through this report, management is presenting its views of Precision's business and the industry in which it operates. Understanding the oil and gas industry and the factors that impact demand for oilfield services is important to assess Precision's long-term strategy, opportunities, financial performance and distribution potential.

GLOBAL MARKETS

For more than a century, global economic growth and prosperity has been largely driven by energy consumption. In that time, crude oil and natural gas have proven to be the cheapest and most versatile sources of energy. Oil and its by-products provide fuel for virtually all of the world's automobiles while oil and natural gas are primary fuel sources for generating heat and electricity and are critical building blocks for countless consumer products.

With 6 billion people worldwide and the population expected to rise by another 1.5 billion in the next 20 years, global energy demand is unprecedented and rising. Energy consumption is predicted to rise 50% to 60% by 2030, as illustrated below, with oil, natural gas and coal meeting approximately 80% of demand. World oil consumption is predicted to rise 1.6% in 2007 due largely to growing demand in China, India and other developing countries. Delivering reliable and affordable energy for these fast-growing and upwardly mobile populations is one of the major challenges society faces in this century.

World Marketed Energy Use by Fuel Type, 1980–2030

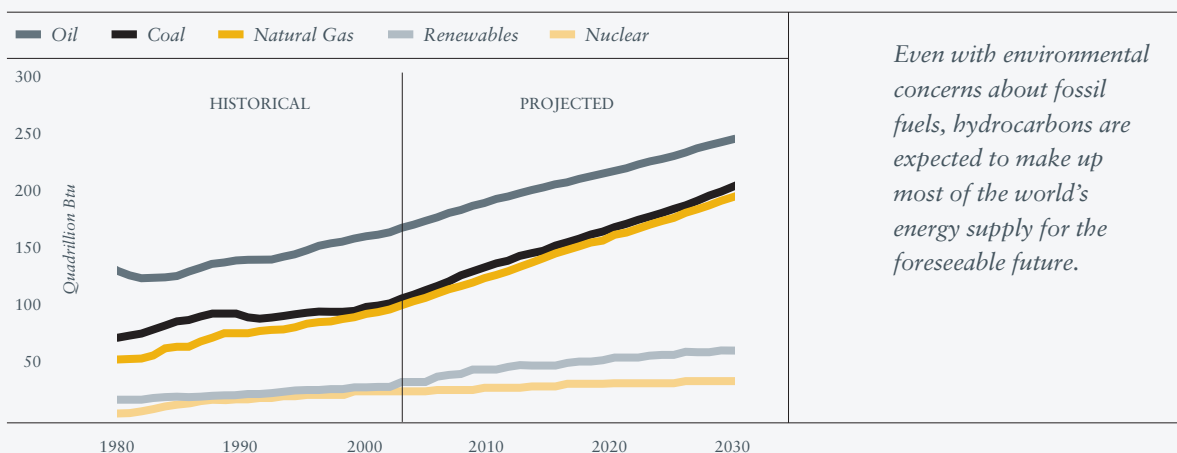

Source: U.S. Energy Information Administration (EIA)

There is growing concern about the connection between burning fossil fuels and climate change. In February 2007, the United Nation's Intergovernmental Panel on Climate Change reiterated calls for action on fossil fuel consumption citing the links to hotter temperatures and rising sea levels. As environmental concerns over carbon dioxide emissions increase, natural gas becomes a more appealing fuel choice, particularly for electricity generation as it is less carbon intensive than traditional fuel sources such as coal. Despite the environmental challenges, crude oil and natural gas are the world's primary energy sources. History has proven it takes decades, if not centuries, to displace energy sources and hydrocarbon production will remain crucial to the world's energy needs for the foreseeable future.

NORTH AMERICAN MARKETS

Economics of the oilfield service industry are aligned with global and regional fundamentals. Important regional drivers for the industry in Canada include the underlying hydrocarbon make-up of the WCSB and the existence of an established, competitive and efficient service infrastructure. Natural gas production increasingly drives economics in the WCSB as approximately 70% of new well completions in 2006 targeted natural gas. Drilling activity in the WCSB is split between the provinces with approximately 75% in Alberta, 15% in Saskatchewan and 10% in British Columbia. Areas of Canada's north hold significant future promise but remain largely untapped frontier opportunities pending government and community support.

The hydrocarbon structure of the WCSB is diverse. Conventional oil and natural gas reservoirs exist at a variety of depths which are comparatively shallow by global standards. These conventional sources are accompanied by more costly and challenging unconventional reservoirs associated with oil sands, heavy oil, coal bed methane and natural gas in deeper, low permeability formations.

A vast natural resource base and next-door proximity to the world’s biggest energy consumer have helped Canada to become the world’s eighth largest oil producer and third largest producer of natural gas. With oil sands development, Canada is one of the few countries with growing petroleum production.

A highly integrated continental energy transportation system and free-market access to U.S. markets has made Canada one of the largest energy providers to the United States. Approximately half of Canadian oil and gas production is exported to the United States.

ECONOMIC DRIVERS OF THE OILFIELD SERVICES BUSINESS

Providing oil and natural gas products to consumers involves a number of players, each taking on different risks in the exploration, production, refining and distribution processes. Exploration and production companies, Precision’s customers, assume the risk of finding hydrocarbons in reservoirs of sufficient size to economically develop and produce. The economics are dictated by the current and expected future margin between the cost to find and develop hydrocarbons and the eventual price of these products. The wider the margin, the greater the incentive to undertake these risks.

Exploration and development activities include acquiring access to prospective lands, seismic surveying to detect hydrocarbon bearing structures, drilling wells and completing successful wells for production. Exploration and production companies hire oilfield service companies to perform the majority of these jobs. The revenue for an oilfield service company is part of the finding and development costs for an exploration and production company.

The economics of an oilfield service company are largely driven by the price of crude oil and natural gas realized by its customers. Since oil can be transported relatively easily, it is priced in a global market influenced by an array of economic and political factors. Natural gas is priced in continental markets due to restrictions on overseas transportation capabilities.

The emergence of liquefied natural gas (“LNG”) is an important new source of supply to North America that could offset production declines from mature reservoirs and help meet rising gas demand. There are still technical, political and environmental challenges for significant LNG developments to occur in North America, but it is widely projected to be a necessary source of supply as demand for natural gas increases.

Over the past two years, rising demand, tight supply and concern over political and weather factors disrupting supply have driven commodity pricing to record levels. The dramatic price rise over a relatively short period has created uncertainty over the sustainability of high cash flows in the industry. Cash flows are critical to replacing production in the upstream sector.

WTI Oil and U.S. Wellhead Natural Gas Price

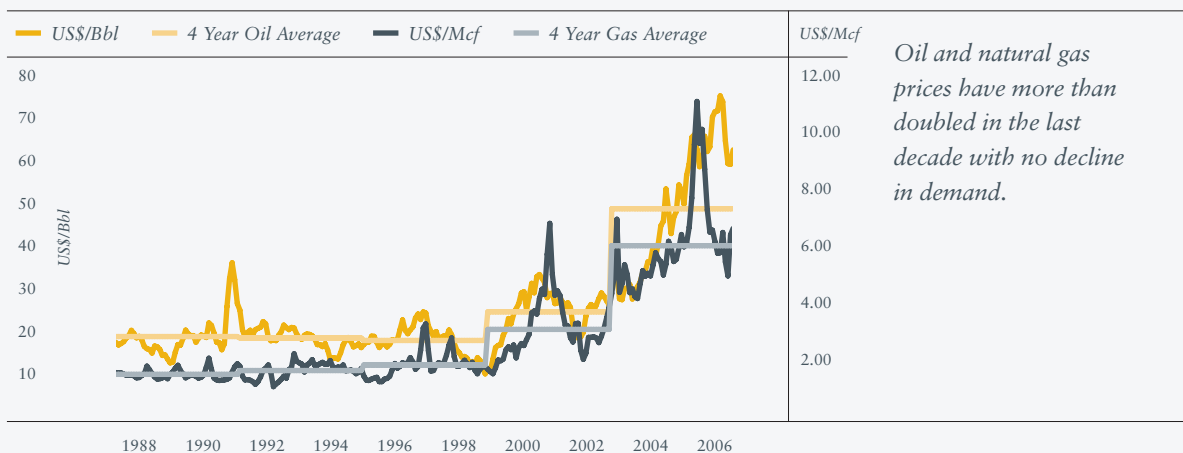

Source: Bank of America, Bloomberg, Reuters, EIA

Oil prices, which rose above US\$78 per barrel in July 2006, are impacted by global factors such as worldwide economic growth, political and social unrest in major producing regions, global weather patterns, policies of the Organization of Petroleum Exporting Countries, commodity market speculation and industrialization in developing countries.

Natural gas, which peaked in North America at US\$15.39 per MMBtu in December 2005, is impacted by factors such as regional economic activity, oil prices, commodity market speculation and, most significantly, the severity of weather in the major population centres across North America.

There is currently a narrow supply-demand balance. Many industry observers believe a new pricing floor is being set due to the combination of production declines and demand growth. New hydrocarbon reserves are clearly more costly and difficult to discover and develop. It has taken record drilling activity over the last three years in North America to maintain overall natural gas production levels. The following illustration demonstrates declines in WCSB new well productivity.

WCSB New Natural Gas Well Productivity

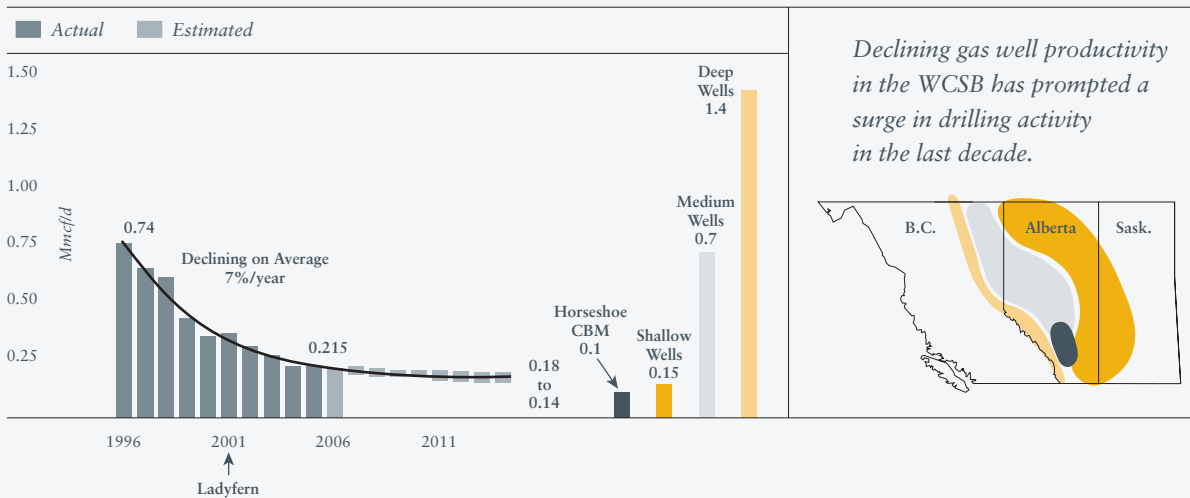

Source: Ziff Energy Group

The graph for western Canada above suggests more wells will be required to meet supply needs. In the WCSB, incremental new gas well production has decreased with the development of shallow gas reservoirs. With record drilling in the last two years (17,769 gas wells in 2005 and 15,640 in 2006) new gas wells only produced an average 215 Mcf per day in 2006 compared with 740 Mcf per day in 1996. In the 1990s the industry drilled approximately 10,000 wells per year in Canada. In this decade the number of wells has averaged approximately 20,000 per year. Natural gas drilling represented approximately 38% of the wells drilled in the 1990s compared to 67% of the wells drilled in the current decade.

Onshore North America is characterized by mature conventional oil and natural gas basins that require substantial activity to maintain or enhance production.

Number of Producing Wells in Western Canada

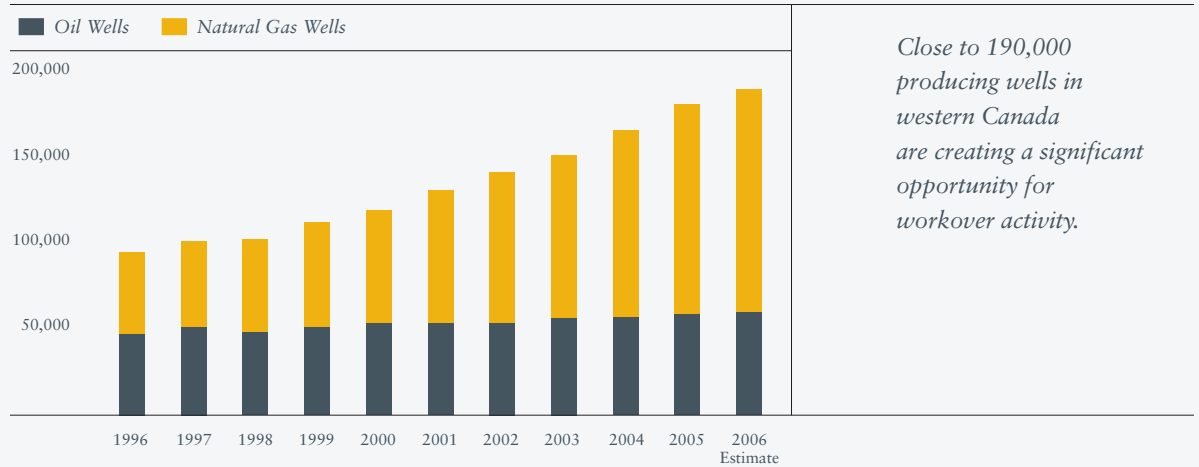

Source: Canadian Association of Petroleum Producers, Precision estimate

Rising energy demand coupled with depletion of conventional resource basins has created an historic shift in the oil and gas industry in North America to develop “unconventional” resources such as oil sands, natural gas in shale and coal bed methane. Unconventional reservoirs tend to be more challenging and expensive to develop than conventional oil and gas reservoirs and generate more service activity. The biggest unconventional resource in Canada is the estimated 179 billion barrels of oil reserves in northern Alberta’s oil sands. There are also large reserves of coal bed methane and shale gas in Canada and the United States. The economics of unconventional resource plays require significant dependence upon technology such as multi-well pad locations, slant drilling rigs and advanced reservoir stimulation techniques.

Reserves to production ratios, which indicate how quickly reserves are depleting, have flattened after a period of decline starting in the 1990s. The result is drilling activity must stay level or increase just to maintain current production and it is leading producers to drill deeper resource plays looking for large gas fields to extend reserve life.

Western Canadian Well Completions vs U.S. Natural Gas Wellhead Price

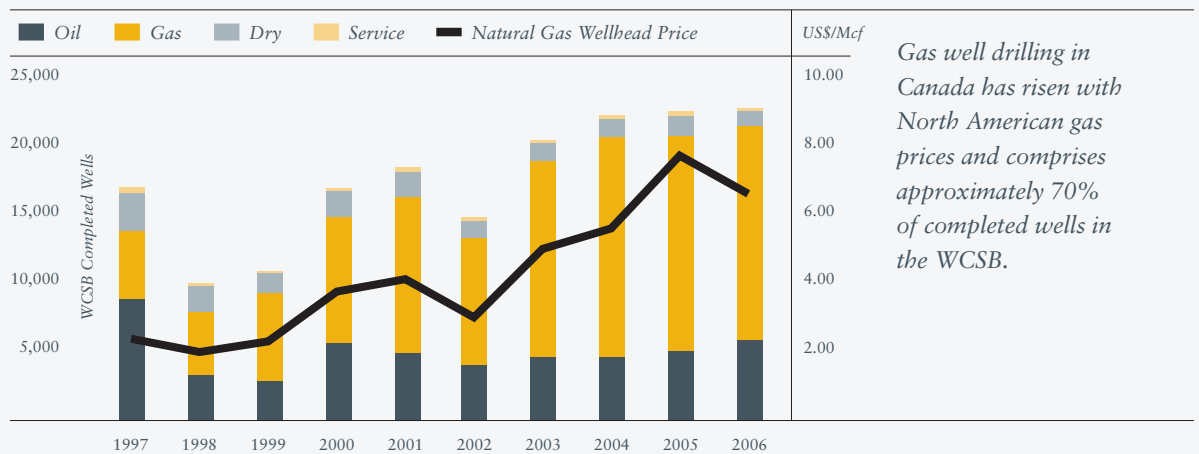

Source: EIA, Canadian Association of Oilwell Drilling Contractors (“CAODC”)

The graph above depicts the increase in natural gas completions over the past 10 years and the correlation to gas pricing. Two successive mild winters have led to high levels of gas in storage and a corresponding decline in price.

With growing energy demand, the supply of drilling rigs in Canada increased steadily over the past 13 years to an all-time high of approximately 850. Customer demand, measured by drilling rig operating day utilization, peaked at 71% in 1997 and has since ranged between 38% and 60%. Industry utilization was 55% for 2006. Higher utilization levels in 2005 and early 2006 prompted drilling contractors to add rigs. Many of the new rigs are telescopic doubles, singles or hybrid coil tubing rigs which are geared to shallow drilling and peak winter demand. In the long term, the larger fleet provides capacity to drill more wells through better year-round utilization. In order to sustain an industry operating day utilization rate of 55%, assuming seven operating days per well and 850 available rigs, there would need to be almost 24,500 wells drilled in the WCSB in 2007. The CAODC is currently estimating that only 19,023 wells will be drilled in 2007.

Active, Marketed and Existing U.S. Drilling Rigs

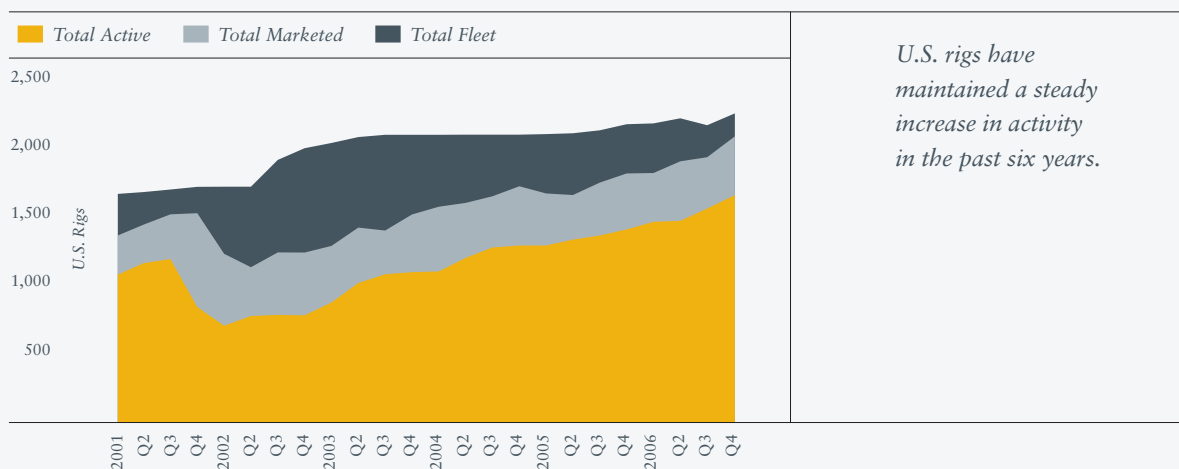

U.S. rigs have maintained a steady increase in activity in the past six years.

Source: RigData and The Land Rig Newsletter compiled by Precision

Active and Existing Canadian Drilling Rigs

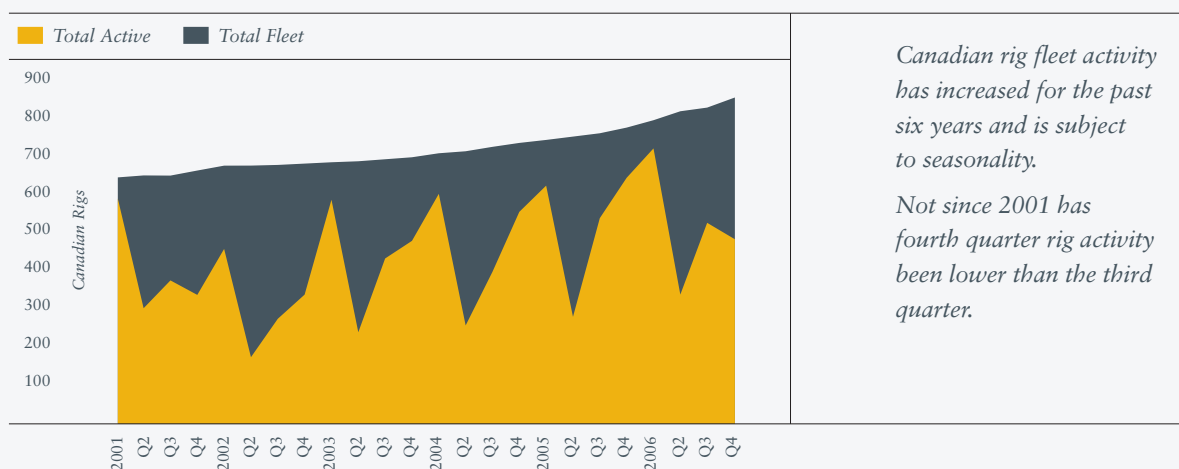

Canadian rig fleet activity has increased for the past six years and is subject to seasonality.

Not since 2001 has fourth quarter rig activity been lower than the third quarter.

Source: CAODC

Approximately 72 drilling rigs were added to the Canadian fleet during 2006, a 9% increase to the total. Despite market softness expected for much of 2007, long-term customer demand to drill conventional oil and gas wells, in combination with improving commercialization of coal bed methane, oil sands and tight gas formations will drive future rig demand.

Just as natural gas is a North American commodity so too are drilling rigs. Many rigs are able to work in Canada or the United States and it is notable that the Canadian drilling rig count is at an all time high and the U.S. rig count is approximately half the capacity of the early 1980s. As illustrated above, Canadian rig activity fluctuates with the seasons, a phenomenon which generally does not occur in the United States.

PRECISION'S DEVELOPMENT

PRECISION'S HISTORY OF CONTINUING OPERATIONS

Precision's history began in western Canada as a land drilling contractor in the 1950s. Through a series of acquisitions over the years, along with organic growth in its service lines, Precision has established itself as Canada's largest oilfield services provider.

Precision Drilling Corporation was founded in 1985 as Cypress Drilling Ltd. and grew from four drilling rigs to 19 with the reverse takeover in 1987 of Precision Drilling Ltd., the company originally formed in 1952.

In the decade following the takeover, a series of acquisitions expanded Precision's Canadian drilling fleet to 106 rigs. With the acquisition of Kenting Energy Services Inc. in 1997, Precision essentially doubled its fleet to 200 rigs representing approximately 40% of the drilling fleet in Canada. The acquisitions of coil tubing drilling rigs and other shallow drilling rigs in 2000 rounded out the drilling rig fleet. Today, after strategic new rig builds and decommissioning, Precision's 240 drilling rigs in Canada comprise approximately 29% of the market.

To support the expanded rig fleet Precision acquired a number of complementary businesses. In 1993, Precision entered the camp and catering business with the acquisition of LRG Oilfield Services Ltd. Along with camps from the drilling rig business acquisitions and the purchase in 2003 of McKenzie Caterers (1984) Ltd., this division now has 101 camps. In 1996, Precision added in-house capabilities for the design, fabrication and maintenance of rig components with the acquisition of Rostel Industries Ltd. The acquisitions of Columbia Oilfield Supply Ltd. and a number of other oilfield equipment companies followed in 1997.

Diversification into businesses that would become Precision Well Servicing, Live Well Service and Precision Rentals began in 1996 with the acquisition of EnServ Corporation that set the stage for a broadened asset base and future growth. In 2000, Precision became fully vested in the Canadian service rig business with the acquisition of CenAlta Energy Services Inc. to create a combined fleet of 257 service rigs and an industry-leading market share of 28%. Today, Precision has 237 service rigs and 26 snubbing units that account for approximately 23% and 30% of their respective markets. Through additional acquisitions in the late 1990s the rental businesses grew and in 2002 were combined and branded as Precision Rentals. In 2006, Precision expanded into the business of remote work site wastewater treatment with the acquisition of Terra Water Group Ltd.

Rig Growth through Acquisition

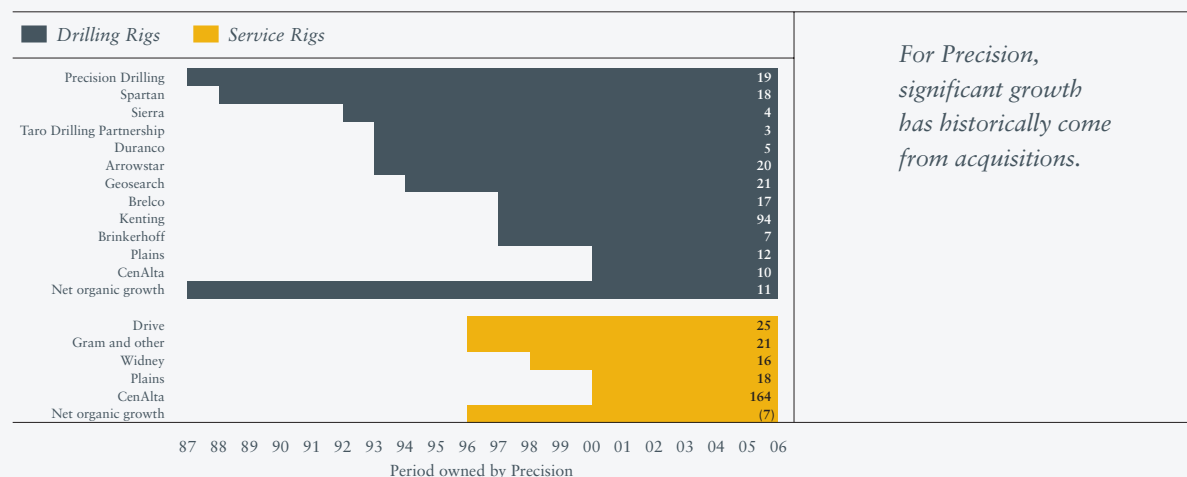

STRATEGIC DIRECTION

Precision is tightly integrated in terms of operations, safety, engineering, information technology, accounting and senior management. Each segment has experienced asset growth and performs a lead market role. Communication is a skill that has been refined and ingrained in Precision's operating culture while continuously focusing on safety initiatives to eliminate workplace incidents. These attributes provide Precision with the ability to pursue the following strategic initiatives as key factors in maximizing the value proposition for its unitholders:

- maintain a flexible business that is responsive to market conditions;
- exploit technological advances where markets dictate;
- focus on organic growth opportunities to enhance and diversify service offerings;
- capitalize on strategic and accretive acquisitions both geographically and operationally;
- develop and enhance employee safety, recruitment and retention initiatives;
- upgrade equipment with customer needs and regulatory requirements in mind; and
- apply operational and financial discipline throughout all areas of the business.

KEY PERFORMANCE DRIVERS

Customer economics are dictated by the current and expected margin between the price at which hydrocarbons are sold and the cost to find and develop those products. Some of the key business, customer and industry indicators that Precision focuses on to monitor its performance are:

Commodity Prices: Precision monitors the spot and forward prices for oil and natural gas as these prices impact customer cash flow and funds for capital programs which govern land acquisition, well licensing and future drilling, and well servicing activities.

Customer Demand: Precision matches the availability of its equipment with customer budgets and drilling programs. Precision's fleet is geographically dispersed to meet customer demands. Relationships with its customers, industry knowledge and new well licenses provide Precision with the necessary information to evaluate its marketing strategies. Industry rig utilization statistics are tracked to evaluate Precision's performance against competitors.

Workforce: Precision's employees are its most important asset. Precision closely monitors crew availability for field operations. Precision focuses on initiatives that provide a safe and productive work environment, opportunity for advancement and added wage security through programs to retain employees. Target Zero reinforces Precision's safety vision and safety statistics are used to benchmark its performance. Precision relies heavily on its safety record to attract new employees.

Operating Efficiency: Precision's revenue is a component of an oil and gas company's finding and development costs. Precision maximizes the efficiency of its operations through its proximity to work sites, its operating practices and its versatility. Precision's reliable and well maintained equipment minimizes downtime during operations. These factors contribute to lower customer well costs.

Financial Performance: Precision maximizes revenue without sacrificing operating margins. Key financial information is unitized on a per day or per hour basis and compared to established benchmarks and past performance. Precision evaluates the relative strength of its financial position by monitoring its working capital and debt ratios. Low debt levels have allowed Precision to manage the cyclical nature of the industry and provide the financial leverage to invest in meaningful growth opportunities.

Expansion Capital Spending: Precision evaluates growth opportunities based on internally established rate of return targets. New drilling rig expansion is typically based on predetermined activity levels over a fixed term operating contract.

OPERATING SEGMENTS

Precision is divided into two operating segments to effectively manage its business, Contract Drilling Services and Completion and Production Services.

The Contract Drilling Services segment is comprised of the following:

- Precision Drilling which provides land drilling services utilizing 240 drilling rigs, approximately 29% of the Canadian industry;
- Precision Drilling Oilfield Services, Inc. which provides land drilling services in the United States and established operations in June 2006 with one rig;
- LRG Catering which supplies camp and catering services with 101 camps, approximately 16% of the industry;
- Rostel Industries which provides engineering, machining, fabrication, component manufacturing and repair services for drilling and service rigs; and
- Columbia Oilfield Supply which provides centralized procurement, standardized product selection, and coordinated distribution of goods for Precision's operations.

The Completion and Production Services segment is comprised of the following:

- Precision Well Servicing which provides well completions and workovers with 237 rigs, approximately 23% of the industry service rigs;
- Live Well Service which performs well completions and workovers with 26 snubbing units, approximately 30% of the industry;
- Precision Rentals which supplies approximately 15,000 rental equipment items including well control equipment, surface equipment, specialty tubulars and wellsite accommodation units representing approximately 10% of the industry; and
- Terra Water Systems Limited Partnership which operates 51 wastewater treatment units, representing approximately 10% of the industry.

Precision Drilling

The following table lists the drilling depth capability of Precision's and industry's Canadian drilling rigs in the WCSB as at December 31, 2006:

Type of Drilling Rig	Maximum Depth Rating (metres)	Precision Fleet			Industry Fleet ⁽¹⁾		
		Number of Rigs	% of Total	% Market Share ⁽³⁾	Number of Rigs	% of Total	Change ⁽⁴⁾
Single	1,200	14	6	10	145	17	21
Super Single™ ⁽²⁾	3,000	28	12	85	33	4	9
Double	3,000	94	39	26	364	43	20
Light triple	3,600	44	18	38	117	14	3
Heavy triple	6,700	49	20	42	118	14	11
Coiled tubing	1,500	11	5	17	65	8	8
Total		240	100	29	842	100	72

(1) Source: Daily Oil Bulletin – Rig Locator Report as of January 2007. Precision has allocated the industry rig fleet by rig type.

(2) Super Single™ excludes single rigs that do not have automated pipe-handling systems, or do not have a self-contained top drive, or cannot run range 3 drill pipe/casing.

(3) Market share means Precision's rigs as a percent of the industry's rigs.

(4) Change in number of industry rigs as compared to the prior year.

The table below summarizes the capabilities of Precision Drilling's North American drilling rig fleet for the past four years:

Type of Drilling Rig	Maximum Depth Rating			2006	2005	2004	2003
	Metres	Feet	Horsepower				
Single	1,200	4,000	250-300	14	17	16	18
Super Single™	3,000	10,000	400-600	29	21	21	15
Double	3,000	10,000	300-500	94	94	95	96
Light triple	3,600	12,000	500-750	44	44	45	47
Heavy triple	6,700	22,000	1,000-2,000	49	43	41	39
Coiled tubing	1,500	5,000	250-300	11	11	11	10
Total				241	230	229	225

Precision Well Servicing

The configuration of Precision Well Servicing's Canadian fleet for the past four years is illustrated in the following table:

Type of Service Rig	Horsepower	2006	2005	2004	2003
Singles:					
Mobile	150-400	12	17	19	30
Freestanding mobile	150-400	92	88	86	75
Doubles:					
Mobile	250-550	44	44	42	46
Freestanding mobile	200-550	9	8	9	6
Skid	300-860	65	65	67	66
Slants:					
Freestanding	250-400	15	15	16	16
Total		237	237	239	239

CAPACITY TO DELIVER

Precision is a major supplier of services to oil and gas companies and its success is dependant on providing a complement of oilfield services that are cost effective to its customers. Precision prides itself on providing quality equipment operated by highly experienced and well trained crews. Maintaining customer relationships is fundamental to Precision's success and based in large part upon the ability to deliver.

Large Diversified Rig Fleets

Precision's large diverse fleet of rigs is strategically deployed across the most active regions of the WCSB. When an oil and gas company needs a specific type and size of rig in a given area, there is a high likelihood that a Precision rig will be readily available. Geographic proximity and fleet versatility make Precision a premium service provider.

Precision's drilling rigs have varying configurations and capabilities, with drilling depth capacities of up to 6,700 metres. Rig categories where Precision dominates correlate well with future drilling opportunities. Deeper depth rigs target foothills natural gas, while Super Single™ rigs are effective in shallow to medium depths including oil sands and heavy oil drilling.

Precision's service rigs provide completion, workover, abandonment, well maintenance, high pressure and critical sour well work and well re-entry preparation across the WCSB. The rigs are supported by three field locations in Alberta, two in Saskatchewan and one in British Columbia.

Snubbing complements traditional natural gas well servicing by allowing customers to work on wells while they are pressurized and production has been suspended. Precision has two types of snubbing units – rig assist and stand alone. Stand alone units do not require a service rig on site and are capable of snubbing and performing many other well servicing procedures.

Inventory of Ancillary Equipment

Precision has a large inventory of equipment, including portable top drives, loaders, boilers, tubulars and well control equipment, to support its fleet of drilling and service rigs to meet customer requirements. Precision also maintains an inventory of key rig components to minimize downtime due to equipment failures.

In support of drilling rig operations, LRG Catering supplies meals and provides accommodation for rig crews at remote worksites. Terra Water Systems plays an essential role in providing wastewater treatment services for LRG Catering and other camp facilities. Precision Rentals supplies customers with an inventory of 15,000 pieces of specialized equipment and wellsite accommodations.

Industry-leading Safety Program

Safety is critical for Precision and its customers. In 2006, almost 300 rigs and four Precision business units achieved Target Zero, Precision's safety vision for eliminating workplace incidents. Precision is a leader in adopting technological advancements which have made drilling rigs, service rigs and snubbing units safer.

Well-maintained Equipment

Precision consistently reinvests capital to sustain and upgrade existing property, plant and equipment – its productive capacity maintenance.

Productive Capacity Maintenance Capital Expenditures

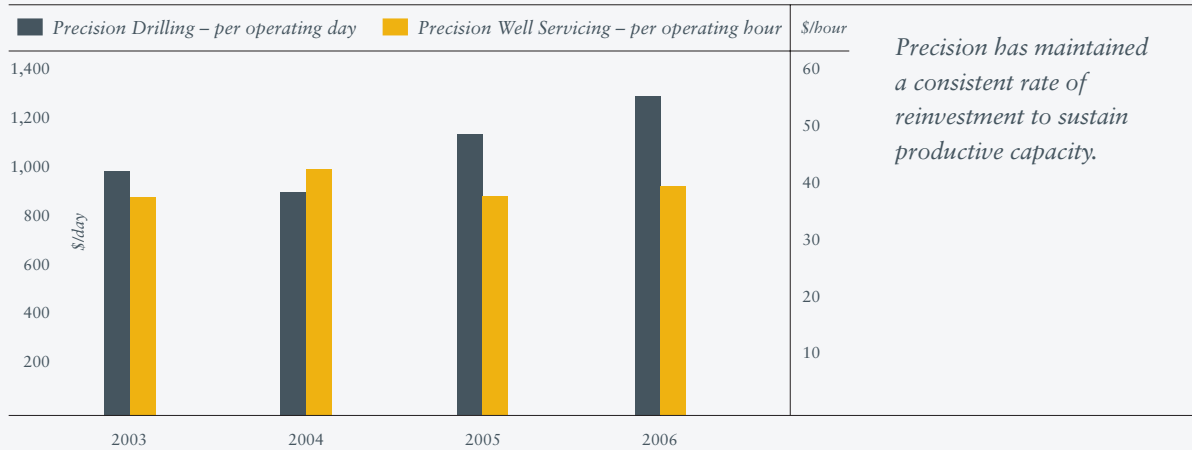

In addition to capital expenditures as illustrated above, equipment repair and maintenance expenses are benchmarked to activity levels in accordance with Precision’s maintenance and certification programs. Precision employs computer technology to track key preventative maintenance indicators for major rig components to record equipment performance history, schedule equipment certifications, reduce downtime and allow for better asset management.

Precision benefits from internal services for equipment certifications and component manufacturing provided by Rostel Industries and for standardization and distribution of consumable oilfield products through Columbia Oilfield Supply.

Employees

As a service company, Precision is only as good as its people. An experienced, competent crew is a competitive strength and highly valued by customers. To recruit rig employees, Precision has centralized personnel departments and orientation and training programs.

Information Systems

Precision’s commitment to invest in a fully integrated enterprise-wide accounting system has improved business performance through real-time access to information across all functional areas of the company. All divisions operate on a common integrated system using standardized business processes across finance, payroll, equipment maintenance, procurement and inventory control.

FINANCIAL RESULTS

CONTRACT DRILLING SERVICES SEGMENT

(Stated in thousands of Canadian dollars, except where indicated)

Years ended December 31,	2006	% of Revenue	2005	% of Revenue	2004	% of Revenue
Revenue	\$ 1,009,821		\$ 916,221		\$ 727,710	
Expenses:						
Operating	470,713	46.6	448,930	49.0	382,886	52.6
General and administrative	27,225	2.7	23,911	2.6	19,190	2.6
Depreciation	38,573	3.8	39,233	4.3	42,245	5.8
Foreign exchange	(314)	–	(238)	–	1,074	0.2
Operating earnings ⁽¹⁾	\$ 473,624	46.9	\$ 404,385	44.1	\$ 282,315	38.8
		% Increase (Decrease)		% Increase (Decrease)		% Increase (Decrease)
Number of drilling rigs (end of year)	241	4.8	230	0.4	229	1.8
Drilling operating days	44,938	(4.3)	46,937	12.8	41,625	(1.5)
Drilling revenue per operating day (\$/day)	20,518	13.8	18,034	9.3	16,494	11.5
Drilling statistics: ⁽²⁾						
Number of wells drilled	6,180	(20.4)	7,766	3.2	7,525	(11.0)
Average days per well	7.2	20.0	6.0	9.1	5.5	10.0
Number of metres drilled (000s)	7,810	(12.3)	8,901	11.0	8,021	(6.8)
Average metres per well	1,264	10.3	1,146	7.5	1,066	4.7

(1) Non-GAAP measure. See page 66.

(2) Canadian operations only.

2006 Compared to 2005

The Contract Drilling Services segment, in 2006, generated record financial results on the strength of improved pricing and the third highest total drilling days in company history. Revenue increased by \$94 million or 10% over 2005 to \$1.0 billion while operating earnings increased by \$69 million or 17% to \$474 million. Operating earnings increased to 47% of revenue in 2006 as compared to 44% in 2005. The operating earnings margin increase was primarily attributable to pricing established in the fourth quarter of 2005 and other pricing increases which held throughout 2006.

Operating costs declined from 49% of revenue in 2005 to 47% in 2006. On a per operating day basis, costs increased slightly due to higher crew wages and cost of materials. Lower equipment utilization increased the per operating day cost associated with fixed operating cost components. Variable costs are controlled through extensive analysis and cost awareness. This combined with the ability to mitigate cost escalations through volume purchasing and relationships with suppliers further enhanced profitability.

The momentum in activity that started to build at the beginning of the third quarter of 2005 continued through the winter drilling season and the start of the 2006 spring break-up. The first half of 2006 was one of the strongest drilling periods on record for the WCSB. However, a persistent downward trend in the natural gas price over the second half of 2006 adversely affected activity levels as the backlog of drilling work quickly depleted and the fourth quarter saw the lowest fourth quarter activity since 2002.

Activity for drilling rigs was down 1,999 operating days, a 4% decline from the prior year. The first half of 2006 showed increases in drilling levels over 2005 with the third quarter only marginally lower due largely to wet weather in September. At the end of the third quarter, Precision was on track to surpass the record drilling activity established in 1997. That would not happen, however, as operators rig released only 5,484 wells in the final quarter of 2006, down 25% from a year earlier.

The decline in natural gas prices contributed to lower active rig counts in the second half of 2006 compared with 2005. Coupled with the expanded industry fleet of 9%, to approximately 842 at year end, the drilling rig operating day utilization fell to 43% in the fourth quarter of 2006 from 68% in the same period of 2005.

During the year, Precision commenced operations in the U.S. land based contract drilling market. In June, Rig 297 was mobilized from the Canadian fleet to Texas to begin work under contract.

Capital expenditures for the Contract Drilling Services segment in 2006 were \$220 million and included \$158 million to grow and expand the underlying asset base and \$62 million to sustain and upgrade existing equipment. The majority of the expansion capital expenditure was associated with new drilling rig construction.

The Precision Drilling division set new financial benchmarks in 2006. Revenue increased by \$73 million or 9% over 2005 to \$919 million. The decrease in activity for 2006 was more than offset by increased rates. Precision commenced 2006 with 170 rigs drilling as operators shortened the Christmas shutdown period to get an early start on winter drilling programs. The first quarter provided the industry with ideal winter drilling conditions as cool temperatures kept the frost in the ground but it was not cold enough to hinder field operations. This unprecedented rig demand and near perfect weather conditions provided an excellent start to the year.

Cold weather in the latter part of March 2006 prolonged the winter drilling season. This enabled rigs to spud late in March and allowed deeper-rated rigs to work into the spring. The first sign of a slowing shallow gas market appeared in the second quarter, particularly with coil tubing and single rigs in southeastern Alberta. The demand for triples was able to offset the shortfall in shallow gas drilling as operating days in the second quarter reached the third highest level in the last 10 years. The triple rig activity in the second quarter was more than 50% higher than the prior year. Strength in the triple rig market at that time reflected customer commitment to deeper gas drilling.

Warm dry weather in western Canada in the third quarter allowed drilling operations to run as scheduled for most of the summer allowing the backlog of wells to be drilled. Drilling days for July and August were 169 days ahead of the previous year's pace going into September 2006. Wet weather in September reduced the rig count and dampened drilling momentum. Precision still reported its third highest activity level in any third quarter in the last 10 years.

Fourth quarter 2006 results were hampered by activity declines attributable to commodity price uncertainties and constraints on customer's 2006 exploration and production budgets. Rising costs and lower cash flows meant many customers had spent their entire 2006 budget by the start of the fourth quarter and they did not move 2007 drilling programs forward. The urgency to put rigs to work diminished as cautious spending developed despite increased rig availability.

Operating earnings in the Precision Drilling division increased by 17% over 2005 due mainly to a 14% increase in the average rate offset by a 5% decline in activity. Depreciation expense for the year was \$3 million higher due to the change in rig mix in the year with increased deep rig activity and new rig builds going into the field. Precision Drilling's cost per operating day increased by 7% mainly due to hourly crew labour rate increases in October 2005 and 2006 of 7% and 4%, respectively. There were also cost escalations for third party labour and materials associated with equipment maintenance programs. An important component of the success of the division is the degree to which cost structures were developed to be as variable as possible with activity levels. This flexibility allowed the division to respond quickly to sudden changes in equipment utilization and produce superior returns in periods of high or low activity.

The Precision Drilling division continued its organic growth strategy with the addition of 13 versatile rigs backed by customer arrangements. Precision spent \$203 million in capital expenditures in 2006, close to twice the spending in 2005.

LRG Catering achieved a new record for activity and revenue in 2006. Activity grew by 11%, while revenue increased 25% due in part to rate increases implemented in the fourth quarter of 2005. Over the first eight months of 2006 activity remained at record levels then slowed in the last four months as commodity prices softened and deeper drilling programs were completed. LRG experienced a higher average day rate as a result of increased base camp activity. LRG is becoming a larger drilling camp and catering provider in western Canada, having expanded its fleet by 10 camps in 2006 to end the year with 101, representing about 16% of the market in western Canada.

Rostel Industries and Columbia Oilfield Supply divisions provided valuable support, best measured by the efficiencies and contributions made to Precision through cost savings. Rostel's expertise provided Precision control over rig construction and enhanced cost control. Columbia is an essential extension of the purchasing process and provided timely, reliable and consistent quality supplies to keep Precision's rigs operating and allowed Precision to standardize product use and quality.

Precision Drilling Oilfield Services, Inc. began operations in the United States in June 2006, with one rig. The rig was active 100% of the time. Growth is planned in the U.S. market through the construction of new rigs and by deploying additional rigs from Canada through customer arrangements.

2005 Compared to 2004

The Contract Drilling Services segment generated record financial results in 2005 on the strength of unprecedented drilling activity in western Canada and improved pricing for related services. The rise in activity strengthened on a comparative quarterly basis year over year for the prior three years. That demand enabled the Contract Drilling Services segment to steadily increase revenue and underlying operating margins.

The segment reported revenues of \$916 million, \$189 million more than 2004, an increase of 26%. These results were generated with an equipment fleet size that was relatively unchanged from the prior year. Revenue growth in 2005 was due to a combination of increased activity and pricing. Operating earnings increased by \$122 million or 43% to \$404 million. Operating earnings increased to 44% of revenue in 2005 as compared to 39% in 2004. The margin increase was primarily attributable to pricing improvements.

Operating expenses declined from 53% of revenue in 2004 to 49% in 2005, and on a per operating day basis, remained flat despite crew wage rate increases. Higher equipment utilization lowered the daily cost associated with fixed operating cost components.

Capital expenditures for the Contract Drilling Services segment in 2005 were \$107 million and included \$54 million to expand the underlying asset base and \$53 million to sustain and upgrade existing equipment. The majority of the expansion capital expenditure was associated with new drilling rig construction.

For the Precision Drilling division revenue increased by \$160 million or 23% over 2004 to \$846 million. Just over half of the revenue growth was due to increased activity and the remainder to increased rates. The division entered the year with great anticipation as rig demand exceeded rig availability by a wide margin. Disappointing activity results for the first half of the year were strictly weather related. These activity levels caused customer drilling programs to fall behind. As ground conditions dried in July, the impact of the pent-up demand led to an outstanding third and fourth quarter in 2005.

Rig demand continued to build momentum through to the end of 2005. Overall, the industry benefited from the pricing leverage established from strong third quarter activity. Accordingly, increased pricing was established in the fourth quarter for the winter drilling season. Rig shortages also created a large spot market for operators who did not have equipment booked for the winter, enabling the division to raise rates.

Operating earnings for the Precision Drilling division increased by 46% due in part to the 13% increase in operating activity combined with the 9% increase in revenue per operating day. Depreciation expense for the year was \$11 million lower due to the effects of a change in the estimated life of rig assets to 5,000 utilization days in 2005 from 4,150 in 2004. Precision Drilling was able to maintain its cost per operating day at its 2004 rate. Crew labour costs in 2005 comprised 52% of operating costs, up 2% from 2004. The 2005 cost of drilling, maintenance and overhead on a per day basis was consistent with 2004.

In the fourth quarter, two Super Single™ Light rigs were added to the fleet and one rig was sold resulting in a rig count of 230 at the end of 2005.

LRG Catering experienced a 26% increase in camp days and a 40% increase in revenue over the prior year. The growing number of field personnel in the industry put overwhelming pressure on other accommodation sources, such as hotels. Customers compensated by utilizing camps in areas where crews would normally have returned to town for lodging. LRG grew its fleet in 2005 by adding five new six-unit camps.

COMPLETION AND PRODUCTION SERVICES SEGMENT

(Stated in thousands of Canadian dollars, except where indicated)

Years ended December 31,	2006	% of Revenue	2005	% of Revenue	2004	% of Revenue
Revenue	\$ 441,017		\$ 369,667		\$ 313,386	
Expenses:						
Operating	231,602	52.5	209,657	56.7	196,113	62.6
General and administrative	14,242	3.2	11,021	3.0	12,708	4.0
Depreciation	32,013	7.3	27,402	7.4	27,508	8.8
Foreign exchange	41	–	(56)	–	(17)	–
Operating earnings ⁽¹⁾	\$ 163,119	37.0	\$ 121,643	32.9	\$ 77,074	24.6
		% Increase (Decrease)		% Increase (Decrease)		% Increase (Decrease)
Number of service rigs (end of year)	237	–	237	(0.8)	239	–
Service rig operating hours	480,137	0.6	477,232	1.1	472,008	7.4
Revenue per operating hour (\$/hour)	712	18.7	600	17.0	513	11.0

(1) Non-GAAP measure. See page 66.

2006 Compared to 2005

The Completion and Production Services segment generated another year of record results on the strength of robust industry activity in western Canada and stronger pricing for services. Improved pricing resulted in a revenue increase of \$71 million or 19% over 2005 to \$441 million while operating earnings increased by \$41 million or 34% to \$163 million. Operating earnings increased to 37% of revenue in 2006 compared to 33% in 2005. The margin increase was mainly attributable to price increases established during the year.

Operating expenses declined from 57% of revenue in 2005 to 53% in 2006, but on a per operating hour basis, increased due to higher crew labour costs and higher costs associated with repair and maintenance.

The number of wells rig released in 2006 was 22,575, a decrease of 7% from the record of 24,351 established in 2005. However, with a lag between the drilling and completion of a well, the industry reported a record 22,171 well completions for the year, an increase of 1% from 21,980 in 2005. The total well count for completions in western Canada was 97,164 for the last five years adding to the ongoing maintenance demand to ensure continuous and efficient operation of producing wells. There are currently about 190,000 producing wells within the WCSB.

Service rig contractors in western Canada have maintained the industry rig fleet count relatively constant over the past several years at approximately 1,050 service rigs as market pricing remained competitive.

The Completion and Production Services segment is also affected by seasonality in Canada. The first and fourth quarters of the year are the most active as colder weather allows for the unrestricted movement of heavy equipment on county and provincial roads. The first quarter traditionally produces the highest utilization as customers are able to work in northern areas that are only accessible at that time.

During 2006, Precision acquired Terra Water Systems, a wastewater treatment business. Terra Water had 41 treatment units at the time of the acquisition and closed the year with 51. The service provided by Terra Water complements those provided by the LRG Catering and Precision Rentals divisions and strengthened the diversity of Precision's services.

Reinvestment in equipment in recent years has helped to position the Completion and Production Services segment as an industry leader. Excluding the business acquisition of Terra Water Systems, capital spending in 2006 was \$39 million, an increase of 11% over 2005. The total included expansion capital of \$13 million for new pump trucks, new slant service rigs, stand alone snubbing unit fabrication, wellsite accommodations, storage tanks and wastewater treatment units. Productive capacity maintenance expenditures of \$26 million were incurred in the year and included replacement pump and transporter trucks, snubbing unit trucks, drill pipe for rental and tanks.

The Precision Well Servicing division increased revenue by \$56 million or 20% over 2005 to \$342 million. Higher rig rates and marginally improved activity levels over the prior year contributed to the higher revenue. Price increases established in the fourth quarter of 2005 were maintained with a slight upward adjustment in the fourth quarter of 2006.

Service rig activity was at record levels for the first three quarters of 2006 due to continued strong industry activity carried over from 2005 and the backlog of new well completions. However, wet weather in September and declining natural gas prices caused customers to reassess natural gas completion and workover programs. Oil well servicing was steady throughout the year as crude oil prices remained above US\$50 per barrel. The strong first half of the year offset the activity decline in the fourth quarter resulting in 2006 exceeding 2005 by 2,905 operating hours, for 56% utilization.

Operating earnings for the division improved by \$36 million, or 41%, over 2005, due mainly to service price increases. Costs per operating hour were higher year over year due to increased crew and rig manager labour expenses and equipment repair and maintenance costs.

Capital expenditures in 2006 were a continuation of long-term plans to upgrade and standardize equipment. Pump trucks, transporters and mobile doghouse replacements were completed primarily to replace aging units. The electronic upgrade of engines to include the latest emission control and fuel conservation standards was also undertaken. Carrier modifications were completed to reduce rig weights for travel during road ban periods. The construction of two new slant service rigs under long-term contract commenced in 2006 and, when commissioned in 2007, will bring the fleet to 239 rigs.

Live Well Service's activity decreased by 14% over 2005 with revenues for the year of \$35 million. The decrease was due to the weakening of natural gas prices in 2006 which led to a cost savings shift by customers away from rig assist and to stand alone snubbing services. Live Well's snubbing fleet consists of 26 units of which 25 are rig assist with one stand alone unit. In the fourth quarter of 2006, construction started on four stand alone units, two under long-term customer contract, which will bring the total snubbing fleet to 30 units in 2007.

Precision Rentals generated revenues of \$62 million, which was \$11 million or 21% higher than in 2005. Each of Precision Rental's three product categories; surface equipment, tubulars and well control equipment, and wellsite accommodations, experienced year over year revenue increases. Total capital expenditures for 2006 increased 26% from 2005 and included 79 tanks and 10 new wellsite trailers.

Terra Water Systems generated revenues of \$2 million for the period subsequent to August 17, 2006. Growth is expected through product and market diversification, leveraging its synergies with LRG Catering's remote camp business and Precision Rental's wellsite accommodations.

2005 Compared to 2004

The Completion and Production Services segment generated revenue of \$370 million, 18% higher than the \$313 million in 2004 with operating earnings increasing by \$45 million or 58% to \$122 million. Operating earnings increased to 33% of revenue in 2005 as compared to 25% in 2004. The margin increase was attributable to the enhanced operating performance of the service rig fleet as the division was able to increase rates throughout the year. Equipment demand provided the ability to establish pricing levels based on possession rather than just usage.

Operating expenses declined from 63% of revenue in 2004 to 57% in 2005 and increased marginally per operating hour due to higher labour costs. Centralization of personnel, accounting, purchasing, and equipment management provided economies of scale and more effective deployment of segment resources.

Capital spending in 2005 was \$35 million, an increase of 9% over 2004. This included expansion capital of \$8 million for a stand alone snubbing unit, additional pump trucks, wellsite accommodations and storage tanks. Maintenance capital included replacement trucks for transporters, snubbing units and pump trucks as well as drill pipe for rental, snubbing equipment and a facility upgrade in Grande Prairie, Alberta.

The Precision Well Servicing division increased revenue by \$44 million or 18% over 2004 to \$286 million due to a slight increase in activity and higher rates. Precision Well Servicing achieved 55% utilization, a nominal improvement over the prior year. Operating earnings improved by \$38 million, a 79% improvement over the prior year due mainly to price increases. In addition, operating costs were marginally higher per operating hour year over year due to higher labour costs. Cost efficiencies were achieved by the consolidation of operating centres in the latter part of the prior year. Capital expenditures in 2005 emphasized the upgrading and standardization of equipment.

Live Well Service's activity decreased slightly in 2005. The demand for snubbing, while finishing strong, slowed early in the year. However, revenue increased by \$4 million or 12% over 2004 to \$32 million. The improvement was attributable to higher hourly operating and standby rates established in the last half of the year. Live Well upgraded its fleet of hydraulic rig assist snubbing units through scheduled truck chassis replacement and introduced its first stand alone unit.

Precision Rentals reported a revenue increase of \$8 million or 19% over 2004 to \$51 million. The increase was attributable to higher drilling activity which led to higher demand and improved pricing for rental equipment. Operating earnings increased by 37% over the prior year. The division expanded its wellsite accommodation fleet in 2005 by 8% with the purchase of 24 units.

OTHER ITEMS

2006 Compared to 2005

Corporate and Other Expenses

Corporate and other expenses decreased by \$19 million or 32% as compared to 2005. Included in the 2005 expenses were \$18 million in costs related to the conversion to an income trust. Excluding these conversion costs, corporate and other expenses decreased \$1 million or 4% year over year. The introduction of the long-term incentive plan ("LTIP") added an additional \$4 million of costs during 2006 over the prior period stock option plan expense, while increased accruals for recurring near-term incentive plans added another \$3 million. Disposals of corporate property, plant and equipment in 2005 and 2006 contributed to a \$2 million reduction in depreciation expense. Significant reductions in Precision's net foreign currency position related to 2005 divestitures and the repayment of U.S. dollar debentures led to a \$3 million reduction in foreign exchange gains in 2006. The remaining \$9 million reduction in costs were mostly attributable to the absence of severance and retention bonuses incurred in 2005, lower legal, advisory and support costs in 2006 and the recovery of certain liability provisions expensed in prior periods.

Interest Expense

Net interest expense of \$8 million declined by \$21 million or 73% in 2006 compared to 2005. This reduction was primarily attributable to the repayment of the outstanding bonds (debentures) in October 2005 which resulted in lower subsequent debt levels. Also in 2005, Precision was in a significant surplus cash position, to the date of trust conversion, which generated \$10 million in interest income. Monthly debt, net of cash, averaged \$164 million in 2006.

Income Taxes

The Trust's effective tax rate, before enacted tax rate reductions, on earnings from continuing operations before income taxes was 6% in 2006 compared to 25% in 2005. This comparatively low effective tax rate was primarily a result of the conversion to an income trust which had the effect of shifting the income tax burden of the Trust to its unitholders.

The Trust incurs taxes to the extent there are certain provincial capital taxes, as well as taxes on any taxable income, of its underlying subsidiaries, not distributed to unitholders. In addition, future income taxes arise from differences between the accounting and tax basis of the operating entities assets and liabilities.

During 2006 the federal and certain provincial governments enacted various reductions to corporate income tax rates. The Government of Canada passed legislation to eliminate the corporate capital tax, reduce the federal income tax rate from 21% to 19% over the next four years and eliminate the federal corporate surtax in 2008. The Province of Alberta reduced the corporate income tax rate by 1.5% effective April 1, 2006. Enacted tax rate reductions resulted in a \$21 million future tax recovery in the second quarter of 2006.

Discontinued Operations

A \$7 million gain, net of tax, on discontinued operations was recorded in 2006. A \$2 million gain was recorded on the final payment of contingent consideration associated with the 2004 disposal of United Diamond Ltd. Gains of \$4 million and \$1 million were recorded for working capital adjustments related to the 2005 disposals of CEDA International Corporation ("CEDA") and the Energy Services and International Contract Drilling divisions, respectively. The 2005 business divestitures contributed \$74 million in net earnings and \$1.3 billion in gains on disposition towards the financial results in fiscal 2005.

2005 Compared to 2004

Corporate and Other Expenses

Corporate and other expenses increased by \$33 million or 116% in 2005 as compared to 2004. Included in these expenses are \$18 million in costs associated with the conversion to an income trust comprising a one-time severance payment of \$13 million to a senior executive and \$5 million in legal, accounting and advisory fees. Excluding those costs, corporate and other expenses increased by \$15 million or 53% year over year of which \$6 million was attributable to a reduction in foreign exchange gains and the remaining \$9 million to severance and retention bonus payments, increased legal and advisory fees related to other internal reorganization activities, examining strategic and financing alternatives, and increased internal and external audit costs to comply with financial reporting requirements.

Interest Expense

Net interest expense of \$29 million declined by 37% in 2005 compared to 2004. This reduction was attributable to the repayment of the outstanding bonds (debentures) in October 2005 and from being in a surplus cash position, to the date of trust conversion, which generated \$10 million in interest income.

Premium on Redemption of Bonds

In October 2005, the outstanding bonds were repaid, resulting in a charge of \$72 million that was absent in 2004.

Loss on Disposal of Short-term Investments

Precision received 26 million shares of Weatherford International Ltd. as part of the consideration for the disposal of the Energy Services and International Contract Drilling divisions. Substantially all of the shares were transferred to shareholders in conjunction with the November 7, 2005 plan of arrangement and a \$71 million loss was incurred.

Discontinued Operations

During the third quarter of 2005, Precision completed two significant business divestitures. These businesses contributed \$74 million in net earnings which have been included in discontinued operations. Combined with the gains on disposition in the amount of \$1.3 billion, discontinued operations contributed net earnings of \$1.4 billion towards the financial results in fiscal 2005. First, Precision disposed of its Energy Services and International Contract Drilling divisions, resulting in an after tax gain of \$1.2 billion. Second, Precision disposed of the industrial services business carried on by CEDA for an after tax gain of \$132 million.

Income Taxes

Precision's effective tax rate on earnings from continuing operations before income taxes was 25% in 2005 compared to 35% in 2004. The decrease in the tax rate was primarily a result of the conversion to an income trust in November 2005 which had the effect of shifting the income tax burden of the Trust to its unitholders.

LIQUIDITY AND CAPITAL RESOURCES

In 2006, strong operating results combined with lower net debt levels provided the Trust with cash flows from operations of \$610 million. Issuances of Trust units through the distribution reinvestment plan and increases in long-term debt and bank indebtedness added \$70 million. An additional \$7 million was provided from the settlement of matters relating to prior year dispositions. Offsetting these sources of cash, the Trust incurred capital expenditures, net of dispositions of capital assets and changes in related non-cash working capital, of \$226 million and spent \$16 million to purchase all the outstanding shares of Terra Water Group Ltd. Total cash distributions paid to unitholders during 2006 were \$445 million.

The Trust exited 2006 with a long-term debt to long-term debt plus equity ratio of 10% and a ratio of long-term debt to cash from operations of 23%.

In the 2005 MD&A, the Trust gave guidance as to the expected 2006 amounts for certain balance sheet and cash flow items. Lower 2006 fourth quarter activity, which resulted in a reduction of \$184 million to the expected working capital and profitability, was the primary factor leading to a positive variance of \$260 million over estimated 2006 cash provided by continuing operations of \$350 million. This positive variance combined with lower net productive capacity maintenance capital expenditures, which includes disposal proceeds of \$29 million, led to long-term debt being \$294 million lower than the \$435 million estimate.

Precision has a number of committed and uncommitted lines of credit available to finance its activities. The committed facilities consist of a \$700 million three-year revolving unsecured credit facility with a syndicate led by a Canadian chartered bank. The borrowing capacity of the facility was increased by \$150 million in 2006 to assist in financing the expansionary growth plans of Precision. The facility matures in November 2009, and is extendible annually with the consent of lenders. The facility has three financial covenants which are tested quarterly: total liabilities to equity of less than 1:1; total debt to the trailing four quarters' cash flow of less than 2.75:1; and total distributions to unitholders of less than 100% of consolidated cash flow, as defined in the credit facility agreement. As at December 31, 2006, Precision was well within the financial covenant levels, and is expected to remain so for 2007. There was \$141 million outstanding under the committed facilities at December 31, 2006. In addition to the committed facilities, Precision also has a number of uncommitted operating facilities which total approximately \$66 million equivalent and are utilized for working capital management and the issuance of letters of credit.

The Corporation's contractual obligations are outlined in the following table:

<i>(Stated in thousands of Canadian dollars)</i>	Payments Due by Period				
	Total	Less Than 1 Year	1 – 3 Years	4 – 5 Years	After 5 Years
Long-term debt	\$ 140,880	\$ –	\$ 140,880	\$ –	\$ –
Operating leases	26,538	7,858	11,371	7,309	–
Long-term incentive plan	22,699	–	22,699	–	–
Total contractual obligations	\$ 190,117	\$ 7,858	\$ 174,950	\$ 7,309	\$ –

The Trust instituted the LTIP in 2006 which compensates officers and key employees through cash payments at the end of a three-year term. The compensation is comprised of two components, a retention award and a performance award. The retention award is a lump sum amount determined at the date of commencement in the LTIP. The retention component is accrued evenly over the three-year term and is estimated to total \$11 million with anticipated payment to occur in March 2009. The performance component is based on the growth in cash distributions measured against a base distribution rate as determined by the Compensation Committee of Precision. The performance component is accrued based on actual distributions compared to target distributions. There is no assurance that the performance component will be paid.

Outstanding Unit Data

	February 28 2007	December 31 2006	December 31 2005
Trust units	125,570,432	125,536,329	124,352,921
Exchangeable LP units	187,492	221,595	1,108,382
Total units outstanding	125,757,924	125,757,924	125,461,303

DISTRIBUTIONS

Upon Precision's conversion to an income trust effective November 7, 2005, the Trust adopted a policy of making monthly distributions to holders of Trust units and holders of exchangeable LP units (together "Unitholders"). Precision has a legal entity structure whereby the trust entity, Precision Drilling Trust, effectively must flow its taxable income to unitholders pursuant to its Declaration of Trust. Distributions may be reduced, increased or suspended entirely depending on the operations of Precision and the performance of its assets, or legislative changes in tax laws by governments in Canada. The actual cash flow available for distribution to Unitholders is a function of numerous factors, including the Trust's: financial performance; debt covenants and obligations; working capital requirements; productive capacity maintenance expenditures and expansion capital expenditure requirements for the purchase of property, plant and equipment; and number of units outstanding. The Trust considers these factors on a monthly basis in determining future distributions. In 2006 cash distributions declared were \$447 million or \$3.56 per diluted unit. In December 2006, a special year-end in-kind distribution, as explained below, payable in Trust or exchangeable LP units (together "Units"), of \$25 million or \$0.195 per diluted unit was declared.

In the event that a distribution is declared in the form of in-kind Units, the terms of the Declaration of Trust and the Limited Partnership Agreement require that the outstanding Units be consolidated immediately subsequent to the distribution. Accordingly, the number of outstanding Units would remain at the number outstanding immediately prior to the Unit distribution. As a result, Unitholders would not receive additional Units and the declared amount of the in-kind distribution would be retained in Precision.

Key factors for consideration in determining actual cash flow available for distribution, in an historical context, are disclosed within the consolidated statements of cash flow. A reconciliation of distributable cash from operations in 2006 is as follows:

<i>(Stated in thousands of Canadian dollars, except per unit amounts)</i>	2006	2005	2004
Cash provided by continuing operations	\$ 609,744	\$ 206,013	\$ 286,437
Less:			
Productive capacity maintenance capital expenditures	(92,123)	(92,214)	(82,014)
Unfunded long-term incentive plan obligation	(22,699)	-	-
Distributable cash from operations (A) ⁽¹⁾	494,922	\$ 113,799	\$ 204,423
Cash retained	(47,921)		
Cash distributions declared (B)	\$ 447,001		
Payout ratio (B)/(A)	90.3%		
Distributable cash from operations per basic and diluted unit	\$ 3.94		

(1) Non-GAAP measure. See page 66.

Fiscal 2006 was Precision's first full year as an income trust. Management believes that any retained cash or payout ratio calculation for prior years would not be meaningful given the Trust's November 2005 conversion.

Productive capacity maintenance capital expenditures allow the Trust to maintain its existing service levels. These expenditures consist of betterments and replacements to existing assets and capitalized costs relating to the underlying support infrastructure. The productive capacity maintenance strategy of Precision also involves costs that are charged directly to the income statement. These costs are related to the scheduled maintenance and certification processes within the various operating divisions. The level of these expenditures is driven by activity levels and can be scaled back in times of low activity without jeopardizing the long-term productive capacity of Precision and its underlying assets.

The Trust maintains a strong balance sheet and has sufficient debt facilities to manage short-term funding needs as well as planned equipment additions. Part of the debt management strategy involves retaining sufficient funds from available distributable cash to finance productive capacity maintenance capital expenditures as well as working capital needs. Planned asset growth will generally be financed through existing debt facilities or cash retained from continuing operations.

<i>(Stated in thousands of Canadian dollars)</i>	2006	2005
Units outstanding	125,757,924	125,461,303
Year end unit price	\$ 27.00	\$ 33.00
Units at market	\$ 3,395,464	\$ 4,140,223
Long-term debt	140,880	96,838
Less: Working capital	(166,484)	(152,754)
Enterprise value	\$ 3,369,860	\$ 4,084,307

Precision carried a long-term debt to unit market value ratio of 4% at December 31, 2006. This represents a slight increase over the 2005 ratio of 2%.

QUARTERLY FINANCIAL SUMMARY

(Stated in thousands of Canadian dollars except per diluted unit/share amounts)

Year ended December 31, 2006	Q1	Q2	Q3	Q4	Year
Revenue	\$ 536,408	\$ 223,569	\$ 349,558	\$ 328,049	\$ 1,437,584
Operating earnings ⁽¹⁾	245,909	74,543	142,431	132,396	595,279
Earnings from continuing operations	224,183	88,303	133,552	126,474	572,512
Per diluted unit/share	1.79	0.70	1.06	1.01	4.56
Net earnings	224,183	88,303	139,667	127,436	579,589
Per diluted unit/share	1.79	0.70	1.11	1.01	4.62
Cash provided by (used in) continuing operations	40,940	339,619	74,952	154,233	609,744
Distributions to unitholders – declared	\$ 101,623	\$ 111,681	\$ 116,785	\$ 141,435	\$ 471,524

Year ended December 31, 2005	Q1	Q2	Q3	Q4	Year
Revenue	\$ 383,407	\$ 157,895	\$ 300,016	\$ 427,861	\$ 1,269,179
Operating earnings ⁽¹⁾	153,020	24,505	111,956	175,897	465,378
Earnings from continuing operations	88,281	9,308	2,382	120,877	220,848
Per diluted unit/share	0.71	0.07	0.08	0.96	1.76
Net earnings	138,518	25,851	1,382,648	83,546	1,630,563
Per diluted unit/share	1.11	0.21	11.00	0.66	13.00
Cash provided by (used in) continuing operations	95,902	116,719	46,978	(53,587)	206,013
Distributions to unitholders – declared	\$ –	\$ –	\$ –	\$ 70,510	\$ 70,510

(1) Non-GAAP measure. See page 66.

The Canadian drilling industry is subject to seasonality with activity peaking during the winter months in the fourth and first quarters. As temperatures rise in the spring, the ground thaws and becomes unstable. Government road bans severely restrict activity in the second quarter before equipment is moved for summer drilling programs in the third quarter. These seasonal trends typically lead to quarterly fluctuations in operating results and working capital requirements.

FOURTH QUARTER DISCUSSION

During 2006, the persistent downward trend in commodity prices, natural gas in particular, led to lower fourth quarter demand for all of Precision's services in western Canada. For the first time in five quarters, Precision's operating results were down from the comparable quarter in the prior year as overall customer demand decreased due to the decline in natural gas prices.

Revenue of \$328 million and operating earnings of \$132 million in the fourth quarter of 2006 represented decreases of 23% and 25% respectively, compared to the same period in 2005. Despite the decline in equipment activity, firm pricing helped maintain operating earnings at 40% of revenue in the fourth quarter of 2006 versus 41% in the fourth quarter of 2005.

Earnings from continuing operations in the fourth quarter of 2006 were \$126 million compared with \$121 million in 2005, an increase of \$0.05 per diluted unit. Adjusted for the impact of one-time charges against the prior year fourth quarter earnings from continuing operations of \$75 million, the current quarter represented a decrease of \$0.48 per diluted unit, or 32%. These one-time charges included \$18 million for the reorganization of Precision into an income trust, \$51 million for the loss on a short-term investment in Weatherford International Ltd., and \$6 million for the repayment of outstanding debentures. Precision realized the benefit of a lower effective tax rate for the full quarter in 2006.

Activity for the quarter was down 33% for drilling rigs and 23% for service rigs from the prior year, consistent with industry declines in the quarter of approximately 25% in the number of wells rig released and the number of rigs working. Drilling rig operating days for the fourth quarter of 2006 were also 18% lower than the third quarter of 2006. Compared to 2005, Canadian industry drilling rig operating days decreased by approximately 27% in the fourth quarter of 2006 to 35,682. Industry wells drilled, on a rig release basis, decreased by 24% to 5,339 and the available rig count increased by 9% to approximately 842 compared to the fourth quarter of 2005. New rig capacity in the industry adversely impacted overall equipment utilization rates.

Contract Drilling Service's segment revenue of \$223 million and operating earnings of \$104 million decreased by 28% and 33%, respectively, in the fourth quarter of 2006 compared to the same period in 2005. The decline in equipment activity was offset somewhat by an increase in average day rates for contract drilling of 8%. LRG experienced an activity decrease, achieving 3,730 camp days for a 39% decline over the prior year.

Completion and Production Service's segment revenue of \$108 million and operating earnings of \$40 million decreased by 13% and 22%, respectively, in the fourth quarter of 2006 compared to the same period in 2005. Precision's service rig operating hours during the fourth quarter of 2006 were 109,737 compared to 142,122 in 2005, a decrease of 23%. Well service rig operating hours were down over the prior year due to the general decline in industry activity related to natural gas. The decline in activity was somewhat offset by an increase in hourly service rig rates of 14% for the fourth quarter year over year. Demand for rental equipment followed downward industry trends and was 15% lower than the prior year. For Precision's snubbing division, activity was down 27% in the quarter over the prior year as a result of lower natural gas well activity.

Operating costs increased from 45% of revenue in the fourth quarter of 2005 to 47% in 2006. The increase was mainly caused by a 13% rise in costs per operating day for contract drilling and 15% per operating hour in well servicing including crew wage increases of 4% implemented in the fourth quarter of 2006. There were also increases in third party labour and material costs. Historically, on October 1, a winter rate adjustment for these costs is passed on to customers. This year, in many cases Precision was unable to increase rates to absorb these costs. In addition, equipment repair and maintenance costs were higher per day and per hour as scheduled equipment maintenance was deferred from earlier in 2006 due to a shortage of maintenance infrastructure. Further, lower activity in the fourth quarter of 2006 contributed to increase fixed operating costs per day in contract drilling and per hour in well servicing.

The Trust's effective income tax rate before enacted tax rate reductions on earnings from continuing operations before income taxes was 3% in the fourth quarter and 6% for the 2006 fiscal year. The comparatively low effective income tax rate was primarily a result of the conversion to an income trust part way through the comparative quarter of 2005 which had the effect of shifting all or a portion of the income tax burden of the Trust to its unitholders.

In the fourth quarter, capital expenditures amounted to \$72 million of which \$44 million was for the construction of new drilling rigs and an additional \$2 million for expansion capital in the Completions and Production Services segment. During the fourth quarter of 2006, four new drilling rigs were released into the field. The remaining \$26 million was spent to sustain and upgrade existing equipment and infrastructure.

Fourth quarter monthly cash distributions declared were \$0.31 per diluted unit for aggregate distributions declared of \$117 million or \$0.93 per diluted unit. A special year-end in-kind distribution of \$25 million or \$0.195 per diluted unit was also declared bringing total declared distributions for the quarter to \$141 million or \$1.125 per diluted unit. The special in-kind distribution was made to minimize debt levels and retain balance sheet strength to fund planned asset growth. The distribution reinvestment plan generated cash of \$4 million and on December 18, 2006 was suspended. Long-term debt decreased by \$25 million during the quarter to \$141 million for a long-term debt to long-term debt plus equity ratio of 10%. Working capital decreased by \$51 million during the quarter to \$166 million as lower activity levels reduced revenue and corresponding accounts receivable, while capital expenditures increased.

CRITICAL ACCOUNTING ESTIMATES, NEW ACCOUNTING STANDARDS AND BUSINESS RISKS

CRITICAL ACCOUNTING ESTIMATES

This Management's Discussion and Analysis of Precision's financial condition and results of operations is based on Precision's consolidated financial statements which are prepared in accordance with Canadian generally accepted accounting principles (GAAP). These principles differ in certain respects from U.S. generally accepted accounting principles, and these differences are described and quantified in Note 16 to the consolidated financial statements.

The Trust's significant accounting policies are described in Note 2 to its consolidated financial statements. The preparation of these financial statements requires that certain estimates and judgments be made that affect the reported assets, liabilities, revenues and expenses. These estimates and judgments are based on historical experience and on various other assumptions that are believed to be reasonable under the circumstances. Anticipating future events cannot be done with certainty, therefore, these estimates may change as new events occur, more experience is acquired and as the Trust's operating environment changes.

Following are the accounting estimates believed to require the most difficult, subjective or complex judgments and which are the most critical to Precision's reporting of results of operations and financial positions.

Allowance for Doubtful Accounts Receivable

Precision performs ongoing credit evaluations of its customers and grants credit based upon past payment history, financial condition and anticipated industry conditions. Customer payments are regularly monitored and a provision for doubtful accounts is established based upon specific situations and overall industry conditions. Precision's history of bad debt losses has been within expectations and generally limited to specific customer circumstances. However, given the cyclical nature of the oil and natural gas industry and the inherent risk of successfully finding hydrocarbon reserves, a customer's ability to fulfill its payment obligations can change suddenly and without notice. In cases where creditworthiness is uncertain, services are provided for cash in advance.

Impairment of Long-lived Assets

Long-lived assets, which include property, plant and equipment, intangibles and goodwill, comprise the majority of Precision's assets. The carrying value of these assets is periodically reviewed for impairment or whenever events or changes in circumstances indicate that their carrying amounts may not be recoverable. This requires Precision to forecast future cash flows to be derived from the utilization of these assets based upon assumptions about future business conditions and technological developments. Significant, unanticipated changes to these assumptions could require a provision for impairment in the future. During the fourth quarter of 2006, Precision completed its assessment and concluded that there was no impairment of the carrying value.

Depreciation and Amortization

Precision's property, plant and equipment and its intangible assets are depreciated and amortized based upon estimates of useful lives and salvage values. These estimates may change as more experience is gained, market conditions shift or new technological advancements are made.

Effective January 1, 2005, Precision changed the useful life of its drilling rigs for purposes of determining depreciation expense to 5,000 utilization days from 4,150 utilization days (3,650 operating days), and its drill strings to 1,500 from 1,100 operating days. Utilization days include both operating and rig move days. This change in accounting estimate has been applied prospectively and resulted in an \$11 million reduction of depreciation expense or \$0.09 per diluted unit for the year ended December 31, 2005.

Income Taxes

The corporate subsidiaries of the Trust use the liability method which takes into account the differences between financial statement treatment and tax treatment of certain transactions, assets and liabilities. The Trust, itself, does not have any significant temporary tax differences. Future tax assets and liabilities are recognized for the future tax consequences attributable to differences between the financial statement carrying amounts of existing assets and liabilities and their respective tax bases. Valuation allowances are established to reduce future tax assets when it is more likely than not that some portion or all of the asset will not be realized. Estimates of future taxable income and the continuation of ongoing prudent tax planning arrangements have been considered in assessing the utilization of available tax losses. Changes in circumstances and assumptions and clarifications of uncertain tax regimes may require changes to the valuation allowances associated with Precision's future tax assets.

The business and operations of Precision are complex and Precision has executed a number of significant financings, business combinations, acquisitions and dispositions over the course of its history. The computation of income taxes payable as a result of these transactions involves many complex factors as well as Precision's interpretation of relevant tax legislation and regulations. Precision's management believes that the provision for income tax is adequate.

During 2006, the Government of Canada released for comment draft legislation which would result in a tax structure for trusts similar to that of corporate entities. If the proposed legislation is implemented, the Trust would be required to recognize, on a prospective basis, future income taxes on temporary differences in the Trust.

Long-term Incentive Plan Compensation

The Trust instituted a long-term incentive plan which compensates officers and key employees through cash payments at the end of a three-year term. The compensation includes two components, a retention component and a performance award. The performance component is based on growth in distributions measured against a distribution rate as determined by the Compensation Committee of Precision. As a result of actual distributions in the subsequent two years, the accrued amount for the performance component may be reduced or increased depending on the actual amounts distributed.

NEW ACCOUNTING STANDARDS

The Canadian Institute of Chartered Accountants issued certain new accounting standards which will be in effect for fiscal years beginning on or after October 1, 2006 for recognition and measurement of financial instruments, disclosure of comprehensive income, and hedge accounting.

- Section 3855, "Financial Instruments – Recognition and Measurement", provides guidance on when a financial instrument must be recognized on the balance sheet and how it must be measured. It also provides guidance on the presentation of gains and losses on financial instruments.
- Section 3865, "Hedges", provides guidance on the application of hedge accounting and related disclosures.
- Section 1530, "Comprehensive Income", requires an entity to recognize certain gains and losses in a separate statement, until such gains and losses are recognized in the statement of income.

The Trust does not expect that the adoption of these standards will have a material impact on the consolidated financial statements.

BUSINESS RISKS

The discussion of risk that follows is not a complete representation. Refer to the “Cautionary Statement Regarding Forward-Looking Information and Statements” on page 1.

Certain activities of Precision are affected by factors that are beyond its control or influence. The drilling rig, camp and catering, service rig, snubbing, wastewater treatment, rentals, and related service businesses and activities of Precision in Canada and the drilling rig, camp and catering and rentals businesses and activities of Precision in the United States are directly affected by fluctuations in the levels of exploration, development and production activity carried on by its customers which, in turn, is dictated by numerous factors, including world energy prices and government policies. The addition, elimination or curtailment of government regulations and incentives could have a significant impact on the oil and gas business in Canada and the United States. These factors could lead to a decline in the demand for Precision’s services, resulting in a material adverse effect on revenues, cash flows, earnings and cash distributions to unitholders. The majority of Precision’s operating costs are variable in nature which minimizes the impact of downturns on its operational results.

Crude Oil and Natural Gas Prices

Precision’s revenue, cash flow and earnings are substantially dependent upon, and affected by, the level of activity associated with oil and natural gas exploration and production. Both short-term and long-term trends in oil and natural gas prices affect the level of such activity. Oil and natural gas prices and, therefore, the level of drilling, exploration and production activity have been volatile over the past few years and likely will continue to be volatile. WTI crude oil prices in 2006 ranged from a low of US\$56 per barrel to a high of US\$78 per barrel. Military, political, weather, economic and other events in certain parts of the world, including initiatives by the Organization of Petroleum Exporting Countries, may affect both the demand for, and the supply of, oil and natural gas. North American petroleum service activity is largely focused on natural gas. In 2006 the natural gas spot price, as measured at Henry Hub, averaged almost US\$7 per MMBtu and ranged from an approximate low and high of US\$4 to US\$10 per MMBtu, respectively. Weather conditions, governmental regulation (both in Canada and elsewhere), levels of consumer demand, the availability of pipeline capacity, storage levels and other factors beyond Precision’s control may also affect the supply of and demand for oil and natural gas and thus lead to future price volatility. Precision believes that any prolonged reduction in oil and natural gas prices would depress the level of exploration and production activity. Lower oil and natural gas prices could also cause Precision’s customers to seek to terminate, renegotiate or fail to honour Precision’s drilling contracts which: could affect the fair market value of its rig fleet which in turn could trigger a write-down for accounting purposes; could affect Precision’s ability to retain skilled rig personnel; and could affect Precision’s ability to obtain access to capital to finance and grow its businesses. There can be no assurance that the future level of demand for Precision’s services or future conditions in the oil and natural gas industry will not decline.

Workforce Availability

Precision’s ability to provide reliable services is dependent upon the availability of well-trained, experienced crews to operate its field equipment. Precision must also balance the requirement to maintain a skilled workforce with the need to establish cost structures that fluctuate with activity levels.

Within Precision, the most experienced people are retained during periods of low utilization by having them fill lower level positions on field crews. Precision has established training programs for employees new to the oilfield service sector and works closely with industry associations to ensure competitive compensation levels and to attract new workers to the industry as required. Many of Precision’s businesses regularly experience manpower shortages in peak operating periods. These shortages are likely to be further challenged by the number of rigs being added to the industry along with the entrance and expansion of start-up oilfield service companies. In the near-term, anticipated declines in activity will offset challenges due to rig expansion.

Business is Seasonal

In Canada, the level of activity in the oilfield service industry is influenced by seasonal weather patterns. During the spring months, wet weather and the spring thaw make the ground unstable. Consequently, municipalities and provincial transportation departments enforce road bans that restrict the movement of rigs and other heavy equipment, thereby reducing activity levels and placing an increased level of importance on the location of Precision's equipment prior to imposition of road bans. The timing and length of road bans is dependant upon the weather conditions leading to the spring thaw and the weather conditions during the thawing period.

Additionally, certain oil and natural gas producing areas are located in sections of the WCSB that are inaccessible, other than during the winter months, because the ground surrounding or containing the drilling sites in these areas consists of terrain known as muskeg. Until the muskeg freezes, the rigs and other necessary equipment cannot cross the terrain to reach the drilling site. Moreover, once the rigs and other equipment have been moved to a drilling site, they may become stranded or otherwise be unable to relocate to another site should the muskeg thaw unexpectedly. Precision's business results depend, at least in part, upon the severity and duration of the Canadian winter.

Technology

Technological innovation by oilfield service companies has improved the effectiveness of the entire exploration and production sector over the industry's more than 140-year history. Drilling time has been reduced due to improvements in drill bits, logging and measurement while drilling tools, as well as innovative changes in other areas such as mud systems and top drives. Precision's ability to deliver services that are more efficient in reducing customer development costs is critical to continued success.

Customer Merger and Acquisition Activity

Merger and acquisition activity in the oil and natural gas exploration and production sector can impact demand for Precision's services as customers focus on internal reorganization activities prior to committing funds to significant drilling and maintenance projects.

Competitive Industry

The oilfield services industry in which Precision operates is, and will continue to be, very competitive. There is no assurance that Precision will be able to continue to compete successfully or that the level of competition and pressure on pricing will not affect its margins.

Capital Overbuild in the Drilling Industry

As at December 31, 2006 there were an estimated 842 industry drilling rigs in Canada, an increase of 9% from December 31, 2005. There is no assurance that the level of demand for drilling rigs in the future will be able to support the size of the current industry drilling rig fleet in Canada. Any decline in demand for drilling services within the services industry, directly or indirectly related to the current drilling rigs available, could also lead to a decline in the demand for Precision's services, resulting in a material adverse effect on Precision's revenues, cash flows, earnings and cash distributions to unitholders.

Tax Consequences of Previous Transactions Completed by Precision

The business and operations of Precision prior to completion of the Plan of Arrangement were complex and Precision has executed a number of significant financings, business combinations, acquisitions and dispositions over the course of its history. The computation of income taxes payable as a result of those transactions involves many complex factors as well as Precision's interpretation of relevant tax legislation and regulations. Precision's management believes that the provision for income tax is adequate and in accordance with GAAP and applicable legislation and regulations. However, there are a number of tax filing positions that can still be the subject of review by taxation authorities who may successfully challenge Precision's interpretation of the applicable tax legislation and regulations, with the result that additional taxes could be payable by Precision and the amount payable could be up to \$300 million. Any increase in Precision's tax liability would reduce the funds available for distributions on Trust units.

Credit Risk

Precision's accounts receivable are with customers involved in the oil and natural gas industry, whose revenues may be impacted by fluctuations in commodity prices. Although collection of these receivables could be influenced by economic factors affecting this industry, management considers the risk of a significant loss due to uncollectible receivables to be remote at this time.

Capital Expenditures

The timing and amount of capital expenditures by Precision will directly affect the amount of cash available for distribution to unitholders. The cost of equipment has escalated over the past several years as a result of, among other things, high input costs. There is no assurance that Precision will be able to recover higher capital costs through rate increases to its customers, in which case cash distributions may be reduced.

Access to Additional Financing

Precision may find it necessary in the future to obtain additional debt or equity financing through the Trust to support ongoing operations, to undertake capital expenditures or undertake acquisitions or other business combination transactions. There can be no assurance that additional financing will be available to Precision when needed or on terms acceptable to Precision. Precision's inability to raise financing to support ongoing operations or to fund capital expenditures or acquisitions or other business combination transactions could limit Precision's growth and may have a material adverse effect upon Precision.

Taxation of Distributions

On October 31, 2006, the Government of Canada announced a Tax Fairness Plan containing its intentions to bring about new tax measures including "a Distribution Tax on distributions from publicly traded income trusts and limited partnerships." The government is proposing a four-year transition period for existing income trusts and limited partnerships whereby the new measures will not apply until their 2011 taxation year. Under the proposals, "flow-through entities" will be taxed more like corporations and their investors will be treated more like shareholders. The proposed new tax measures will impair the flow-through nature of Precision Drilling Trust's current tax structure. If enacted into law, these tax measures would result in a distribution tax to the Trust which will reduce the cash distributed to unitholders by the amount of distribution tax paid.

Environmental

There is growing concern about the apparent correlation between the burning of fossil fuels and climate change. In February 2007, the United Nations Intergovernmental Panel on Climate Change released a report reiterating calls for action on the basis that man-made activities, particularly burning fossil fuels, were very likely behind global warming. The issue of energy and the environment has created intense public debate in Canada and around the world in recent years that is likely to continue for the foreseeable future and could potentially have a significant impact on all aspects of the economy including the demand for hydrocarbons and the resulting lower demand for Precision's services.

DISCLOSURE CONTROLS AND PROCEDURES

EVALUATION OF DISCLOSURE CONTROLS AND PROCEDURES

Disclosure controls and procedures are designed to provide reasonable assurance that information required to be disclosed in reports filed with, or submitted to, securities regulatory authorities is recorded, processed, summarized and reported within the time periods specified under Canadian and United States securities laws. The information is accumulated and communicated to management, including the principal executive officer and principal financial and accounting officer, to allow timely decisions regarding required disclosure.

As of December 31, 2006, an evaluation was carried out, under the supervision of and with the participation of management, including the principal executive officer and principal financial and accounting officer, of the effectiveness of Precision's disclosure controls and procedures as defined under the rules adopted by the Canadian securities regulatory authorities and by the United States Securities and Exchange Commission. Based on that evaluation, the principal executive officer and principal financial and accounting officer concluded that the design and operation of Precision's disclosure controls and procedures were effective as at December 31, 2006.

During the fourth quarter of 2006, there have been no changes in internal control over financial reporting that have materially affected, or are reasonably likely to materially affect, Precision's internal control over financial reporting.

NON-GAAP MEASURES

Precision uses certain measures that are not recognized under Canadian generally accepted accounting principles to assess performance and believes these non-GAAP measures provide useful supplemental information to investors. Following are the non-GAAP measures Precision uses in assessing performance.

Precision's method of calculating these measures may differ from other entities and, accordingly, may not be comparable to measures used by other entities. Investors should be cautioned that these measures should not be construed as an alternative to measures determined in accordance with GAAP as an indicator of Precision's performance.

OPERATING EARNINGS

Management believes that in addition to net earnings, operating earnings as reported in the Consolidated Statements of Earnings and Retained Earnings (Deficit) is a useful supplemental measure as it provides an indication of the results generated by Precision's principal business activities prior to consideration of how those activities are financed or how the results are taxed.

DISTRIBUTABLE CASH FROM OPERATIONS

Management believes that in addition to cash provided by (used in) continuing operations, distributable cash from operations is a useful supplemental measure. It provides an indication of the funds available for distribution to unitholders after consideration of the impacts of capital expenditures to maintain the existing productive capacity of Precision's assets and other operational related funding requirements.

MANAGEMENT'S REPORT TO THE UNITHOLDERS

The accompanying consolidated financial statements and all information in the Annual Report are the responsibility of management. The consolidated financial statements have been prepared by management in accordance with the accounting policies in the notes to the consolidated financial statements. When necessary, management has made informed judgments and estimates in accounting for transactions which were not complete at the balance sheet date. In the opinion of management, the consolidated financial statements have been prepared within acceptable limits of materiality, and are in accordance with Canadian generally accepted accounting principles ("GAAP") appropriate in the circumstances. The financial information elsewhere in the Annual Report has been reviewed to ensure consistency with that in the consolidated financial statements.

Management has prepared Management's Discussion and Analysis ("MD&A"). The MD&A is based upon Precision Drilling Trust's (the "Trust") financial results prepared in accordance with Canadian GAAP. The MD&A compares the audited financial results for the years ended December 31, 2006 to December 31, 2005 and the years ended December 31, 2005 to December 31, 2004. Note 16 to the consolidated financial statements describes the impact on the consolidated financial statements of significant differences between Canadian and United States GAAP.

Management is responsible for establishing and maintaining adequate internal control over the Trust's financial reporting. Internal control over financial reporting is a process designed to provide reasonable assurance regarding the reliability of financial reporting and the preparation of consolidated financial statements for external reporting purposes in accordance with generally accepted accounting principles. Because of its inherent limitations, internal control over financial reporting may not prevent or detect misstatements. Therefore, even those systems determined to be effective can provide only reasonable assurance with respect to financial statement preparation and presentation. Also, projections of any evaluation of effectiveness to future periods are subject to the risk that controls may become inadequate because of changes in conditions, or that the degree of compliance with the policies or procedures may deteriorate.

Under the supervision and with direction from our principal executive officer and principal financial and accounting officer, management conducted an evaluation of the effectiveness of the Trust's internal control over financial reporting. Management's evaluation of internal control over financial reporting was based on the Internal Control – Integrated Framework issued by the Committee of Sponsoring Organizations of the Treadway Commission (COSO). Based on this evaluation, management concluded that the Trust's internal control over financial reporting was effective as of December 31, 2006.

The Trust has documented its assessment of internal control over financial reporting and has made this assessment available to our auditors KPMG LLP. Management's assessment of the effectiveness of the Trust's internal control over financial reporting as of December 31, 2006, has been audited by KPMG LLP, as stated in their report included herein, which expresses an unqualified opinion on management's assessment of the effectiveness of internal control over financial reporting as of December 31, 2006.

KPMG LLP, an independent firm of Chartered Accountants, was engaged, as approved by a vote of unitholders at the Trust's most recent annual meeting, to audit the consolidated financial statements and provide an independent professional opinion.

The Audit Committee of the Board of Directors, which is comprised of three independent directors who are not employees of the Trust, provides oversight to the financial reporting process. Integral to this process is the Audit Committee's review and discussion with management and the external auditors of the quarterly and annual financial statements and reports prior to their respective release. The Audit Committee is also responsible for reviewing and discussing with management and the external auditors major issues as to the adequacy of the Trust's internal controls. The consolidated financial statements have been approved by the Board of Trustees on the recommendation of the Board of Directors of Precision Drilling Corporation and its Audit Committee.



Gene C. Stahl
President and Chief Operating Officer
Precision Drilling Corporation,
Administrator to Precision Drilling Trust
March 9, 2007



Doug J. Strong
Chief Financial Officer
Precision Drilling Corporation,
Administrator to Precision Drilling Trust
March 9, 2007

AUDITORS' REPORT TO THE UNITHOLDERS

To the Unitholders of Precision Drilling Trust

We have audited the consolidated balance sheets of Precision Drilling Trust (the "Trust") as at December 31, 2006 and 2005 and the consolidated statements of earnings and retained earnings (deficit) and cash flow for each of the years in the three-year period ended December 31, 2006. These financial statements are the responsibility of the Trust's management. Our responsibility is to express an opinion on these financial statements based on our audits.

We conducted our audits in accordance with Canadian generally accepted auditing standards. With respect to the consolidated financial statements for the year ended December 31, 2006, we also conducted our audit in accordance with the standards of the Public Company Accounting Oversight Board (United States). Those standards require that we plan and perform an audit to obtain reasonable assurance whether the financial statements are free of material misstatement. An audit includes examining, on a test basis, evidence supporting the amounts and disclosures in the financial statements. An audit also includes assessing the accounting principles used and significant estimates made by management, as well as evaluating the overall financial statement presentation.

In our opinion, these consolidated financial statements present fairly, in all material respects, the financial position of the Trust as at December 31, 2006 and 2005 and the results of its operations and its cash flow for each of the years in the three-year period ended December 31, 2006 in accordance with Canadian generally accepted accounting principles.

We also have audited, in accordance with the standards of the Public Company Accounting Oversight Board (United States), the effectiveness of the Trust's internal control over financial reporting as of December 31, 2006, based on the criteria established in Internal Control – Integrated Framework issued by the Committee of Sponsoring Organizations of the Treadway Commission (COSO), and our report dated February 13, 2007 expressed an unqualified opinion on management's assessment of, and the effective operation of, internal control over financial reporting.

KPMG LLP

Chartered Accountants

Calgary, Alberta

February 13, 2007

REPORT OF INDEPENDENT REGISTERED PUBLIC ACCOUNTING FIRM

To the Board of Directors of Precision Drilling Corporation, as Administrator of Precision Drilling Trust and the Unitholders of Precision Drilling Trust

We have audited management's assessment, included in the accompanying management's report, that Precision Drilling Trust (the "Trust") maintained effective internal control over financial reporting as of December 31, 2006, based on the criteria established in Internal Control – Integrated Framework issued by the Committee of Sponsoring Organizations of the Treadway Commission (COSO). The Trust's management is responsible for maintaining effective internal control over financial reporting and for its assessment of the effectiveness of internal control over financial reporting. Our responsibility is to express an opinion on management's assessment and an opinion on the effectiveness of the Trust's internal control over financial reporting based on our audit.

We conducted our audit in accordance with the standards of the Public Company Accounting Oversight Board (United States). Those standards require that we plan and perform the audit to obtain reasonable assurance about whether effective internal control over financial reporting was maintained in all material respects. Our audit included obtaining an understanding of internal control over financial reporting, evaluating management's assessment, testing and evaluating the design and operating effectiveness of internal control, and performing such other procedures as we considered necessary in the circumstances. We believe that our audit provides a reasonable basis for our opinion.

An entity's internal control over financial reporting is a process designed to provide reasonable assurance regarding the reliability of financial reporting and the preparation of financial statements for external purposes in accordance with generally accepted accounting principles. An entity's internal control over financial reporting includes those policies and procedures that (1) pertain to the maintenance of records that, in reasonable detail, accurately and fairly reflect the transactions and dispositions of the assets of the entity; (2) provide reasonable assurance that transactions are recorded as necessary to permit preparation of financial statements in accordance with generally accepted accounting principles, and that receipts and expenditures of the entity are being made only in accordance with authorizations of management and directors of the entity; and (3) provide reasonable assurance regarding prevention or timely detection of unauthorized acquisition, use, or disposition of the entity's assets that could have a material effect on the financial statements.

Because of its inherent limitations, internal control over financial reporting may not prevent or detect misstatements. Also, projections of any evaluation of effectiveness to future periods are subject to the risk that controls may become inadequate because of changes in conditions, or that the degree of compliance with the policies or procedures may deteriorate.

In our opinion, management's assessment that the Trust maintained effective internal control over financial reporting as of December 31, 2006, is fairly stated, in all material respects, based on the criteria established in Internal Control – Integrated Framework issued by the Committee of Sponsoring Organizations of the Treadway Commission (COSO). Also, in our opinion, the Trust maintained, in all material respects, effective internal control over financial reporting as of December 31, 2006, based on the criteria established in Internal Control – Integrated Framework issued by the Committee of Sponsoring Organizations of the Treadway Commission (COSO).

We also have conducted our audits on the consolidated financial statements in accordance with Canadian generally accepted auditing standards. With respect to the year ended December 31, 2006, we also have conducted our audit in accordance with the standards of the Public Company Accounting Oversight Board (United States). Our report dated February 13, 2007, expressed an unqualified opinion on those consolidated financial statements.

KPMG LLP

*Chartered Accountants
Calgary, Alberta*

February 13, 2007

CONSOLIDATED BALANCE SHEETS

As at
December 31,*(Stated in thousands of Canadian dollars)*

	2006	2005
ASSETS		
Current assets:		
Accounts receivable	(Note 19) \$ 354,671	\$ 500,655
Income taxes recoverable	8,701	–
Inventory	9,073	7,035
	<u>372,445</u>	<u>507,690</u>
Property, plant and equipment, net of accumulated depreciation	(Note 5) 1,107,617	943,900
Intangibles, net of accumulated amortization of \$503 (2005 – \$413)	375	465
Goodwill	280,749	266,827
	<u>\$ 1,761,186</u>	<u>\$ 1,718,882</u>
LIABILITIES AND UNITHOLDERS' EQUITY		
Current liabilities:		
Bank indebtedness	(Note 6) \$ 36,774	\$ 20,468
Accounts payable and accrued liabilities	(Note 19) 130,202	134,303
Incomes taxes payable	–	163,530
Distributions payable	(Note 7) 38,985	36,635
	<u>205,961</u>	<u>354,936</u>
Long-term incentive plan payable	22,699	–
Long-term debt	(Note 8) 140,880	96,838
Future income taxes	(Note 9) 174,571	192,517
	<u>544,111</u>	<u>644,291</u>
Commitments and contingencies	(Notes 12 and 20)	
Unitholders' equity:		
Unitholders' capital	(Note 10) 1,412,294	1,377,875
Deficit	(195,219)	(303,284)
	<u>1,217,075</u>	<u>1,074,591</u>
	<u>\$ 1,761,186</u>	<u>\$ 1,718,882</u>

See accompanying notes to consolidated financial statements.

Approved by the Board of Trustees:

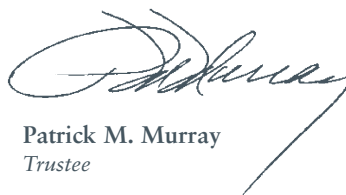
Robert J.S. Gibson
Trustee

Patrick M. Murray
Trustee

CONSOLIDATED STATEMENTS OF EARNINGS AND RETAINED EARNINGS (DEFICIT)

Years ended
December 31,

<i>(Stated in thousands of Canadian dollars, except per unit/share amounts)</i>	2006	2005	2004
Revenue	\$ 1,437,584	\$ 1,269,179	\$ 1,028,488
Expenses:			
Operating	688,207	641,805	566,297
General and administrative	81,217	76,397	64,149
Depreciation and amortization	73,234	71,561	74,829
Foreign exchange	(353)	(3,474)	(8,100)
Reorganization costs	–	17,512	–
	<u>842,305</u>	<u>803,801</u>	<u>697,175</u>
Operating earnings	595,279	465,378	331,313
Interest:			
Long-term debt	8,800	38,735	46,575
Other	171	558	246
Income	(942)	(10,023)	(541)
Premium on redemption of bonds	–	71,885	–
Loss on disposal of short-term investments	–	70,992	–
Other	(408)	–	(4,899)
Earnings from continuing operations before income taxes	587,658	293,231	289,932
Income taxes:			
Current	34,526	241,402	53,698
Future	(19,380)	(169,019)	48,103
	<u>15,146</u>	<u>72,383</u>	<u>101,801</u>
Earnings from continuing operations	572,512	220,848	188,131
Gain (loss) on disposal of discontinued operations, net of tax	7,077	1,335,382	(616)
Discontinued operations, net of tax	–	74,333	59,889
Net earnings	579,589	1,630,563	247,404
Retained earnings (deficit), beginning of year	(303,284)	1,041,683	794,279
Adjustment on cash purchase of employee stock options, net of tax of \$22,060	–	(42,087)	–
Reclassification from contributed surplus on cash buy-out of employee stock options	–	23,215	–
Distribution of disposal proceeds	–	(2,851,784)	–
Repurchase of common shares of dissenting shareholders	–	(34,364)	–
Distributions declared	(471,524)	(70,510)	–
Retained earnings (deficit), end of year	<u>\$ (195,219)</u>	<u>\$ (303,284)</u>	<u>\$ 1,041,683</u>
Earnings per unit/share from continuing operations:			
Basic	\$ 4.56	\$ 1.79	\$ 1.63
Diluted	\$ 4.56	\$ 1.76	\$ 1.61
Earnings per unit/share:			
Basic	\$ 4.62	\$ 13.22	\$ 2.14
Diluted	\$ 4.62	\$ 13.00	\$ 2.11

See accompanying notes to consolidated financial statements.

CONSOLIDATED STATEMENTS OF CASH FLOW

Years ended
December 31,

	(Stated in thousands of Canadian dollars)	2006	2005	2004
Cash provided by (used in):				
Continuing operations:				
Earnings from continuing operations		\$ 572,512	\$ 220,848	\$ 188,131
Adjustments and other items not involving cash:				
Long-term incentive plan compensation		22,699	–	–
Depreciation and amortization		73,234	71,561	74,829
Future income taxes		(19,380)	(169,019)	48,103
Stock-based compensation		–	11,229	8,190
Write-off of deferred financing costs		–	7,664	–
Loss in market value of short-term investments		–	70,992	–
Amortization of deferred financing costs		–	1,453	1,579
Unrealized foreign exchange gain on long-term monetary items		–	(4,740)	(4,284)
Other		(408)	–	(4,899)
Changes in non-cash working capital balances	(Note 19)	(38,913)	(3,975)	(25,212)
		609,744	206,013	286,437
Discontinued operations:				
Funds provided by discontinued operations	(Note 24)	–	183,330	187,018
Changes in non-cash working capital balances of discontinued operations		–	(86,310)	(26,797)
		–	97,020	160,221
Investments:				
Business acquisitions, net of cash acquired	(Notes 15 and 24)	(16,428)	(30,421)	(679,814)
Purchase of property, plant and equipment		(263,030)	(155,231)	(122,692)
Proceeds on sale of property, plant and equipment		29,337	15,174	8,795
Proceeds on disposal of discontinued operations	(Note 24)	7,337	1,306,799	49,299
Proceeds on disposal of investments		510	14,569	8,665
Purchase of property, plant and equipment of discontinued operations		–	(128,214)	(159,532)
Proceeds on sale of property, plant and equipment of discontinued operations		–	17,785	21,145
Purchase of intangibles		–	(20)	–
Purchase of intangibles of discontinued operations		–	–	(320)
Investments		–	–	(90)
Changes in non-cash working capital balances	(Note 19)	7,551	(2,912)	1,384
		(234,723)	1,037,529	(873,160)
Financing:				
Distributions paid	(Note 7)	(444,651)	(33,875)	–
Repayment of long-term debt		(204,910)	(703,970)	(173,260)
Increase in long-term debt		248,338	96,826	522,136
Issuance of Trust units		9,896	–	–
Issuance of Trust units on exercise of options		–	8,263	–
Issuance of Trust units on purchase of options		–	5,504	–
Distribution of disposal proceeds	(Note 24)	–	(844,334)	–
Cash buy-out of employee stock options		–	(64,147)	–
Repurchase of common shares of dissenting shareholders		–	(43,299)	–
Issuance of common shares on exercise of options		–	73,930	55,361
Issuance of common shares, net of costs		–	–	276,428
Deferred financing costs on long-term debt		–	–	(5,612)
Changes in non-cash working capital balances		–	22,060	–
Change in bank indebtedness		16,306	20,468	(147,909)
		(375,021)	(1,462,574)	527,144
Increase (decrease) in cash and cash equivalents		–	(122,012)	100,642
Cash and cash equivalents, beginning of year		–	122,012	21,370
Cash and cash equivalents, end of year		\$ –	\$ –	\$ 122,012

See accompanying notes to consolidated financial statements.

NOTES TO CONSOLIDATED FINANCIAL STATEMENTS

(Tabular amounts are stated in thousands of Canadian dollars except unit/share numbers and per unit/share amounts)

NOTE 1 DESCRIPTION OF BUSINESS

Precision Drilling Trust (the “Trust”) is a provider of contract drilling, service rig and ancillary services to oil and natural gas exploration and production companies in Canada and the United States.

The Trust is an unincorporated open-ended investment trust governed by the laws of Alberta and created pursuant to the Declaration of Trust dated September 22, 2005. On September 29, 2005, the Trust, Precision Drilling Limited Partnership (“PDLP”), 1194312 Alberta Ltd., 1195309 Alberta ULC., and Precision Drilling Corporation (“Precision”) entered into an Arrangement Agreement (“Plan of Arrangement” or the “Plan”) to convert Precision to an income trust. As part of the Plan of Arrangement, on November 7, 2005, Precision Drilling Corporation and certain of its subsidiaries amalgamated, and continued as one corporation (“PDC”). After giving effect to the Plan, and related transactions, all of the shares of PDC are owned by PDLP and indirectly by the Trust.

Prior to the Plan of Arrangement effective date of November 7, 2005, the consolidated financial statements included the accounts of Precision, its subsidiaries and its partnerships, substantially all of which were wholly-owned. The conversion to a trust has been accounted for on a continuity of interest basis and accordingly, the consolidated financial statements reflect the financial position, results of operations and cash flows as if the Trust had always carried on the business formerly carried on by Precision. Due to the conversion to a trust, certain information included in the financial statements for prior periods may not be directly comparable.

Pursuant to the Plan of Arrangement, shareholders ultimately received either Trust units or a combination of Trust units and exchangeable LP units of PDLP for each previously held common share of Precision (other than dissenting shareholders, who received cash equal to the fair value of their shares). After giving effect to the Plan, the consolidated financial statements include the accounts of the Trust, its subsidiaries and its partnerships.

NOTE 2 SIGNIFICANT ACCOUNTING POLICIES

(a) Basis of presentation

The Trust’s accounting policies are in accordance with Canadian generally accepted accounting principles (“GAAP”). These policies are consistent with accounting principles generally accepted in the United States in all material respects except as outlined in Note 16.

The preparation of the consolidated financial statements requires management to make estimates and assumptions that affect the reported amounts of assets, liabilities, revenues and expenses, and the disclosure of contingencies. Significant estimates used in the preparation of the financial statements include, but are not limited to, depreciation of property, plant and equipment, valuation of long-lived assets and goodwill, allowance for doubtful accounts, accrual for long-term incentive plan, and income taxes. Actual results could differ from these and other estimates, the impact of which would be recorded in future periods.

Certain of the prior period’s figures have been reclassified to conform to the current year’s presentation.

(b) Principles of consolidation

The consolidated financial statements include the accounts of the Trust and all of its subsidiaries and partnerships substantially all of which are wholly-owned. All significant intercompany balances and transactions have been eliminated.

The Trust does not hold investments in any companies where it exerts significant influence and does not hold interests in any variable interest entities.

(c) Cash and cash equivalents

Cash and cash equivalents consist of cash and short-term investments with original maturities of three months or less.

(d) Inventory

Inventory is primarily comprised of operating supplies and is carried at the lower of average cost, being the cost to acquire the inventory, and replacement cost. Inventory is charged to operating expenses as items are sold or consumed at the amount of the average cost of the item.

(e) Property, plant and equipment

Property, plant and equipment are carried at cost, including costs of direct material and labour. Where costs are incurred to extend the useful life of property, plant and equipment or to increase its capabilities, the amounts are capitalized to the related asset. Costs incurred to repair or maintain property, plant and equipment are expensed as incurred.

Property, plant, and equipment are depreciated as follows:

	Expected life	Salvage value	Basis of depreciation
Drilling rig equipment	5,000 ⁽¹⁾ utilization days	20%	unit-of-production
Drill pipe and drill collars	1,500 ⁽¹⁾ operating days	–	unit-of-production
Service rig equipment	24,000 service hours	20%	unit-of-production
Drilling rig spare equipment	15 years	–	straight-line
Rental equipment	10 to 15 years	–	straight-line
Other equipment	3 to 10 years	–	straight-line
Light duty vehicles	4 years	–	straight-line
Heavy duty vehicles	7 to 10 years	–	straight-line
Buildings	10 to 20 years	–	straight-line

(1) See note 3.

(f) Intangibles

Intangibles, which are comprised primarily of patents, are recorded at cost and amortized by the straight-line method over their useful lives ranging from 10 to 12 years. The weighted average amortization period is 12 years, and amortization over the next five years is anticipated to be \$90,000 per year for years one through four and \$9,000 for year five.

(g) Goodwill

Goodwill is the amount that results when the purchase price of an acquired business exceeds the sum of the amounts allocated to the assets acquired, less liabilities assumed, based on their fair values. Goodwill is allocated as of the date of the business combination to the Trust's reporting segments that are expected to benefit from the business combination.

Goodwill is not amortized and is tested for impairment annually in the fourth quarter, or more frequently if events or changes in circumstances indicate that the asset might be impaired. The impairment test is carried out in two steps.

In the first step, the carrying amount of the reporting segment is compared with its fair value. When the fair value of a reporting segment exceeds its carrying amount, goodwill of the reporting segment is considered not to be impaired and the second step of the impairment test is unnecessary. The second step is carried out when the carrying amount of a reporting segment exceeds its fair value, in which case the implied fair value of the reporting segment's goodwill is compared with its carrying amount to measure the amount of the impairment loss, if any. The implied fair value of goodwill is determined in the same manner as the value of goodwill is determined in a business combination, as described in the preceding paragraph, using the fair value of the reporting segment as if it was the purchase price. When the carrying amount of a reporting segment's goodwill exceeds the implied fair value of the goodwill, an impairment loss is recognized in an amount equal to the excess.

(h) Long-lived assets

On a periodic basis, management assesses the carrying value of long-lived assets for indications of impairment. Indications of impairment include an ongoing lack of profitability and significant changes in technology. When an indication of impairment is present, the Trust tests for impairment by comparing the carrying value of the asset to its net recoverable amount. If the carrying amount is greater than the net recoverable amount, the asset is written down to its estimated fair value.

(i) Income taxes

Income earned directly by PDLP is not subject to income taxes as its income is taxed directly to the PDLP partners. The Trust is a taxable entity under the Income Tax Act (Canada) and income earned is taxable only to the extent it is not distributed or distributable to its holders of Trust units and exchangeable LP units (together "Unitholders"). As the Trust distributes all of its taxable income to its respective Unitholders pursuant to the requirements of the Declaration of Trust, it does not make a provision for future income taxes.

PDC and its subsidiaries follow the liability method of accounting for future income taxes. Under the liability method, future income tax assets and liabilities are determined based on "temporary differences" (differences between the accounting basis and the tax basis of the assets and liabilities), and are measured using current or substantively enacted tax rates and laws expected to apply when these differences reverse. The effect of a change in income tax rates on future tax liabilities and assets is recognized in income in the period in which the change occurs.

During 2006 the Government of Canada released for comment draft legislation which would result in a tax structure for trusts similar to that of corporate entities. If the proposed legislation is implemented, the Trust would be required to recognize, on a prospective basis, future income taxes on temporary differences in the Trust.

(j) Revenue recognition

The Trust's services are generally sold based upon purchase orders or contracts with a customer that include fixed or determinable prices based upon daily, hourly or job rates. Customer contract terms do not include provisions for significant post-service delivery obligations. Revenue is recognized when services and equipment rentals are rendered and only when collectability is reasonably assured.

(k) Employee benefit plans

At December 31, 2006, approximately 37% (2005 – 44%) of the employees of the Trust's subsidiaries were enrolled in defined contribution retirement plans.

Employer contributions to defined contribution plans are expensed as employees earn the entitlement and contributions are made.

(l) Long-term incentive plan

In 2006, the Trust instituted a long-term incentive plan (the "LTIP") which compensates officers and key employees through cash payments at the end of a three-year term. The compensation is comprised of two components, a retention award and a performance award. The retention award is a lump sum amount determined at the date of commencement in the LTIP and is accrued and charged to earnings on a straight-line basis over the three-year term. The performance component is based on the growth in cash distributions measured against a base distribution rate as determined by the Compensation Committee of Precision. The estimated cost of the performance component is accrued over the three-year term of the plan.

(m) Foreign currency translation

Accounts of the Trust's integrated foreign operations are translated to Canadian dollars using average exchange rates for the month of the respective transaction for revenue and expenses. Monetary assets and liabilities are translated at the year-end current exchange rate and non-monetary assets and liabilities are translated using historical rates of exchange. Gains or losses resulting from these translation adjustments are included in net earnings.

Transactions in foreign currencies are translated at rates in effect at the time of the transaction. Monetary assets and liabilities are translated at current rates. Gains and losses are included in net earnings.

(n) Stock-based compensation plans

The Trust had equity incentive plans in 2005 and prior periods, which are described in Note 23(c). The fair value of common share purchase options was calculated at the date of grant using the Black-Scholes option pricing model and that value was recorded as compensation expense on a straight-line basis over the grant's vesting period with an offsetting credit to contributed surplus. Upon exercise of the equity purchase option, the associated amount was reclassified from contributed surplus to Unitholders' capital as appropriate. Consideration paid by employees upon exercise of equity purchase options was credited to Unitholders' capital as appropriate.

(o) Exchangeable LP units

Exchangeable LP units are presented as equity of the Trust as their features make them economically equivalent to Trust units.

(p) Per unit amounts

Basic per unit amounts are calculated using the weighted average number of Trust units outstanding during the year. Diluted per unit amounts are calculated based on the treasury stock method, which assumes that any proceeds obtained on exercise of options would be used to purchase Trust units at the average market price during the period. The weighted average number of units outstanding is then adjusted by the difference between the number of units issued from the exercise of options and units repurchased from the related proceeds.

The Trust had no dilutive instruments outstanding during the year ended December 31, 2006.

NOTE 3 ACCOUNTING ESTIMATES

Effective January 1, 2005, the Trust changed the useful life of its drilling rigs for purposes of determining depreciation expense to 5,000 utilization days from 4,150 utilization days (3,650 operating days), and its drill string to 1,500 from 1,100 operating days. Utilization days include both operating and rig move days. This change in accounting estimate was applied prospectively and resulted in a \$10.7 million reduction in depreciation expense, or \$0.09 per diluted unit/share, for the year ended December 31, 2005.

NOTE 4 ACCOUNTING CHANGES*Stock-based compensation plans*

Effective January 1, 2004, the Trust adopted the revised Canadian accounting standards with respect to accounting for stock-based compensation. Under those standards, the fair value of common share purchase options is calculated at the date of the grant and that value is recorded as compensation expense over the vesting period of those grants. Under the previous standard, no compensation expense was recorded when stock options were issued with any consideration received upon exercise credited to share capital.

The Trust has retroactively applied this standard, with restatement of prior years, to all common share purchase options granted since January 1, 2002. This has resulted in a charge to net earnings for the year ended December 31, 2004 of \$13.8 million or \$0.11 diluted earnings per share and a reduction to opening retained earnings of \$14.5 million at January 1, 2004.

NOTE 5 PROPERTY, PLANT AND EQUIPMENT

2006	Cost	Accumulated Depreciation	Net Book Value
Rig equipment	\$ 1,294,289	\$ 434,491	\$ 859,798
Rental equipment	94,184	40,658	53,526
Other equipment	95,137	61,317	33,820
Vehicles	78,675	24,461	54,214
Buildings	29,583	9,673	19,910
Assets under construction	76,239	–	76,239
Land	10,110	–	10,110
	<u>\$ 1,678,217</u>	<u>\$ 570,600</u>	<u>\$ 1,107,617</u>
2005	Cost	Accumulated Depreciation	Net Book Value
Rig equipment	\$ 1,143,786	\$ 386,191	\$ 757,595
Rental equipment	81,099	35,307	45,792
Other equipment	102,727	62,852	39,875
Vehicles	68,911	20,703	48,208
Buildings	32,830	9,580	23,250
Assets under construction	20,184	–	20,184
Land	8,996	–	8,996
	<u>\$ 1,458,533</u>	<u>\$ 514,633</u>	<u>\$ 943,900</u>

NOTE 6 BANK INDEBTEDNESS

At December 31, 2006 and 2005, the Trust had available \$60.0 million and US\$5.0 million under uncommitted, unsecured credit facilities, of which \$36.8 million had been drawn (2005 – \$20.5 million). Availability of these facilities were reduced by outstanding letters of credit in the amount of \$4.0 million (2005 – \$8.4 million). Advances under the facilities are available at the bank's prime lending rate, U.S. base rate, U.S. Libor plus applicable margin or Banker's Acceptance plus applicable margin, or in combination. As at December 31, 2006, the amounts drawn under these facilities were at the bank's prime lending rate of 6% (2005 – 5%).

NOTE 7

DISTRIBUTIONS

The beneficiaries of the Trust are the holders of Trust units and the partners of PDLP are the holders of exchangeable LP units and the Trust. The monthly distributions made by the Trust to Unitholders are determined by the Trustees. PDLP earns interest income from a promissory note issued by its subsidiary PDC at a rate which is determined by the terms of the promissory note. PDLP in substance pays distributions to holders of exchangeable LP units in amounts equal to the distributions paid to the holders of Trust units. All distributions are made to Unitholders of record on the last business day of each calendar month.

The Declaration of Trust provides that an amount equal to net income of the Trust not already paid to Unitholders in the year will become payable on December 31 of each year such that the Trust will not be liable for ordinary income taxes for such year.

A distribution reinvestment plan (the “DRIP”) was approved by the Board of Trustees in February 2006, and implemented in March 2006. The DRIP allows certain holders of Trust units, at their option, to reinvest monthly cash distributions to acquire additional Trust units at the average market price as defined in the DRIP. Unitholders who are not resident in Canada or hold exchangeable LP units are not eligible to participate in the DRIP. The Trust reserved the right to amend, suspend, or terminate the DRIP at any time. The DRIP was suspended in December 2006.

A summary of the distributions is as follows:

	2006	2005
Declared	\$ 471,524	\$ 70,510
Paid	\$ 444,651	\$ 33,875
Payable in cash at December 31	\$ 38,985	\$ 36,635
Payable in units at December 31	\$ 24,523	\$ –

Included in the 2006 distributions declared is a special non-cash distribution of \$24.5 million (\$0.195 per unit). This special distribution was settled on January 16, 2007 through the issuance of units. Immediately following the issuance of these units, the Trust consolidated the units such that the number of Trust units and exchangeable LP units remained unchanged from the number outstanding prior to the special distribution.

NOTE 8

LONG-TERM DEBT*Extendible revolving unsecured facility:*

At December 31, 2006, PDC, a subsidiary of the Trust, has available a three-year revolving unsecured facility of \$700.0 million (or U.S. equivalent) (2005 – \$550.0 million) with a syndicate led by a Canadian chartered bank, which is guaranteed by the Trust. The facility matures on November 2, 2009 and is renewable annually at the option of the lenders. Advances are available to PDC under this facility either at the bank’s prime lending rate, U.S. base rate, U.S. Libor plus applicable margin or Bankers’ Acceptance plus applicable margin or in combination. The applicable margin is dependent on the Trust’s consolidated debt to cash flow ratio and the percentage of the total facility outstanding, which at December 31, 2006 and 2005 was 75 basis points. The facility requires that the Trust maintain a ratio of total liabilities to total equity of less than 1:1, a trailing 12 month ratio of consolidated debt to cash flow of less than 2.75:1 and total distributions to Unitholders of less than 100% of consolidated cash flow as defined in the facility agreement. As at December 31, 2006, the Trust had drawn \$140.9 million (2005 – \$96.8 million) under this facility.

Unsecured debentures and notes:

During the fourth quarter of 2005, Precision repaid all of its outstanding debentures and notes pursuant to the early redemption provisions of the related agreements. The difference between the \$766.7 million redemption price and the carrying value of the debentures was charged to income.

INCOME TAXES

The provision for income taxes differs from that which would be expected by applying Canadian statutory income tax rates as follows:

	2006	2005	2004
Earnings from continuing operations before income taxes	\$ 587,658	\$ 293,231	\$ 289,932
Federal and provincial statutory rates	33%	34%	36%
Tax at statutory rates	\$ 193,927	\$ 99,699	\$ 104,375
Adjusted for the effect of:			
Non-deductible expenses	297	2,795	4,965
Non-deductible stock-based compensation	-	3,216	2,948
Income to be distributed to Unitholders, not subject to tax in the Trust	(155,354)	(23,980)	-
Utilization of losses and surcharge credits	-	(10,550)	-
Other	(2,896)	1,203	(7,600)
Income tax expense before tax rate reductions	35,974	72,383	104,688
Reduction of future income tax balances due to enacted tax rate reductions	(20,828)	-	(2,887)
Income tax expense	\$ 15,146	\$ 72,383	\$ 101,801
Effective income tax rate before enacted tax rate reductions	6%	25%	36%

In 2006 the federal and certain provincial governments enacted various reductions to corporate income tax rates. The Government of Canada introduced tax rate reductions to be implemented over the next four years that will decrease the federal corporate income tax rate from 21% to 19%. The federal corporate capital tax was eliminated effective January 1, 2006 and the federal corporate surtax will be eliminated in 2008. The Province of Alberta reduced the corporate income tax rate by 1.5% (2004 – 1.0%) effective April 1, 2006. These and other provincial corporate income tax rate reductions have been reflected as a reduction of future tax expense.

The net future tax liability is comprised of the tax effect of the following temporary differences:

	2006	2005
Future income tax liability:		
Property, plant and equipment and intangibles	\$ 213,281	\$ 232,277
Future income tax assets:		
Bond redemption premium	13,314	20,820
Losses carried forward	9,884	14,586
Share issue costs	1,966	3,039
Long-term incentive plan	10,614	-
Accrued liabilities	2,937	1,910
Valuation allowance	(5)	(595)
	38,710	39,760
Net future income tax liability	\$ 174,571	\$ 192,517

PDC and its subsidiaries have available net capital losses of \$33.6 million of which, after valuation allowances, the benefit of \$33.6 million has been recognized. These capital losses can be carried forward indefinitely.

During 2004, \$7.5 million representing future tax expense on foreign exchange gains associated with the Trust's U.S.\$300 million unsecured notes was charged to the cumulative translation account in Unitholders' equity. This amount was related to the Trust's discontinued operations.

UNITHOLDERS' CAPITAL

- (a) *Authorized* – unlimited number of voting Trust units
 – unlimited number of voting exchangeable LP units

(b) *Unitholders' capital*

Trust units	Number	Amount
Balance, November 7, 2005	–	\$ –
Issued pursuant to the Plan	122,512,799	1,339,646
Options exercised – cash consideration	1,676,616	8,263
– reclassification from contributed surplus	–	12,342
Issued for cash	163,506	5,504
Balance, December 31, 2005	124,352,921	1,365,755
Issued pursuant to distribution reinvestment plan (Note 7)	296,621	9,896
Issued on retraction of exchangeable LP units	886,787	9,697
Issued and consolidated pursuant to special distribution (Note 7)	–	24,480
Balance, December 31, 2006	125,536,329	\$ 1,409,828

Trust units are redeemable at the option of the holder, at which time all rights with respect to such units are cancelled. Upon redemption, the unitholder is entitled to receive a price per unit equal to the lesser of 90% of the average market price of the Trust's units for the 10 trading days just prior to the date of redemption, and the closing market price of the Trust's units on the date of redemption. The maximum value of units that can be redeemed for cash is \$50,000 per month. Redemptions, if any, in excess of this amount are satisfied by issuing a note from PDC to the unitholder, payable over 15 years and bearing interest at a market rate set by the Board of Directors.

Exchangeable LP units	Number	Amount
Balance, November 7, 2005	–	\$ –
Issued pursuant to the Plan	1,108,382	12,120
Balance, December 31, 2005	1,108,382	12,120
Redeemed on retraction of exchangeable LP units	(886,787)	(9,697)
Issued and consolidated pursuant to special distribution (Note 7)	–	43
Balance, December 31, 2006	221,595	\$ 2,466

Exchangeable LP units have voting rights and were exchangeable, after May 6, 2006, for Trust units on a one-for-one basis at the option of the holder. Holders are entitled to monthly cash distributions equal to those paid to holders of Trust units.

Summary as at December 31,	2006		2005	
	Number	Amount	Number	Amount
Trust units	125,536,329	\$ 1,409,828	124,352,921	\$ 1,365,755
Exchangeable LP units	221,595	2,466	1,108,382	12,120
Unitholders' capital	125,757,924	\$ 1,412,294	125,461,303	\$ 1,377,875

EMPLOYEE BENEFIT PLANS

The Trust has registered pension plans covering a significant number of its employees.

(a) *Defined contribution plan*

Under the defined contribution plan, the Trust matches individual contributions up to 5% of the employee's compensation. Total expense under the defined contribution plan in 2006 was \$5.5 million (2005 – \$8.5 million; 2004 – \$7.3 million), of which \$nil (2005 – \$3.2 million; 2004 – \$3.0 million) relates to discontinued operations.

(b) *Retirement allowance*

The Trust had entered into an employment agreement with a senior officer, which provided for a one-time payment upon retirement. The amount of this retirement allowance increased by a fixed amount for each year of service over a ten year period commencing April 30, 1996. The estimated cost of this benefit was being accrued and charged to earnings on a straight-line basis over the ten year period. During the year ended December 31, 2005, the Trust charged \$201,000 (2004 – \$335,000) and paid \$2.9 million as final settlement of this liability.

NOTE 12

COMMITMENTS

The Trust has commitments for operating lease agreements, primarily for vehicles and office space, in the aggregate amount of \$26.5 million. Payments over the next five years are as follows:

	Total
2007	\$ 7,858
2008	6,551
2009	4,820
2010	4,044
2011	<u>3,265</u>

Rent expense included in the statements of earnings is as follows:

	Continuing Operations	Discontinued Operations	Total
2006	\$ 4,189	\$ –	\$ 4,189
2005	3,836	11,983	15,819
2004	<u>5,874</u>	<u>17,284</u>	<u>23,158</u>

NOTE 13

PER UNIT/SHARE AMOUNTS

The following table summarizes the units, adjusted retroactively for a 2 for 1 stock split on May 18, 2005, used in calculating earnings per unit/share:

<i>(Stated in thousands)</i>	2006	2005	2004
Weighted average units/shares outstanding – basic	<u>125,545</u>	<u>123,304</u>	<u>115,654</u>
Effect of stock options	–	2,108	1,556
Weighted average units/shares outstanding – diluted	<u>125,545</u>	<u>125,412</u>	<u>117,210</u>

NOTE 14

SIGNIFICANT CUSTOMERS

During the year ended December 31, 2006 no customers (2005 – no customers; 2004 – one customer) accounted for more than 10% of the Trust's revenue.

NOTE 15

BUSINESS ACQUISITIONS

Acquisitions have been accounted for by the purchase method with results of operations acquired included in the consolidated financial statements from the closing date of acquisition. Acquisitions relating to discontinued operations are reflected in Note 24.

On August 17, 2006, the Trust acquired all of the shares of Terra Water Group Ltd. ("Terra"), a privately owned provider of wastewater treatment units for the traditional drilling rig camp market in western Canada. The Terra operations are included in the Completion and Production Services segment. The acquisition has been accounted for by the purchase method with the results of operations included in the financial statements from the date of acquisition. The details of the acquisition are as follows:

Net assets acquired at assigned values:

Working capital ⁽¹⁾	\$ 207
Property, plant and equipment	3,168
Goodwill (no tax basis)	13,922
Long-term debt	(614)
Future income taxes	<u>(212)</u>
	<u>\$ 16,471</u>
Consideration:	
Cash	<u>\$ 16,471</u>

(1) Working capital includes cash of \$43

UNITED STATES GENERALLY ACCEPTED ACCOUNTING PRINCIPLES

These financial statements have been prepared in accordance with Canadian GAAP which conform with United States generally accepted accounting principles (U.S. GAAP) in all material respects, except as follows:

(a) Income taxes

In 2000 the Trust adopted the liability method of accounting for future income taxes without restatement of prior years. As a result, the Trust recorded an adjustment to retained earnings and future tax liability in the amount of \$70.0 million at January 1, 2000. U.S. GAAP required the use of the liability method prescribed in the Statement of Financial Accounting Standards (SFAS) No. 109, which substantially conforms to the Canadian GAAP accounting standard adopted in 2000. Application of U.S. GAAP in years prior to 2000 would have resulted in \$70.0 million of additional goodwill being recognized at January 1, 2000 as opposed to an implementation adjustment to retained earnings allowed under Canadian GAAP. Prior to 2002 goodwill was amortized under Canadian and U.S. GAAP. As a result, \$7.0 million of amortization was recorded on the additional goodwill in 2000 and 2001 under U.S. GAAP. In 2005 and 2006 the U.S. GAAP financial statements would reflect an increase in goodwill of \$63.0 million and a corresponding increase in retained earnings.

(b) Stock-based compensation

In 2004, under Canadian GAAP, the Trust adopted the fair value of accounting for stock-based compensation with restatement of prior years for share purchase options granted after January 1, 2002. U.S. GAAP allows the use of either the intrinsic method, as prescribed by Accounting Principles Board (APB) Opinion 25, or the fair value method as prescribed by SFAS 123. Where companies elect to use the intrinsic method, disclosure of the impact of using the fair value method is required.

Application of the intrinsic method in accordance with APB Opinion 25 would have resulted in an increase in net earnings of \$21.3 million for 2005 (2004 – \$13.8 million) with a corresponding increase in Unitholders' equity. Had the Trust determined compensation based on the fair value at the date of grant for its options under SFAS 123, net earnings in accordance with U.S. GAAP would have decreased to \$1,588.5 million in 2005 (2004 – decreased to \$247.8 million). Basic earnings per unit/share would have been \$12.88 in 2005 (2004 – \$2.14).

Under Financial Accounting Standards Board ("FASB") Interpretation No. 44 ("FIN 44") *Accounting for Certain Transactions Involving Stock Compensation*, compensation expense is required to be recognized on certain modifications to stock-based compensation plans. During the year ended December 31, 2005, employee stock options ("options") were subjected to a variety of changes or restructurings which included accelerated vesting, repricing on the date of conversion to an income trust to reflect the distribution of disposal consideration to Precision's shareholders just prior to conversion, or repurchase for cash depending on elections made by the option holders. Under Canadian GAAP, even with repricing, the options were treated as equity awards and were not accounted for under a variable accounting method. However, under U.S. GAAP, the accelerated vesting represents a restructuring in the form of a modification that would result in a new measurement of compensation expense on the date of the modification to the date of exercise using the intrinsic method. For award repricing, this restructuring only results in additional expense provided that the aggregate intrinsic value of the awards immediately after the change is not greater than that immediately before, and the ratio of exercise price per unit/share to the market value per unit/share is not reduced. To the extent that both criteria are not met, the awards are accounted for under ABP Opinion 25 as a variable award from the date of restructuring to the date the award was exercised. For restructuring in the form of cash buy-out of the options, the intrinsic value was charged to retained earnings under Canadian GAAP, however, under U.S. GAAP the amount was charged to earnings.

(c) Redemption of Trust units

Under the Declaration of Trust, Trust units are redeemable at any time on demand by the unitholder for cash and notes (see Note 10). Under U.S. GAAP, the amount included on the consolidated balance sheet for Unitholders' equity would be moved to temporary equity and recorded at an amount equal to the redemption value of the Trust units as at the balance sheet date. The same accounting treatment would be applicable to the exchangeable LP units. The redemption value of the Trust units and the exchangeable LP units is determined with respect to the trading value of the Trust units as at each balance sheet date, and the amount of the redemption value is classified as temporary equity. Changes (increases and decreases) in the redemption value during a period results in a change to temporary equity and is charged to retained earnings.

(d) Acquisitions

Under U.S. GAAP, when significant acquisitions have occurred, supplemental disclosure is required on a pro forma basis of the results of operations for the current prior periods as though the business combination had occurred at the beginning of the period unless it is not practicable to do so. At December 31, 2005, the Trust did not have access to sufficient information to provide this disclosure for acquisitions completed in 2004. No significant acquisitions occurred in 2006.

(e) Recently issued accounting pronouncements

On September 15, 2006, FASB issued SFAS 157, *Fair Value Measurements*. The statement provides enhanced guidance for using fair value to measure assets and liabilities, but does not expand the use of fair value in any new circumstances. The new standard is effective for fiscal years beginning after November 15, 2007, and will be effective for the Trust's December 31, 2008 year end. Management does not expect this statement to have a material impact on the consolidated financial statements.

In June 2006, FASB issued Interpretation No. 48, *Accounting for Uncertainty in Income Taxes – an interpretation of FASB Statement No. 109*. The interpretation clarifies the accounting for uncertainty in income taxes by prescribing a consistent recognition threshold and measurement attribute for the financial statement recognition and measurement of a tax position taken or expected to be taken on a tax return. The interpretation is effective for fiscal years beginning after December 15, 2006, and will be effective for the Trust's December 31, 2007 year end. The impact of this interpretation is yet to be determined by management.

On February 16, 2006, FASB issued SFAS 155, *Accounting for Certain Hybrid Financial Instruments – an amendment of FASB Statements no. 133 and 140*. The statement clarifies and simplifies the financial reporting of certain hybrid financial instruments by requiring more consistent accounting that eliminates exemptions. The new standard is effective for financial instruments acquired or issued after the beginning of an entity's first fiscal year that begins after September 15, 2006, and will be effective for the Trust's first quarter of the December 31, 2007 year end. Management does not expect this statement to have a material impact on the consolidated financial statements.

The application of U.S. GAAP accounting principles would have the following impact on the consolidated financial statements:

Consolidated Statements of Earnings

Years ended December 31,	2006	2005	2004
Earnings from continuing operations under Canadian GAAP	\$ 572,512	\$ 220,848	\$ 188,131
Adjustments under U.S. GAAP:			
Stock-based compensation expense	–	11,229	8,190
Cash buy-out of options	–	(22,119)	–
Intrinsic value recognized on options exercised and/or repriced	–	(2,270)	–
Earnings from continuing operations under U.S. GAAP	572,512	207,688	196,321
Earnings from discontinued operations under Canadian GAAP	7,077	1,409,715	59,273
Adjustments under U.S. GAAP:			
Stock-based compensation expense	–	10,109	5,647
Cash buy-out of options	–	(19,968)	–
Intrinsic value recognized on options exercised and/or repriced	–	(11,796)	–
Earnings from discontinued operations under U.S. GAAP	7,077	1,388,060	64,920
Net earnings under U.S. GAAP	579,589	1,595,748	261,241
Cumulative translation adjustment	–	–	(20,933)
Comprehensive income under U.S. GAAP	\$ 579,589	\$ 1,595,748	\$ 240,308
Earnings from continuing operations per unit/share under U.S. GAAP:			
Basic	\$ 4.56	\$ 1.68	\$ 1.70
Diluted	\$ 4.56	\$ 1.66	\$ 1.67
Earnings per unit/share under U.S. GAAP:			
Basic	\$ 4.62	\$ 12.94	\$ 2.26
Diluted	\$ 4.62	\$ 12.72	\$ 2.23

Consolidated Statements of Retained Earnings (Deficit)

Years ended December 31,	2006	2005	2004
Retained earnings (deficit) under U.S. GAAP, beginning of year	\$ (3,167,045)	\$ 1,133,030	\$ 871,789
Net earnings under U.S. GAAP	579,589	1,595,748	261,241
Distributions declared	(471,524)	(70,510)	–
Distribution of disposal proceeds	–	(2,851,784)	–
Repurchase of common shares of dissenting shareholders	–	(34,364)	–
Opening temporary equity on conversion to an income trust	–	(2,560,709)	–
Change in redemption value of temporary equity	1,185,490	(378,456)	–
Retained earnings (deficit) under U.S. GAAP, end of year	<u>\$ (1,873,490)</u>	<u>\$ (3,167,045)</u>	<u>\$ 1,133,0030</u>

Consolidated Balance Sheets

As at December 31,	2006		2005	
	As reported	U.S. GAAP	As reported	U.S. GAAP
Current assets	\$ 372,445	\$ 372,445	\$ 507,690	\$ 507,690
Property, plant and equipment	1,107,617	1,107,617	943,900	943,900
Intangibles	375	375	465	465
Goodwill	280,749	343,778	266,827	329,856
	<u>\$ 1,761,186</u>	<u>\$ 1,824,215</u>	<u>\$ 1,718,882</u>	<u>\$ 1,781,911</u>
Current liabilities	\$ 205,961	\$ 205,961	\$ 354,936	\$ 354,936
Long-term incentive plan payable	22,699	22,699	–	–
Long-term debt	140,880	140,880	96,838	96,838
Future income taxes	174,571	174,571	192,517	192,517
Temporary equity	–	3,153,594	–	4,304,665
Unitholders' capital	1,412,294	–	1,377,875	–
Deficit	(195,219)	(1,873,490)	(303,284)	(3,167,045)
	<u>\$ 1,761,186</u>	<u>\$ 1,824,215</u>	<u>\$ 1,718,882</u>	<u>\$ 1,781,911</u>

NOTE 17

SEGMENTED INFORMATION

The Trust operates primarily in Canada, in two industry segments; Contract Drilling Services and Completion and Production Services. Contract Drilling Services includes drilling rigs, procurement and distribution of oilfield supplies, camp and catering services, and manufacture, sale and repair of drilling equipment. Completion and Production Services includes service rigs, snubbing units, wastewater treatment units, and oilfield equipment rental.

2006	Contract Drilling Services	Completion and Production Services	Corporate and Other	Inter-segment Eliminations	Total
Revenue	\$ 1,009,821	\$ 441,017	\$ –	\$ (13,254)	\$ 1,437,584
Operating earnings	473,624	163,119	(41,464)	–	595,279
Depreciation and amortization	38,573	32,013	2,648	–	73,234
Total assets	1,198,284	507,510	55,392	–	1,761,186
Goodwill	172,440	108,309	–	–	280,749
Capital expenditures*	220,397	39,273	3,360	–	263,030
2005	Contract Drilling Services	Completion and Production Services	Corporate and Other	Inter-segment Eliminations	Total
Revenue	\$ 916,221	\$ 369,667	\$ –	\$ (16,709)	\$ 1,269,179
Operating earnings	404,385	121,643	(60,650)	–	465,378
Depreciation and amortization	39,233	27,402	4,926	–	71,561
Total assets	1,159,687	486,701	72,494	–	1,718,882
Goodwill	172,440	94,387	–	–	266,827
Capital expenditures*	106,986	34,576	13,689	–	155,251

* Excludes business acquisitions

2004	Contract Drilling Services	Completion and Production Services	Corporate and Other	Inter-segment Eliminations	Total
Revenue	\$ 727,710	\$ 313,386	\$ –	\$ (12,608)	\$ 1,028,488
Operating earnings	282,315	77,074	(28,076)	–	331,313
Depreciation and amortization	42,245	27,508	5,076	–	74,829
Total assets	971,863	461,191	180,009	–	1,613,063
Goodwill	172,440	94,387	–	–	266,827
Capital expenditures*	74,975	31,759	15,958	–	122,692

* Excludes business acquisitions

NOTE 18

FINANCIAL INSTRUMENTS

(a) Fair value

The carrying value of cash and cash equivalents, accounts receivable, income taxes recoverable, bank indebtedness, accounts payable and accrued liabilities, income tax payable and distributions payable approximate their fair value due to the relatively short period to maturity of the instruments.

(b) Credit risk

Accounts receivable includes balances from a large number of customers primarily operating in the oil and gas industry. The Trust assesses the creditworthiness of its customers on an ongoing basis as well as monitoring the amount and age of balances outstanding. Accordingly, the Trust views the credit risks on these amounts as normal for the industry. As at December 31, 2006 the Trust's allowance for doubtful accounts was \$5.6 million (2005 – \$5.1 million).

(c) Interest rate risk

The Trust is exposed to interest rate risk with respect to interest expense on its credit facilities.

(d) Foreign currency risk

The Trust was exposed to foreign currency fluctuations in relation to its international operations prior to their disposal in 2005 (see Note 24). To manage a portion of this exposure, the Trust designated US\$300.0 million notes as a hedge against foreign currency fluctuations of its investment in self-sustaining foreign operations. A net foreign exchange gain of \$10.1 million associated with these notes was included in the cumulative translation account during 2005 (2004 – gain of \$43.1 million). The cumulative translation account at August 31, 2005 of \$24.8 million was charged to the gain on disposal of discontinued operations in 2005.

NOTE 19

SUPPLEMENTAL INFORMATION

	2006	2005	2004
Interest paid:			
– continuing operations	\$ 8,929	\$ 43,232	\$ 45,338
– discontinued operations	–	304	997
	\$ 8,929	\$ 43,536	\$ 46,335
Income taxes paid:			
– continuing operations	\$ 207,160	\$ 91,496	\$ 38,759
– discontinued operations	–	35,176	35,935
	\$ 207,160	\$ 126,672	\$ 74,694
Components of change in non-cash working capital balances:			
Accounts receivable	\$ 148,046	\$ (171,363)	\$ (42,714)
Inventory	(2,038)	699	(2,017)
Accounts payable and accrued liabilities	(4,736)	13,871	5,964
Income taxes	(172,634)	149,906	14,939
	\$ (31,362)	\$ (6,887)	\$ (23,828)

The components of accounts receivable are as follows:

	2006	2005
Trade	\$ 220,623	\$ 306,264
Accrued trade	93,308	148,537
Prepays and other	40,740	45,854
	<u>\$ 354,671</u>	<u>\$ 500,655</u>

The components of accounts payable and accrued liabilities are as follows:

	2006	2005
Accounts payable	\$ 60,650	\$ 71,027
Accrued liabilities:		
Payroll	47,001	30,351
Other	22,551	32,925
	<u>\$ 130,202</u>	<u>\$ 134,303</u>

NOTE 20

CONTINGENCIES

The business and operations of the Trust are complex and the Trust has executed a number of significant financings, business combinations, acquisitions and dispositions over the course of its history. The computation of income taxes payable as a result of these transactions involves many complex factors as well as the Trust's interpretation of relevant tax legislation and regulations. The Trust's management believes that the provision for income tax is adequate and in accordance with generally accepted accounting principles and applicable legislation and regulations. However, there are a number of tax filing positions that can still be the subject of review by taxation authorities who may successfully challenge the Trust's interpretation of the applicable tax legislation and regulations, with the result that additional taxes could be payable by the Trust and the amount payable could be up to \$300 million.

The Trust, through the performance of its services, product sales and business arrangements, is sometimes named as a defendant in litigation. The outcome of such claims against the Trust is not determinable at this time, however, their ultimate resolution is not expected to have a material adverse effect on the Trust.

The Trust maintains a level of insurance coverage deemed appropriate by management for matters for which insurance coverage can be acquired.

NOTE 21

GUARANTEES

The Trust has entered into agreements indemnifying certain parties primarily with respect to tax and specific third party claims associated with businesses sold by the Trust. Due to the nature of the indemnifications, the maximum exposure under these agreements cannot be estimated. No amounts have been recorded for the indemnities as the Trust's obligations under them are not probable or estimable.

NOTE 22

RELATED PARTY TRANSACTIONS

During the year ended December 31, 2005, the Trust incurred a total of \$6.1 million in legal fees with a law firm for various legal matters where a director of Precision Drilling Corporation was a partner. These transactions were incurred in the normal course of business and were recorded at the exchange amounts.

REORGANIZATION INTO A TRUST

To effect the reorganization into a trust, for the year ended December 31, 2005, the Trust incurred \$17.5 million of reorganization costs comprised as follows:

Severance	\$ 12,600
Legal, accounting, financial advisory services and other	4,912
	<u>\$ 17,512</u>

Share capital of Precision prior to reorganization into the Trust included:

(a) Common shares

On November 7, 2005, Precision converted to an unincorporated, open-ended investment trust pursuant to the Plan, which resulted in shareholders receiving one Trust unit or one exchangeable LP unit or a combination thereof, for each previously held common share. Common shares held by shareholders who dissented to the Plan were repurchased and cancelled on the effective date of the Plan. All outstanding common share purchase options were converted to options to acquire Trust units. The holder then had three options; exercise the options, have the Trust repurchase them for cash using the closing market price of the Trust one day prior to cash-out, or have the Trust repurchase the options as set-out above and use the proceeds to purchase an equivalent number of Trust units.

	Number	Amount
Balance, December 31, 2003	54,845,678	\$ 936,744
Issuance of common shares, net of costs and related tax effect	4,400,000	280,783
Options exercised – cash consideration	1,544,534	55,361
– reclassification from contributed surplus	–	2,079
Balance, December 31, 2004	60,790,212	1,274,967
Options exercised – cash consideration	578,346	24,516
– reclassification from contributed surplus	–	1,521
Balance, May 18, 2005	61,368,558	1,301,004
Issued on 2:1 stock split	61,368,558	–
Options exercised – cash consideration	1,679,110	49,414
– reclassification from contributed surplus	–	10,284
Adjustment to number of shares outstanding	21,960	–
Cancellation of shares owned by dissenting shareholders	(817,005)	(8,936)
Balance, November 7, 2005, before conversion to units	123,621,181	1,351,766
Conversion to Trust units	(122,512,799)	(1,339,646)
Conversion to exchangeable LP units	(1,108,382)	(12,120)
Balance, November 7, 2005, after conversion to units	–	\$ –

Pursuant to the Plan, any shareholders of Precision could dissent and be paid the fair value of the shares, being the trading price at the close of business on the last business day prior to the Special Meeting of Securityholders on October 31, 2005. As a result, the Trust repurchased for cancellation a total of 817,005 shares for \$43.3 million, of which a premium of \$34.4 million over the stated capital was charged to retained earnings.

In the third quarter of 2004, the Trust issued 4,400,000 common shares at US \$49.80 for net proceeds of approximately \$276.5 million.

(b) Contributed surplus:

Balance, December 31, 2003	\$	14,266
Stock-based compensation expense		13,837
Reclassification to common shares on exercise of options		(2,079)
Balance, December 31, 2004		26,024
Stock-based compensation expense		13,077
Accelerated vesting of options on disposal of discontinued operations		5,205
Reclassification to common shares on exercise of options prior to the Plan		(11,805)
Accelerated vesting of options pursuant to the Plan		3,056
Reclassification to Trust units on exercise of options		(12,342)
Reclassification to retained earnings on cash buy-out of options		(23,215)
Balance, December 31, 2005	\$	–

(c) Equity incentive plans

Prior to conversion to a Trust, Precision had equity incentive plans under which the exercise price of each option equaled the market value of the Corporation's stock on the date of grant and an option's maximum term was 10 years. Options vested over a period of 1 to 4 years from the date of grant as employees or directors rendered continuous service to Precision.

Options held by employees of the Energy Services and International Contract Drilling Divisions and of CEDA International Corporation ("CEDA") became fully vested when these businesses were sold during the third quarter of 2005 (see Note 24). Pursuant to the Plan, the remaining outstanding options were exchanged for newly vested options to acquire Trust units. The exercise prices of the options to acquire Trust units were adjusted downward to reflect the value of the distribution of certain assets to shareholders as part of the Plan. The options to acquire Trust units expired on November 22, 2005.

Upon acceleration of the vesting of options, options holders were given the choice to pay the exercise price and receive a common share or Trust unit, as applicable, or to surrender their option for a cash payment equal to the difference between the closing market value of the common share or Trust unit one day prior to cash buy-out and the exercise price. All outstanding options were exercised prior to December 31, 2005.

A summary of the equity incentive plans, adjusted retroactively to reflect the 2 for 1 stock split on May 18, 2005, as at December 31, 2004 and 2005 and changes during the periods then ended is presented below:

Common Share Purchase Options	Options Outstanding	Range of Exercise Price	Weighted Average Exercise Price	Options Exercisable
Outstanding at December 31, 2003	6,786,388	\$ 6.75 – 32.95	\$ 20.85	4,076,396
Granted	3,381,000	20.13 – 36.32	31.77	
Exercised	(3,089,068)	6.75 – 28.78	17.92	
Cancelled	(383,200)	15.53 – 32.95	25.68	
Outstanding at December 31, 2004	6,695,120	15.53 – 36.32	27.44	2,580,302
Granted	696,200	37.76 – 48.29	41.42	
Exercised	(2,835,802)	15.53 – 48.29	26.07	
Cancelled	(141,650)	15.53 – 31.87	30.26	
Purchased	(1,105,018)	15.53 – 45.25	31.30	
Exchanged for Trust unit purchase options	(3,308,850)	15.53 – 48.29	30.14	
Outstanding at December 31, 2005	–	\$ –	\$ –	–

Trust Unit Purchase Options	Options Outstanding	Range of Exercise Price	Weighted Average Exercise Price	Options Exercisable
Outstanding at November 7, 2005	–	\$ –	\$ –	–
Granted in exchange for common share purchase options pursuant to the Plan	3,308,850	nil – 27.25	9.16	3,308,850
Granted on repricing of common share options	5,600	nil	nil	
Exercised	(1,676,616)	nil – 27.25	4.93	
Purchased	(1,637,834)	nil – 27.25	13.46	
Outstanding at December 31, 2005	–	\$ –	\$ –	–

In accordance with the Trust's stock option plans, options had an initial exercise price equal to the market price at date of grant. The per share weighted average fair value of stock options granted during the year ended December 31, 2005 was \$8.30 (2004 – \$7.83) based on the date of grant valuation using the Black-Scholes option pricing model with the following assumptions: average risk-free interest rate of 3.28% (2004 – 3.44%), average expected life of 2.92 years (2004 – 2.97 years) and expected volatility of 28.04% (2004 – 32.33%).

For the year ended December 31, 2005 stock-based compensation costs included in net earnings totaled \$21.3 million (2004 – \$13.8 million), of which \$10.1 million (2004 – \$5.6 million) related to discontinued operations.

NOTE 24

DISCONTINUED OPERATIONS

A summary of discontinued operations is presented below including: disposal transactions; financial information with respect to amounts included in the statements of earnings and statements of cash flows; significant accounting policies relating specifically to discontinued operations; and business acquisitions included in discontinued operations.

The details of disposals of discontinued operations are as follows:

2006

In January 2007, the Trust received \$21.3 million as final payment of the working capital adjustment related to the 2005 disposition of its Energy Services and International Contract Drilling divisions to Weatherford International Ltd. ("Weatherford"). This amount had been recorded in accounts receivable at December 31, 2006 (2005 – \$20.0 million).

In August 2006, the Trust received \$4.8 million as settlement of the working capital adjustment arising from the 2005 disposal of CEDA and \$2.5 million as final payment of the contingent consideration associated with the 2004 disposal of United Diamond Ltd.

In total these amounts resulted in a gain of \$8.3 million (\$7.1 million net of tax).

2005

On August 31, 2005, the Trust sold its Energy Services and International Contract Drilling divisions to Weatherford International Ltd. for proceeds of approximately \$1.13 billion cash and 26 million common shares of Weatherford, valued at \$2.1 billion. In conjunction with the Plan of Arrangement, the Trust then distributed a total of \$2.9 billion of this consideration to Unitholders, being \$844.3 million in cash and 25.7 million Weatherford common shares, valued at \$2.0 billion which represented the fair value of the shares at the date of distribution. Included in the statement of earnings for the year ended December 31, 2005 was a loss on disposal of these shares of \$71.0 million. In conjunction with this sale, a working capital adjustment was included as part of the purchase and sale agreement. This adjustment was settled in January 2007.

In addition on September 13, 2005, the Trust sold its industrial plant maintenance business carried on by CEDA to Borealis Investments Inc., an investment entity of the Ontario Municipal Employees Retirement System, for proceeds of approximately \$274.0 million. Included in the CEDA proceeds was \$26.8 million for the purchase of CASCA Electric Ltd. and CASCA Tech Inc., a transaction undertaken by CEDA on July 29, 2005. A working capital adjustment relating to this disposal was received in August 2006.

The Energy Services, International Contract Drilling and CEDA assets were included in the Energy Services, Contract Drilling and Rental and Production segments respectively and were disposed in accordance with an extensive process undertaken by the Trust's Board of Directors to investigate avenues of value creation for the Trust's Unitholders.

2004

On February 12, 2004, the Trust sold substantially all of the assets of Fleet Cementers, Inc. for proceeds of \$25.7 million. On May 7, 2004, the Trust sold the assets of the Polar Completions division for proceeds of \$15.0 million, subject to working capital adjustments. On August 31, 2004, the Trust sold its 65% interest in United Diamond Ltd. for proceeds of \$8.5 million. Additional proceeds in the amount of up to \$9.5 million was receivable with respect to the sale of United Diamond Ltd., contingent upon the extent of future business undertaken between the Trust and United Diamond Ltd. In August 2006 this adjustment was finalized. These assets were included in the Energy Services segment and were disposed of as they were not a core component, at that time, to the energy services globalization strategy.

Results of the operations of these businesses have been classified as results of discontinued operations.

The following table provides additional information with respect to amounts included in the statements of earnings related to discontinued operations:

	2006	2005	2004
Revenue:			
Energy services	\$ —	\$ 689,319	\$ 898,199
International contract drilling	—	204,987	246,612
Industrial plant maintenance (CEDA)	—	149,371	175,802
	<u>\$ —</u>	<u>\$ 1,043,677</u>	<u>\$ 1,320,613</u>
Gain (loss) on disposal:			
Loss on disposal of Fleet Cementers' assets	\$ —	\$ —	\$ (362)
Gain (loss) on disposal of United Diamond	2,070	—	(254)
Gain on disposal of Energy services and International contract drilling	962	1,203,309	—
Gain on disposal of Industrial plant maintenance	4,045	132,073	—
	<u>7,077</u>	<u>1,335,382</u>	<u>(616)</u>
Results of operations before income taxes:			
Energy services	—	76,607	33,060
International contract drilling	—	41,171	65,043
Industrial plant maintenance	—	18,135	19,658
Other	—	(22,298)	(20,251)
Writedown of assets held for sale	—	—	(6,117)
	<u>—</u>	<u>113,615</u>	<u>91,393</u>
Income tax expense	—	39,282	28,824
Results of operations, before non-controlling interest	—	74,333	62,569
Non-controlling interest	—	—	2,680
Results of operations	<u>—</u>	<u>74,333</u>	<u>59,889</u>
Net earnings of discontinued operations	<u>\$ 7,077</u>	<u>\$ 1,409,715</u>	<u>\$ 59,273</u>

The following table provides additional information with respect to amounts included in the statements of cash flow related to discontinued operations:

	2006	2005	2004
Net earnings of discontinued operations	\$ 7,077	\$ 1,409,715	\$ 59,273
Items not affecting cash:			
(Gain) loss on disposal of discontinued operations	(7,077)	(1,335,382)	616
Depreciation and amortization	—	95,794	130,163
Writedown of assets of discontinued operations	—	—	3,293
Stock-based compensation	—	10,109	5,647
Future income taxes	—	(1,735)	(17,383)
Unrealized foreign exchange loss on long-term monetary items	—	4,829	2,729
Non-controlling interest	—	—	2,680
Funds provided by discontinued operations	<u>\$ —</u>	<u>\$ 183,330</u>	<u>\$ 187,018</u>

Components of changes in non-cash working capital balances of discontinued operations:

	2006	2005	2004
Accounts receivable	\$ —	\$ (60,912)	\$ (93,743)
Inventory	—	(23,463)	5,725
Accounts payable and accrued liabilities	—	1,688	52,861
Income taxes payable	—	(3,623)	8,360
	<u>\$ —</u>	<u>\$ (86,310)</u>	<u>\$ (26,797)</u>

Significant accounting policies relating to discontinued operations included:

(a) Employee benefit plans

At December 31, 2004, approximately 36% of employees of discontinued operations were enrolled in retirement plans. Of that, approximately 6% of participating employees were enrolled in the defined benefit plan and approximately 94% in the defined contribution plan.

Employer contributions to defined contribution plans were expensed as employees earned the entitlement and contributions were made.

The Trust accrued the cost of pensions earned by employees under its defined benefit plan, which was actuarially determined using the projected benefit method pro-rated on services and management's best estimate of expected plan investment performance, salary escalation and retirement ages of employees. For the purpose of calculating the expected return on plan assets, those assets were valued at quoted market value at the balance sheet date. The discount rate used to calculate the interest cost on the accrued benefit obligation was the long-term market rate at the balance sheet date. Past service costs from plan amendments were amortized on a straight-line basis over the average remaining service period of employees active at the date of amendment (EARSL). The excess of the net cumulative unamortized actuarial gain or loss over 10% of the greater of the accrued benefit obligation and the market value of plan assets was amortized over EARSL.

(b) Foreign currency translation

Accounts of the Trust's self-sustaining operations were translated to Canadian dollars using average exchange rates for the year for revenue and expenses. Assets and liabilities were translated at the year-end current exchange rate.

Gains or losses resulting from these translation adjustments were included in the cumulative translation account in Unitholders' equity.

Gains and losses arising on translation of long-term debt designated as a hedge of self-sustaining foreign operations were deferred and included in the cumulative translation account in Unitholders' equity on a net of tax basis.

(c) Hedging relationships

The Trust utilized foreign currency long-term debt to hedge its exposure to changes in the carrying values of the Trust's net investment in certain self-sustaining foreign operations as a result of changes in foreign exchange rates.

To be accounted for as a hedge, the foreign currency long-term debt must be designated and documented as a hedge, and must be effective at inception and on an ongoing basis. The documentation defined the relationship between the foreign currency long-term debt and the net investment in the foreign operations, as well as the Trust's risk management objective and strategy for undertaking the hedging transaction. The Trust formally assessed, both at the hedge's inception and on an ongoing basis, whether the changes in fair value of the foreign currency long-term debt was highly effective in offsetting changes in the fair value of the net investment in the foreign operations. If the hedging relationship was terminated or ceased to be effective, hedge accounting was not applied to subsequent gains or losses. Any previously deferred amounts were carried forward and recognized in earnings in the same period as the hedged item.

(d) Research and engineering

Research and engineering costs were charged to income as incurred. Costs associated with the development of new operating tools and systems were expensed during the period unless the recovery of these costs could be reasonably assured given the existing and anticipated future industry conditions. Upon successful completion and field testing of the tools, any deferred costs were transferred to the related capital asset accounts.

The details of business acquisitions included in discontinued operations are as follows:

2005

On July 29, 2005, the Trust completed the acquisition of all the issued and outstanding shares of CASCA Electric Ltd. and CASCA Tech Inc. for \$30.4 million. No value was assigned to intangibles or goodwill.

2004

During the year ended December 31, 2004, in accordance with the Trust's then globalization and technology advancement strategies, the Trust completed several acquisitions, the most significant of which were:

- (a) On May 14, 2004, the Trust acquired all of the issued and outstanding shares of Reeves Oilfield Services Ltd. (Reeves), including a 56.5% interest in Allegheny Wireline Services, Inc. (Allegheny). On October 14, 2004, the Trust acquired the remaining 43.5% interest in Allegheny. In the intervening period from the date of acquisition of Reeves to the acquisition of the remaining interest in Allegheny, earnings attributable to non-controlling interest totaled \$1.3 million. Reeves provided open hole and cased hole logging services to the oil and gas industry with operations in Canada, the United States, Australia, Africa, Europe and the Middle East. Intangible assets acquired relate entirely to intellectual property.
- (b) On May 21, 2004, the Trust acquired land drilling assets, located in Venezuela and the Middle East, from GlobalSantaFe Corporation (GlobalSantaFe). Intangible assets acquired relate to non-competition agreements and customer contracts.

	Reeves	GlobalSantaFe	Other	Total
Net assets acquired at assigned values:				
Working capital	\$ 23,000 ⁽¹⁾	\$ 12,463	\$ 60	\$ 35,523
Intangible assets	106,900	33,138	–	140,038
Property, plant and equipment	41,730	296,655	1,547	339,932
Goodwill (no tax basis)	118,531	103,956	130	222,617
Non-controlling interest in earnings of intervening period	1,298	–	–	1,298
Future income taxes	(37,732)	(9,720)	–	(47,452)
	<u>\$ 253,727</u>	<u>\$ 436,492</u>	<u>\$ 1,737</u>	<u>\$ 691,956</u>
Consideration:				
Cash	\$ 253,727	\$ 436,492	\$ 1,737	\$ 691,956

(1) Includes cash of \$12,142

UNIT TRADING SUMMARY – 2006

The Toronto Stock Exchange (TSX)

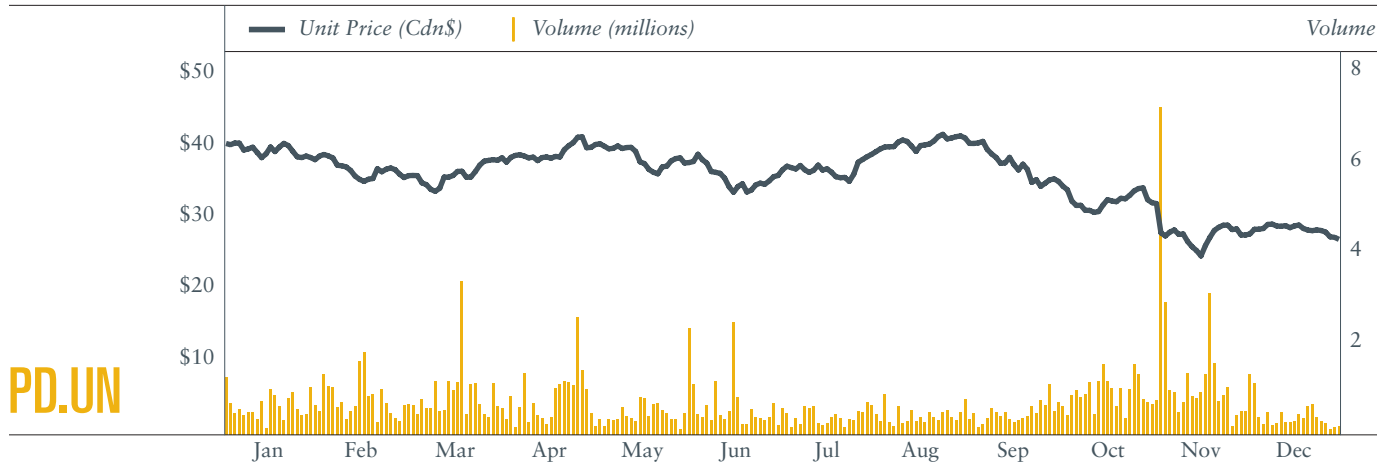

The New York Stock Exchange (NYSE)

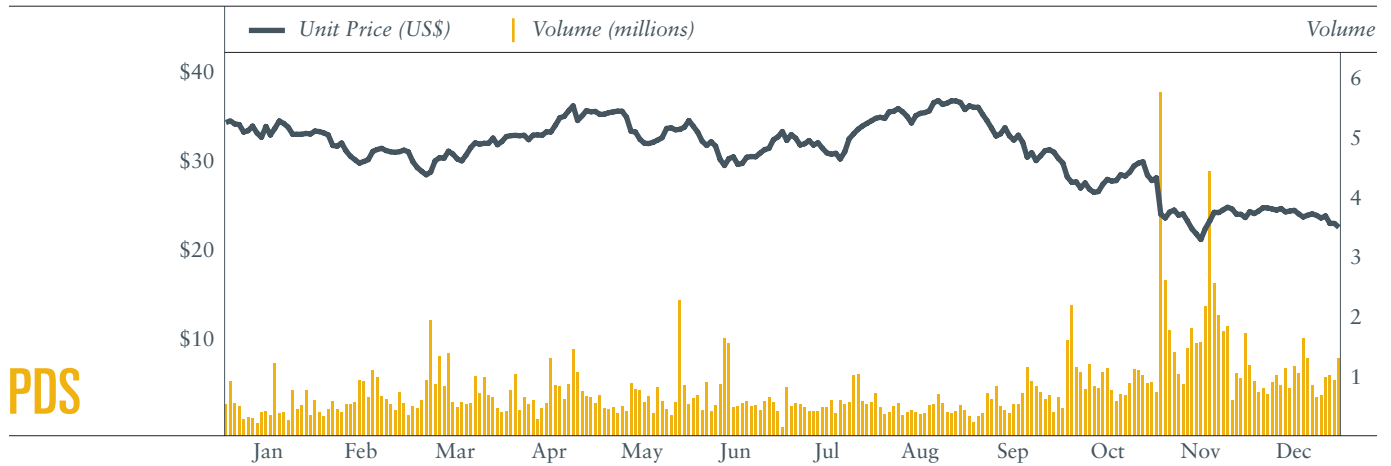

CONSOLIDATED STATEMENTS OF EARNINGS AND RETAINED EARNINGS (DEFICIT)

Years ended
December 31,

(Stated in millions of Canadian dollars,
except per unit/share amounts)

	2006	2005	2004	2003
Revenue	\$ 1,437.6	\$ 1,269.2	\$ 1,028.5	\$ 915.2
Expenses:				
Operating	688.2	641.8	566.3	544.2
General and administrative	81.2	76.4	64.2	42.7
Depreciation and amortization	73.2	71.6	74.8	78.1
Foreign exchange	(0.3)	(3.5)	(8.1)	(2.2)
Reorganization costs	–	17.5	–	–
Operating earnings	595.3	465.4	331.3	252.4
Interest, net	8.0	29.3	46.3	34.0
Premium on redemption of bonds	–	71.9	–	–
Loss on disposal of short-term investments	–	71.0	–	–
Other	(0.4)	–	(4.9)	(1.5)
Earnings from continuing operations before income taxes	587.7	293.2	289.9	219.9
Income taxes	15.2	72.4	101.8	75.7
Earnings from continuing operations	572.5	220.8	188.1	144.2
Discontinued operations, net of tax	7.1	1,409.8	59.3	36.3
Net earnings	579.6	1,630.6	247.4	180.5
Retained earnings (deficit), beginning of year	(303.3)	1,041.7	794.3	613.8
Adjustment on cash purchase of employee stock options, net of tax	–	(42.1)	–	–
Reclassification from contributed surplus on cash buy-out of employee stock options	–	23.2	–	–
Distribution of disposal proceeds	–	(2,851.8)	–	–
Repurchase of common shares of dissenting shareholders	–	(34.4)	–	–
Distributions declared	(471.5)	(70.5)	–	–
Retained earnings (deficit), end of year	\$ (195.2)	\$ (303.3)	\$ 1,041.7	\$ 794.3
Earnings per unit/share from continuing operations:				
Basic (\$)	4.56	1.79	1.63	1.33
Diluted (\$)	4.56	1.76	1.61	1.31
Earnings per unit/share:				
Basic (\$)	4.62	13.22	2.14	1.66
Diluted (\$)	4.62	13.00	2.11	1.63

ADDITIONAL SELECTED FINANCIAL INFORMATION

Years ended December 31,	(Stated in millions of Canadian dollars, except per unit/share amounts)	2006	2005	2004	2003
Return on sales – % (1)		39.8	17.4	18.3	15.8
Return on assets – % (2)		33.6	43.3	7.3	6.3
Return on equity – % (3)		49.4	66.1	12.3	11.0
Working capital	\$	166.5	\$ 152.8	\$ 557.3	\$ 249.0
Current ratio		1.81	1.43	2.47	1.57
PP&E and intangibles	\$	1,108.0	\$ 944.4	\$ 898.1	\$ 887.7
Total assets	\$	1,761.2	\$ 1,718.9	\$ 3,852.0	\$ 2,932.0
Long-term debt	\$	140.9	\$ 96.8	\$ 718.9	\$ 399.4
Unitholders' equity	\$	1,217.1	\$ 1,074.6	\$ 2,321.7	\$ 1,745.3
Long-term debt to long-term debt plus equity		0.10	0.08	0.24	0.19
Interest coverage (4)		74.1	15.9	7.2	7.4
Net capital expenditures from continuing operations excluding business acquisitions	\$	233.7	\$ 140.1	\$ 113.9	\$ 84.9
EBITDA (5)	\$	668.5	\$ 536.9	\$ 406.1	\$ 330.6
EBITDA – % of revenue		46.5	42.3	39.5	36.1
Operating earnings	\$	595.3	\$ 465.4	\$ 331.3	\$ 252.4
Operating earnings – % of revenue		41.4	36.7	32.2	27.6
Cash flow from continuing operations	\$	609.7	\$ 206.0	\$ 286.4	\$ 200.9
Cash flow from continuing operations per unit/share					
Basic	\$	4.86	\$ 1.67	\$ 2.48	\$ 1.85
Diluted	\$	4.86	\$ 1.64	\$ 2.44	\$ 1.82
Book value per unit/share (6)	\$	9.68	\$ 8.57	\$ 19.10	\$ 15.91
Price earnings ratio (7)		5.84	2.90	17.6	17.1
Basic weighted average units/shares outstanding (000's)		125,545	123,304	115,654	108,860

(1) Return on sales was calculated by dividing earnings from continuing operations by total revenues.

(2) Return on assets was calculated by dividing net earnings by quarter average total assets.

(3) Return on equity was calculated by dividing net earnings by quarter average total unitholders' equity.

(4) Interest coverage was calculated by dividing operating earnings by net interest expense.

(5) Earnings before net interest, taxes, depreciation, amortization, non-controlling interest, premium on redemption of bonds, gain/loss on disposal of investments and discontinued operations. EBITDA is not a recognized measure under Canadian GAAP. Management believes that in addition to net earnings, EBITDA is a useful supplemental measure as it provides an indication of the results generated by the Trust's principal business activities prior to consideration of how those activities are financed or how the results are taxed in various jurisdictions and prior to the impact of depreciation and amortization. Investors should be cautioned, however, that EBITDA should not be construed as an alternative to net earnings determined in accordance with GAAP as an indicator of Precision's performance. Precision's method of calculating EBITDA may differ from other companies and, accordingly, EBITDA may not be comparable to measures used by other companies.

(6) Book value per unit/share was calculated by dividing unitholders' equity by units/shares outstanding.

(7) Year end closing price divided by basic earnings per unit/share.

UNITHOLDER INFORMATION

STOCK EXCHANGE LISTINGS

Units of Precision Drilling Trust are listed on the Toronto Stock Exchange under the trading symbol PD.UN and on the New York Stock Exchange under the trading symbol PDS.

VOTING RIGHTS

Unitholders receive one vote for each Trust unit or Precision Drilling Limited Partnership Class B limited partnership unit held.

TRUST UNIT TRADING PROFILE

Toronto (TSX: PD.UN)

January 1, 2006 to December 31, 2006:

High: \$43.40, Low: \$24.40

Volume Traded: 173,386,554

New York (NYSE: PDS)

January 1, 2006 to December 31, 2006:

High: US\$38.20, Low: US\$21.46

Volume Traded: 195,284,300

ACCOUNT QUESTIONS

As a Precision Drilling Trust unitholder or as a holder of Class B limited partnership units of Precision Drilling Limited Partnership which are exchangeable on a one for one basis with units of the Trust, you are invited to take advantage of unitholder services or to request more information about Precision.

Precision's Transfer Agent can help you with a variety of unitholder related services, including:

- Change of address
- Lost unit certificates
- Transfer of trust units to another person
- Estate settlement

You can call Precision's Transfer Agent toll free at: 1-800-564-6253

You can write to our Transfer Agent at:
Computershare Trust Company of Canada
100 University Avenue, 9th Floor
Toronto, Ontario M5J 2Y1

Or you can email our Transfer Agent at: service@computershare.com

Unitholders of record who receive more than one copy of this annual report can contact our Transfer Agent and arrange to have their accounts consolidated. Unitholders who own Precision Drilling Trust units through a brokerage firm can contact their broker to request consolidation of their accounts.

QUARTERLY UPDATES

If you would like to receive interim reports but are not a registered unitholder, please write or call Precision with your name and address. To receive news releases by fax, please forward your fax number to Precision.

ONLINE INFORMATION

To receive Precision's news releases by email, or to view this annual report online, please visit Precision's website at www.precisiondrilling.com and refer to the Investor Relations section.

PUBLISHED INFORMATION

If you wish to receive copies of the 2006 Annual Information Form as filed with the Canadian securities commissions and as filed under Form 40-F with the United States Securities and Exchange Commission, or additional copies of this annual report, please contact:

Vice President, Corporate Services
and Corporate Secretary
Precision Drilling Corporation
4200, 150 - 6th Avenue SW
Calgary, Alberta T2P 3Y7
Telephone: 403-716-4500
Facsimile: 403-264-0251

ESTIMATED INTERIM RELEASE DATES

2007 First Quarter – April 25, 2007

2007 Second Quarter – July 26, 2007

2007 Third Quarter – October 25, 2007

CORPORATE INFORMATION

HEAD OFFICE

Precision Drilling Trust
4200, 150 - 6th Avenue SW
Calgary, Alberta, Canada T2P 3Y7
Telephone: 403-716-4500
Facsimile: 403-264-0251
Email: info@precisiondrilling.com
www.precisiondrilling.com

TRUSTEES

Robert J.S. Gibson
Patrick M. Murray
H. Garth Wiggins
See pages 26 and 27 for biographies

DIRECTORS

W.C. (Mickey) Dunn
Brian A. Felesky, CM, Q.C.
Robert J.S. Gibson
Allen R. Hagerman
Stephen J.J. Letwin
Patrick M. Murray
Frederick W. Pheasey
Robert L. Phillips
Hank B. Swartout
H. Garth Wiggins
See pages 26 and 27 for biographies

OFFICERS

Hank B. Swartout
Executive Chairman

Gene C. Stahl
President and Chief Operating Officer

Doug J. Strong
Chief Financial Officer

Darren J. Ruhr
*Vice President, Corporate Services
and Corporate Secretary*

SENIOR MANAGEMENT

Ron Berg
*Senior Vice President, Operations
Completion and Production Services*

Doug Evasiuk
Vice President, Marketing

John Jacobsen
*Senior Vice President, Operations
Contract Drilling Services, Canada*

Rolly Marks
Vice President, Operations

Dwayne Peters
*Senior Vice President, Operations
Contract Drilling Services, United States*

Steve James
Vice President, Health, Safety and Environment

Dion Kostiuik
Vice President, Human Resources

Len Gambles
Chief Accounting Officer

Terry Sakamoto
Vice President Finance, Operations

Wane Stickland
Vice President, Finance

Carmen Marshall
In-House Counsel

LEAD BANK

Royal Bank of Canada
Calgary, Alberta

AUDITORS

KPMG LLP
Calgary, Alberta

TRANSFER AGENT AND REGISTRAR

Computershare Trust Company of Canada
Calgary, Alberta

TRANSFER POINT

Computershare Trust Company NA
Denver, Colorado



PRECISION DRILLING TRUST

4200, 150 – 6TH AVENUE SW

CALGARY, ALBERTA T2P 3Y7

T: 403-716-4500

F: 403-264-0251

WWW.PRECISIONDRILLING.COM