

2018 ANNUAL REPORT

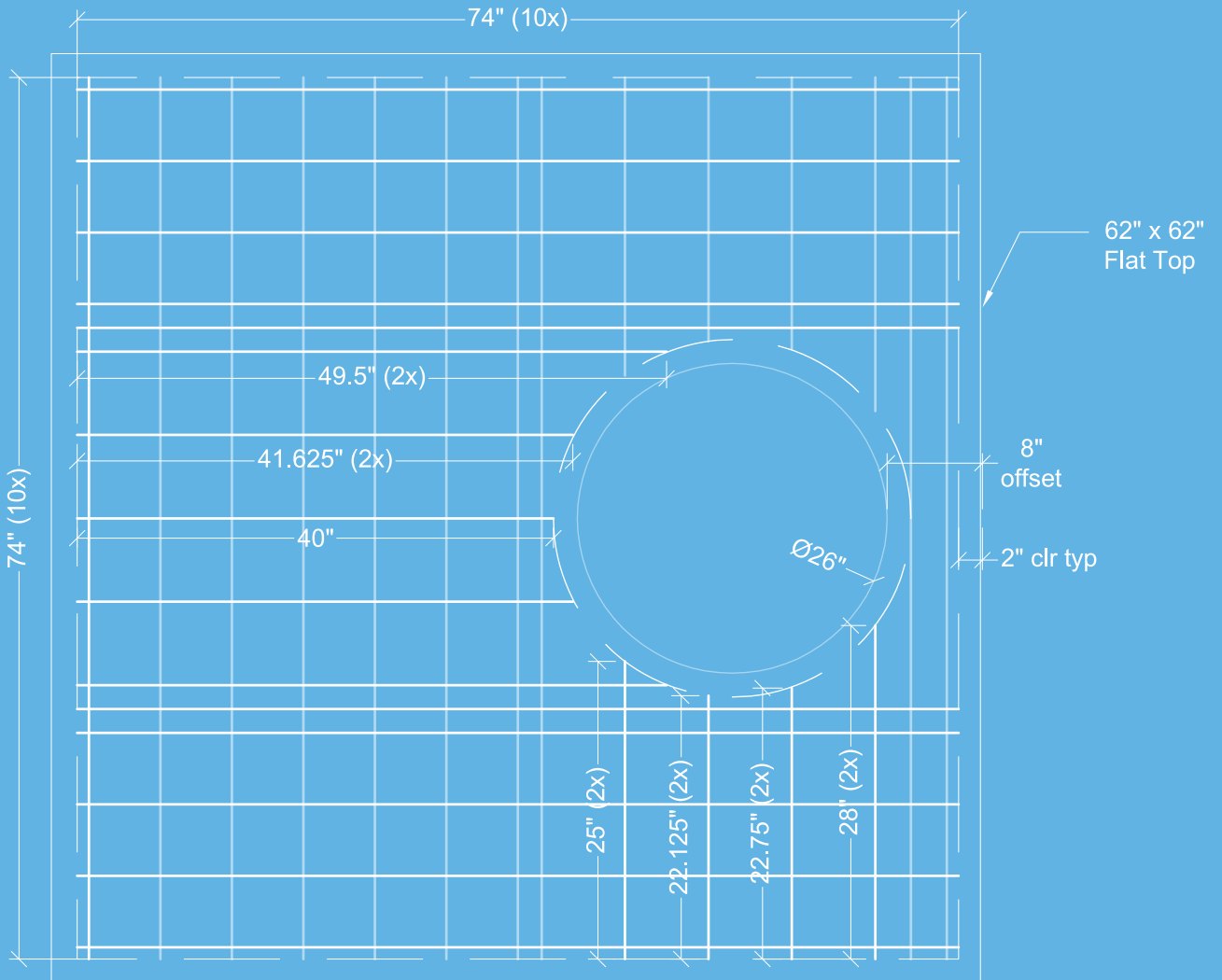

Insteel Industries is the nation's largest manufacturer of steel wire reinforcing products for concrete construction applications.

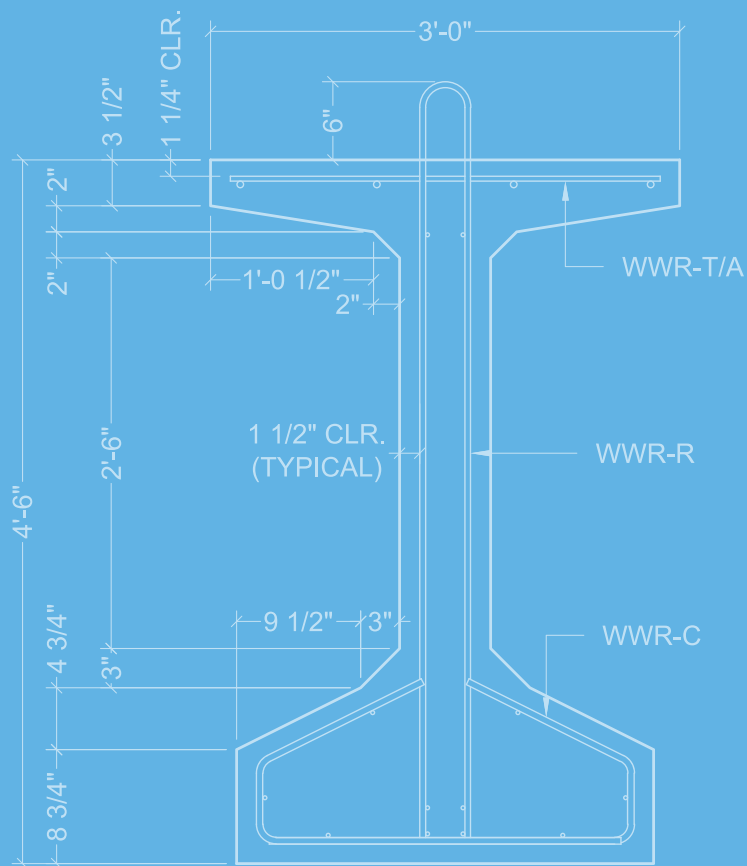

Tx54 WWR SECTION

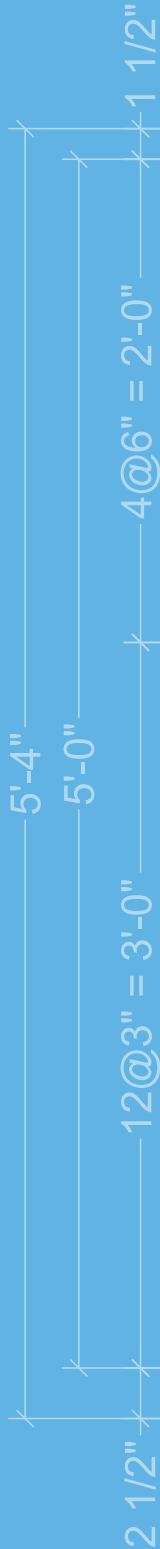

We manufacture and market prestressed concrete strand ("PC strand") and welded wire reinforcement, including engineered structural mesh, concrete pipe reinforcement and standard welded wire reinforcement. Our products are sold primarily to manufacturers of concrete products that are used in nonresidential construction. Headquartered in Mount Airy, North Carolina, we operate ten manufacturing facilities located in the United States.

FINANCIAL HIGHLIGHTS

(Dollars in thousands, except per share amounts)

	2018	2017	2016
Operating Results:			
Net sales	\$453,217	\$388,871	\$418,547
Gross profit	70,807	59,781	85,188
% of net sales	15.6%	15.4%	20.4%
Net earnings	\$36,266	\$22,548	\$37,245
% of net sales	8.0%	5.8%	8.9%
Per Share Data:			
Net earnings:			
Basic	\$1.90	\$1.19	\$1.99
Diluted	1.88	1.17	1.95
Cash dividends declared	1.12	1.37	1.12
Returns:			
Return on total capital ⁽¹⁾	15.6%	10.1%	17.5%
Return on shareholders' equity ⁽²⁾	15.6%	10.1%	17.5%
Financial Position:			
Cash and cash equivalents	\$43,941	\$32,105	\$58,873
Total assets	329,534	283,073	292,892
Total debt	-	-	-
Shareholders' equity	241,665	223,376	224,566
Cash Flows:			
Net cash provided by operating activities	\$53,969	\$20,840	\$56,253
Acquisition of business	3,300	-	-
Capital expenditures	18,449	20,575	12,977
Depreciation and amortization	12,818	11,649	11,544
Cash dividends paid	21,333	26,011	20,859

(1) Net earnings/(average total debt + average shareholders' equity).

(2) Net earnings/average shareholders' equity.

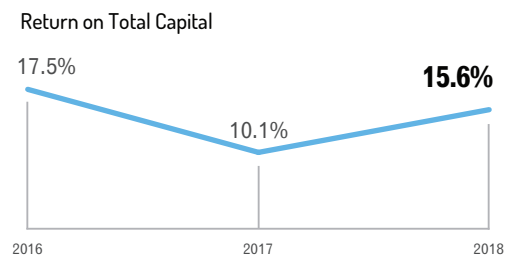
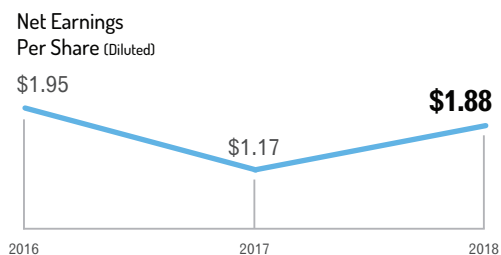
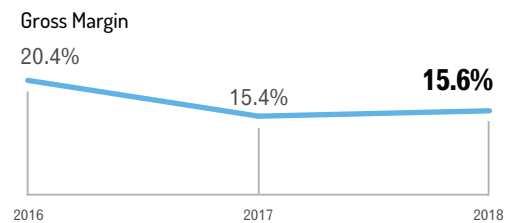

BUSINESS OVERVIEW

60% OF NET SALES

Welded Wire Reinforcement

Prefabricated reinforcement consisting of high-strength wires that are welded into specified patterns according to customer requirements, which may provide for alternative wire diameters, lengths and spacings. Wire intersections are electrically resistance-welded by computer-controlled continuous automatic welding lines that use pressure and heat to fuse longitudinal and cross wires in their proper position.

ENGINEERED STRUCTURAL MESH

Engineered made-to-order product that is used as the primary reinforcement in concrete elements or structures, frequently serving as a replacement for hot-rolled rebar.

Plant Locations

Dayton, TX | Hazleton, PA |
Jacksonville, FL | Kingman, AZ |
Mount Airy, NC | St. Joseph, MO

Customer Segments

Precast and Prestressed Producers |
Rebar Fabricators | Distributors |
Contractors

End Uses

Nonresidential Construction

CONCRETE PIPE REINFORCEMENT

Engineered made-to-order product that is used as the primary reinforcement in concrete pipe and box culverts for drainage and sewage systems, water treatment facilities and other related applications.

Plant Locations

Dayton, TX | Jacksonville, FL |
Kingman, AZ | Mount Airy, NC |
St. Joseph, MO

Customer Segments

Concrete Pipe and Precast Producers

End Uses

Nonresidential Construction |
Residential Construction

STANDARD WELDED WIRE REINFORCEMENT

Secondary reinforcing product that is produced in standard styles for crack control applications in residential and light nonresidential construction, including driveways, sidewalks and a wide range of slab-on-grade applications.

Plant Locations

Dayton, TX | Hazleton, PA | Hickman, KY |
Jacksonville, FL | Mount Airy, NC

Customer Segments

Rebar Fabricators | Distributors

End Uses

Nonresidential Construction |
Residential Construction

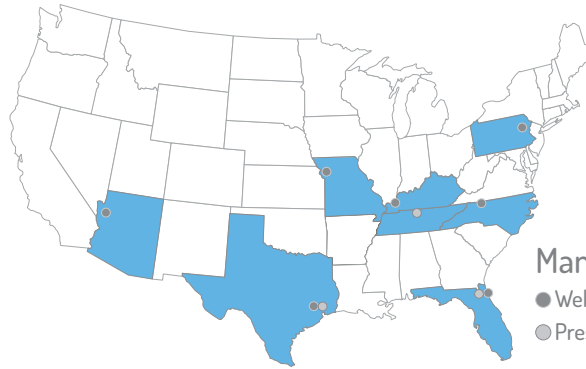

Manufacturing Locations

- Welded Wire Reinforcement
- Prestressed Concrete Strand

40% OF NET SALES

Prestressed Concrete Strand

High-strength seven-wire reinforcement consisting of six wires that are continuously wrapped around a center wire forming a strand, which is then heat-treated while under tension. Provides tensile strength and compression forces in concrete elements and structures, allowing for the use of longer, thinner and lighter spans or sections. May be used in either pretensioned or posttensioned applications to reinforce bridges, parking decks, buildings, other concrete structures and concrete slabs for new homes in regions that have expansive soil.

Plant Locations

Gallatin, TN | Houston, TX | Sanderson, FL

Customer Segments

Precast Prestress Producers |
Posttensioning Suppliers

End Uses

Nonresidential Construction |
Residential Construction

WWR-V ELEVATION
VIEW

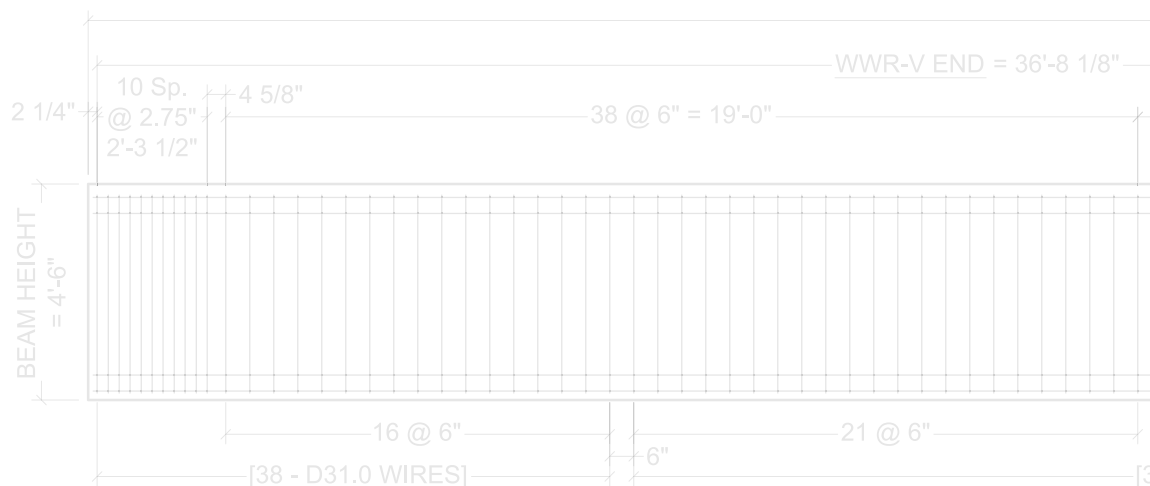

LETTER TO SHAREHOLDERS

We continued to pursue an aggressive capital expenditure program during 2018 focused on strengthening our cost leadership position, enhancing our manufacturing capabilities and expanding our ESM business.

2018 marked another year of considerable progress for Insteel in an increasingly challenging business environment. We acquired certain of the assets of Ortiz Engineered Products, Inc. ("OEP") to augment our engineering and sales infrastructure and accelerate the growth of our engineered structural mesh ("ESM") business. We continued to make strategic investments in our facilities to strengthen our low cost producer status and broaden our ESM manufacturing capabilities. We navigated through a period of escalating raw material costs in the wake of the imposition of the Section 232 tariffs on imported steel. And we maintained our strong balance sheet, providing us with the financial flexibility to pursue additional growth opportunities that may arise.

FINANCIAL RESULTS

Net sales for 2018 rose 16.5% from the prior year to \$453.2 million driven by an 11.5% increase in average selling prices and a 4.6% increase in shipments. Gross margin widened 20 basis points to 15.6% due to higher spreads between selling prices and raw material costs, and, to a lesser extent, the increase in shipments and lower unit manufacturing costs on higher production volume. The spread improvement was driven by a series of price increases that were implemented over the course of the year in response to the spike in raw material costs resulting from the Section 232 tariff program. Net earnings rose to \$36.3 million, or \$1.88 per diluted share, from \$22.5 million, or \$1.17 per diluted share, in 2017. Our results for 2018 benefited from a \$3.3 million, or \$0.17 per share gain, on the remeasurement of deferred tax assets and liabilities and a lower effective tax rate related to

the reduction in the corporate tax rate under the Tax Cuts and Jobs Act. Excluding the deferred tax gain, our effective tax rate dropped to 22.7% from 34.0% in the prior year reflecting the impact of the new tax law.

Cash flow from operations totaled \$54.0 million for the year, which was used to fund \$21.3 million of dividend payments (a special cash dividend of \$1.00 per share and regular quarterly cash dividends totaling \$0.12 per share), \$18.4 million of capital expenditures and the \$3.3 million acquisition of OEP. This marks the third consecutive year in which we paid a special dividend of at least \$1.00 per share. We ended the year debt-free with \$43.9 million of cash on hand and no borrowings outstanding on our \$100 million revolving credit facility.

OEP ACQUISITION

In November 2017, we acquired certain of the assets of OEP. OEP provides value-engineered reinforcing solutions for the concrete construction industry, converting projects that were designed with conventional rebar to welded wire reinforcement ("WWR"). The addition of OEP's engineering staff and project management capabilities should accelerate our efforts to penetrate the rebar market through the substitution of ESM for cast-in-place ("CIP") applications. Following the completion of the transaction, we successfully integrated our respective sales and engineering groups and intensified our focus on expanding our participation in the CIP market and leveraging our ESM manufacturing capabilities.

For many applications, ESM can serve as a lower cost and higher strength concrete reinforcing solution than rebar and allow contractors to compress their project timelines. The substitution of ESM eliminates the labor intensive placing and hand-tying required for the installation of rebar, making the product even more attractive on a relative basis in today's tight labor market. In addition, fewer tons of steel are generally required when using ESM over rebar due to its higher yield strength.

CAPITAL EXPENDITURE PROGRAM

We continued to pursue an aggressive capital expenditure program during 2018 focused on strengthening our cost leadership position, enhancing our manufacturing capabilities and expanding our ESM business. Capital outlays for the year were largely related to further investments in ESM production lines and ancillary equipment, the purchase of the leased Houston facility and production technology upgrades across a number of locations. The ESM investments we are making replace older equipment with the latest technology, allowing for the integration and automation of previously separate processes, increasing our productivity, broadening the range of design configurations that we can manufacture and providing additional capacity for future growth. Capital expenditures for 2019 are expected to total up to \$22 million primarily for further cost and productivity improvement initiatives that enhance our market and cost leadership positions in addition to recurring maintenance.

LOOKING AHEAD

As we move into 2019, the outlook for our construction end-markets remains positive. The leading indicators and industry forecasts for nonresidential building construction are signaling modest growth in the coming year supported by continued economic expansion. The infrastructure-related portion of our business should benefit from increased federal funding through the FAST Act and supplemental measures together

with higher state and local spending supported by various initiatives, including fuel tax increases, bond financings and the redirection of other tax revenues. We are hopeful that the Administration and Congress will be able to reach common ground on a meaningful, long-term funding package that provides for increased infrastructure investment and addresses the looming deficit in the federal highway trust fund.

Despite the favorable macro outlook, we are concerned about the market distortions resulting from the Section 232 tariff program which has driven domestic prices for our primary raw material, hot-rolled steel wire rod, well above world market levels. Considering that the tariffs were not applied to most downstream products, including WWR and PC strand, the program places us at a competitive disadvantage to foreign producers who continue to have access to steel from other markets that are not subject to the 25% tariff. During the second half of 2018, we began to see a surge in low-priced imports of PC strand and standard WWR which has eroded the market share of domestic producers and compressed margins. These unfavorable trends are likely to persist until either the 232 program is terminated or the tariffs are extended to downstream products derived from wire rod that are susceptible to import competition. We are actively engaged with the Administration and Congress to arrive at a solution that addresses the unsustainable competitive environment that has developed as a result of the tariff program and levels the playing field for domestic producers of downstream products.

We will continue to focus on our strategic priorities in optimizing our costs, improving the productivity of all of our manufacturing, selling and administrative activities, investing in our people and facilities, and fully capitalizing on the scale of our operations and the competitive advantages that are available to us. We will also pursue further synergistic acquisitions in our core businesses that create value for our shareholders.

We look forward to building on the progress that was made over the past year and to the opportunities that lie ahead. Thanks to our employees, customers and shareholders for their continued trust, confidence and support.



H.O. Woltz III
Chairman, President and
Chief Executive Officer

UNITED STATES
SECURITIES AND EXCHANGE COMMISSION
Washington, D.C. 20549

FORM 10-K

ANNUAL REPORT PURSUANT TO SECTION 13 OR 15(d) OF THE SECURITIES EXCHANGE ACT OF 1934
For the fiscal year ended September 29, 2018

OR
TRANSITION REPORT PURSUANT TO SECTION 13 OR 15(d) OF THE SECURITIES EXCHANGE ACT OF 1934
For the transition period from _____ to _____
Commission file number 1-9929



INSTEEL INDUSTRIES, INC.

(Exact name of registrant as specified in its charter)

North Carolina	56-0674867
<i>(State or other jurisdiction of incorporation or organization)</i>	<i>(I.R.S. Employer Identification No.)</i>
1373 Boggs Drive, Mount Airy, North Carolina 27030	
<i>(Address of principal executive offices) (Zip Code)</i>	
(336) 786-2141	
<i>Registrant's telephone number, including area code:</i>	

SECURITIES REGISTERED PURSUANT TO SECTION 12(b) OF THE ACT:	
Title of Each Class	Name of Each Exchange on Which Registered
Common Stock (No Par Value) (Preferred Share Purchase Rights are attached to and trade with the Common Stock)	The Nasdaq Stock Market LLC (Nasdaq Global Select Market)

SECURITIES REGISTERED PURSUANT TO SECTION 12(g) OF THE ACT:	
Preferred Share Purchase Rights (attached to and trade with the Common Stock)	
Title of Class	

Indicate by check mark	YES	NO
• if the registrant is a well-known seasoned issuer, as defined in Rule 405 of the Securities Act.	<input type="checkbox"/>	<input checked="" type="checkbox"/>
• if the registrant is not required to file reports pursuant to Section 13 or 15(d) of the Act.	<input type="checkbox"/>	<input checked="" type="checkbox"/>
• whether the registrant (1) has filed all reports required to be filed by Section 13 or 15(d) of the Securities Exchange Act of 1934 during the preceding 12 months (or for such shorter period that the registrant was required to file such reports), and (2) has been subject to such filing requirements for the past 90 days.	<input checked="" type="checkbox"/>	<input type="checkbox"/>
• whether the registrant has submitted electronically every Interactive Data File required to be submitted pursuant to Rule 405 of Regulation S-T (§232.405 of this chapter) during the preceding 12 months (or for such shorter period that the registrant was required to submit such files).	<input checked="" type="checkbox"/>	<input type="checkbox"/>
• if disclosure of delinquent filers pursuant to Item 405 of Regulation S-K is not contained herein, and will not be contained, to the best of registrant's knowledge, in definitive proxy or information statements incorporated by reference in Part III of this Form 10-K or any amendment to the Form 10-K.	<input checked="" type="checkbox"/>	<input type="checkbox"/>
• whether the registrant is a large accelerated filer, an accelerated filer, a non-accelerated filer, a smaller reporting company or an emerging growth company. See the definitions of "large accelerated filer", "accelerated filer", "smaller reporting company" and "emerging growth company" in Rule 12b-2 of the Exchange Act. (Check one):		
Large accelerated filer <input type="checkbox"/>	Accelerated filer <input checked="" type="checkbox"/>	Non-accelerated filer <input type="checkbox"/>
	Smaller reporting company <input type="checkbox"/>	Emerging growth company <input type="checkbox"/>
• If an emerging growth company, indicate by check mark if the registrant has elected not to use the extended transition period for complying with any new or revised financial accounting standards provided pursuant to Section 13(a) of the Exchange Act.	<input type="checkbox"/>	
• whether the registrant is a shell company (as defined in Rule 12b-2 of the Act).	<input type="checkbox"/>	<input checked="" type="checkbox"/>

As of March 31, 2018 (the last business day of the registrant's most recently completed second quarter), the aggregate market value of the common stock held by non-affiliates of the registrant was \$437,197,613 based upon the closing sale price as reported on the Nasdaq Global Select Market. As of October 25, 2018, there were 19,222,479 shares of the registrant's common stock outstanding.

DOCUMENTS INCORPORATED BY REFERENCE

Certain portions of the registrant's proxy statement to be delivered to shareholders in connection with the 2019 Annual Meeting of Shareholders are incorporated by reference as set forth in Part III hereof.

Table of Contents

Cautionary Note Regarding Forward-Looking Statements	4
PART I	5
Item 1 Business	5
Item 1A Risk Factors	8
Item 1B Unresolved Staff Comments	10
Item 2 Properties	10
Item 3 Legal Proceedings	10
Item 4 Mine Safety Disclosures	10
Executive Officers of the Company	11
PART II	12
Item 5 Market for the Registrant’s Common Equity, Related Shareholder Matters and Issuer Purchases of Equity Securities	12
Item 6 Selected Financial Data	14
Item 7 Management’s Discussion and Analysis of Financial Condition and Results of Operations	14
Item 7A Quantitative and Qualitative Disclosures About Market Risk	22
Item 8 Financial Statements and Supplementary Data	23
Item 9 Changes in and Disagreements with Accountants on Accounting and Financial Disclosure	46
Item 9A Controls and Procedures	46
Item 9B Other Information	48
PART III	48
Item 10 Directors, Executive Officers and Corporate Governance	48
Item 11 Executive Compensation	48
Item 12 Security Ownership of Certain Beneficial Owners and Management and Related Stockholder Matters	48
Item 13 Certain Relationships and Related Transactions, and Director Independence	48
Item 14 Principal Accounting Fees and Services	49
PART IV	49
Item 15 Exhibits, Financial Statement Schedules	49
Item 16 Form 10-K Summary	49
Exhibit Index	50
Signatures	52

Cautionary Note Regarding Forward-Looking Statements

This report contains forward-looking statements within the meaning of the safe harbor provisions of the Private Securities Litigation Reform Act of 1995, particularly in the “Business,” “Risk Factors” and “Management’s Discussion and Analysis of Financial Condition and Results of Operations” sections of this report. When used in this report, the words “believes,” “anticipates,” “expects,” “estimates,” “appears,” “plans,” “intends,” “may,” “should,” “could” and similar expressions are intended to identify forward-looking statements. Although we believe that our plans, intentions and expectations reflected in or suggested by such forward-looking statements are reasonable, they are subject to a number of risks and uncertainties, and we can provide no assurances that such plans, intentions or expectations will be implemented or achieved. Many of these risks and uncertainties are discussed in the “Risk Factors” section of this report and are updated from time to time in our filings with the United States (“U.S.”) Securities and Exchange Commission (“SEC”).

All forward-looking statements attributable to us or persons acting on our behalf are expressly qualified in their entirety by these cautionary statements. All forward-looking statements speak only to the respective dates on which such statements are made, and we do not undertake any obligation to publicly release the results of any revisions to these forward-looking statements that may be made to reflect any future events or circumstances after the date of such statements or to reflect the occurrence of anticipated or unanticipated events, except as may be required by law.

It is not possible to anticipate and list all risks and uncertainties that may affect our future operations or financial performance; however, they include, but are not limited to, the following:

- general economic and competitive conditions in the markets in which we operate;
- changes in the spending levels for nonresidential and residential construction and the impact on demand for our products;
- changes in the amount and duration of transportation funding provided by federal, state and local governments and the impact on spending for infrastructure construction and demand for our products;
- the cyclical nature of the steel and building material industries;
- credit market conditions and the relative availability of financing for us, our customers and the construction industry as a whole;
- fluctuations in the cost and availability of our primary raw material, hot-rolled carbon steel wire rod, from domestic and foreign suppliers;
- competitive pricing pressures and our ability to raise selling prices in order to recover increases in raw material or operating costs;
- changes in U.S. or foreign trade policy affecting imports or exports of steel wire rod or our products;
- unanticipated changes in customer demand, order patterns and inventory levels;
- the impact of fluctuations in demand and capacity utilization levels on our unit manufacturing costs;
- our ability to further develop the market for engineered structural mesh (“ESM”) and expand our shipments of ESM;
- legal, environmental, economic or regulatory developments that significantly impact our operating costs;
- unanticipated plant outages, equipment failures or labor difficulties; and
- the risks and uncertainties discussed herein under the caption “Risk Factors.”

PART I

Item 1 Business

General

Insteel Industries, Inc. (“we,” “us,” “our,” “the Company” or “Insteel”) is the nation’s largest manufacturer of steel wire reinforcing products for concrete construction applications. We manufacture and market prestressed concrete strand (“PC strand”) and welded wire reinforcement (“WWR”), including ESM, concrete pipe reinforcement (“CPR”) and standard welded wire reinforcement (“SWWR”). Our products are sold primarily to manufacturers of concrete products that are used in nonresidential construction. For fiscal 2018, we estimate that approximately 85% of our sales were related to nonresidential construction and 15% were related to residential construction.

Insteel is the parent holding company for two wholly-owned subsidiaries, Insteel Wire Products Company (“IWP”), an operating subsidiary, and Intercontinental Metals Corporation, an inactive

subsidiary. We were incorporated in 1958 in the State of North Carolina.

Our business strategy is focused on: (1) achieving leadership positions in our markets; (2) operating as the lowest cost producer in our industry; and (3) pursuing growth opportunities within our core businesses that further our penetration of the markets we currently serve or expand our footprint. Headquartered in Mount Airy, North Carolina, we operate ten manufacturing facilities that are all located in the U.S. in close proximity to our customers and raw material suppliers. Our growth strategy is focused on organic opportunities as well as acquisitions in existing or related markets that leverage our infrastructure and core competencies in the manufacture and marketing of concrete reinforcing products.

Products

Our operations are entirely focused on the manufacture and marketing of steel wire reinforcing products for concrete construction applications. Our concrete reinforcing products consist of two product lines: PC strand and WWR. Based on the criteria specified in Financial Accounting Standards Board (“FASB”) Accounting Standards Codification (“ASC”) Topic 280, Segment Reporting, we have one reportable segment. Our net sales and long-lived assets by geographic region are discussed in Note 13 to our consolidated financial statements and incorporated herein by reference.

PC strand is a high strength, seven-wire strand that is used to impart compression forces into precast concrete elements and structures, which may be either pretensioned or posttensioned, providing reinforcement for bridges, parking decks, buildings and other concrete structures. Its high tensile strength allows for the casting of longer spans and thinner sections. Pretensioned or “prestressed” concrete elements or structures are primarily used in nonresidential construction while posttensioned concrete elements or structures are used in both nonresidential and

residential construction. For fiscal years 2018, 2017 and 2016, PC strand sales represented 40%, 38% and 39%, respectively, of our net sales.

WWR is produced as either a standard or a specially engineered reinforcing product for use in nonresidential and residential construction. We produce a full range of WWR products, including ESM, CPR and SWWR. ESM is an engineered made-to-order product that is used as the primary reinforcement for concrete elements or structures, frequently serving as a lower cost reinforcing solution than hot-rolled rebar. CPR is an engineered made-to-order product that is used as the primary reinforcement in concrete pipe, box culverts and precast manholes for drainage and sewage systems, water treatment facilities and other related applications. SWWR is a secondary reinforcing product that is produced in standard styles for crack control applications in residential and light nonresidential construction, including driveways, sidewalks and various slab-on-grade applications. For fiscal years 2018, 2017 and 2016, WWR sales represented 60%, 62% and 61%, respectively, of our net sales.

Marketing and Distribution

We market our products through sales representatives who are our employees. Our outside sales representatives are trained on the technical applications for our products and sell multiple product lines in their respective territories. We sell our products nationwide across the U.S. and, to a much lesser extent, into

Canada, Mexico, and Central and South America, delivering them primarily by truck, using common or contract carriers. The delivery method selected is dependent upon backhaul opportunities, comparative costs and customer service requirements.

Customers

We sell our products to a broad range of customers that includes manufacturers of concrete products, and to a lesser extent, distributors, rebar fabricators and contractors. In fiscal 2018, we estimate that approximately 70% of our net sales were to manufacturers of concrete products and 30% were to distributors, rebar fabricators and contractors. In many cases we are unable to identify the specific end use for our products as most of our

customers sell products that are used for both nonresidential and residential construction, and the same products can be used for different end uses. We did not have any customers that represented 10% or more of our net sales in fiscal years 2018, 2017 and 2016. The loss of a single customer or a few customers would not have a material adverse effect on our business.

Backlog

Backlog for our business is minimal due to the relatively short lead times that are required by our customers. We believe that the majority of our firm orders as of the end of fiscal 2018 will be shipped during the first quarter of fiscal 2019.

Seasonality and Cyclicity

Demand in our markets is both seasonal and cyclical, driven by the level of construction activity, but can also be impacted by fluctuations in the inventory positions of our customers. From a seasonal standpoint, shipments typically reach their highest level of the year when weather conditions are the most conducive to construction activity. As a result, assuming normal seasonal weather patterns, shipments and profitability are usually higher

in the third and fourth quarters of the fiscal year and lower in the first and second quarters. From a cyclical standpoint, construction activity and demand for our products is generally correlated with overall economic conditions, although there can be significant differences between the relative strength of nonresidential and residential construction for extended periods.

Raw Materials

The primary raw material used to manufacture our products is hot-rolled carbon steel wire rod, which we purchase from both domestic and foreign suppliers and can generally be characterized as a commodity product. We purchase several different grades and sizes of wire rod with varying specifications based on the diameter, chemistry, mechanical properties and metallurgical characteristics that are required for our products. High carbon grades of wire rod are required for the production of PC strand while low carbon grades are used to manufacture WWR.

Wire rod prices tend to fluctuate based on changes in scrap and other metallic prices for steel producers together with domestic and global market conditions. In most economic environments, domestic demand for wire rod exceeds domestic production capacity and imports of wire rod are necessary to satisfy the supply requirements of the U.S. market. Trade actions initiated by the U.S. government or domestic wire rod producers can significantly impact the pricing and availability of imported wire rod, which during fiscal years 2018 and 2017 represented approximately 14% and 27%, respectively, of our total wire rod

purchases. We believe that our substantial wire rod requirements, desirable mix of sizes and grades, and strong financial condition represent a competitive advantage by making us a relatively more attractive customer to our suppliers.

Our ability to source wire rod from overseas suppliers is limited by domestic content requirements generally referred to as “Buy America” or “Buy American” laws that exist at both the federal and state levels. These laws generally prescribe a domestic “melt and cast” standard for purposes of compliance. Certain segments of the PC strand market and the majority of our CPR and ESM products are certified to customers to be in compliance with the domestic content regulations.

Selling prices for our products tend to be correlated with changes in wire rod prices. However, the timing and magnitude of the relative price changes varies depending upon market conditions and competitive factors. Ultimately the relative supply - demand balance in our markets and competitive dynamics determine whether our margins expand or contract during periods of rising or falling wire rod prices.

Competition

We are the nation’s largest manufacturer of steel wire reinforcing products for concrete construction applications. Our markets are highly competitive based on price, quality and service. Some of our competitors, such as Nucor Corporation, Keystone

Consolidated Industries, Inc. (“Keystone”), Oklahoma Steel and Wire, and Gerdau Long Products North America, are vertically integrated companies that produce both wire rod and concrete reinforcing products and offer multiple product lines over broad

geographic areas. Other competitors are smaller independent companies that offer limited competition in certain markets. Our primary competitors for WWR products are Engineered Wire Products, Inc. (a subsidiary of Keystone), Wire Mesh Corporation, Concrete Reinforcements, Inc., National Wire Products, Davis Wire Corporation and Oklahoma Steel & Wire Co., Inc. Our primary competitors for PC strand are Sumiden Wire Products Corporation, Keystone and Wire Mesh Corporation. Import competition is also a significant factor in certain segments of the PC strand market, and, to a lesser extent, the SWWR market that are not subject to “Buy America” requirements.

In response to irrationally-priced import competition from offshore PC strand suppliers, we have pursued trade cases when necessary as a means of ensuring that foreign producers were complying with the applicable trade laws and regulations. In 2003, we joined together with a coalition of domestic PC strand producers and filed petitions with the U.S. Department of Commerce (the “DOC”) alleging that imports of PC strand from Brazil, India, Korea, Mexico and Thailand were being “dumped” or sold in the U.S. at a price that was lower than fair value and had injured the domestic PC strand industry. The DOC ruled in our favor and imposed anti-dumping duties ranging from 12% up to 119%, which had the effect of limiting the participation of these

countries in the domestic market. In 2010, we joined together with a coalition of domestic PC strand producers and filed petitions with the DOC alleging that imports of PC strand from China were being “dumped” or sold in the U.S. at a price that was lower than fair value and that subsidies were being provided to Chinese PC strand producers by the Chinese government, both of which had injured the domestic PC strand industry. The DOC ruled in our favor and imposed final countervailing duty margins ranging from 9% to 46% and anti-dumping margins ranging from 43% to 194%, which had the effect of limiting the continued participation of Chinese producers in the domestic market.

Quality and service expectations of customers have risen substantially over the years and are key factors that impact their selection of suppliers. Technology has become a critical competitive factor from the standpoint of manufacturing costs, quality and customer service capabilities. In view of our strong market positions, broad product offering and national footprint, technologically advanced manufacturing facilities, low-cost production capabilities, sophisticated information systems and financial strength and flexibility, we believe that we are well-positioned to compete favorably with other producers of our concrete reinforcing products.

Employees

As of September 29, 2018, we had 810 employees, none of which were represented by labor unions. In the event of production disruptions, we believe that our contingency plans would enable us to continue serving our customers, although there can be no assurances that a work slowdown or stoppage would not adversely impact our operating costs and financial results.

Product Warranties

Our products are used in applications that are subject to inherent risks, including performance deficiencies, personal injury, property damage, environmental contamination or loss of production. We warrant our products to meet certain specifications. Although

actual or claimed deficiencies from these specifications may give rise to claims, we do not maintain a reserve for warranties as the historical claims have been immaterial. We maintain product liability insurance coverage to minimize our exposure to such risks.

Environmental Matters

We believe that we are in compliance in all material respects with applicable environmental laws and regulations. We have experienced no material difficulties in complying with legislative or regulatory standards and believe that these standards have not materially impacted our financial position or results of operations. Although our future compliance with additional environmental

requirements could necessitate capital outlays, we do not believe these expenditures would ultimately have a material adverse effect on our financial position or results of operations. We do not expect to incur material capital expenditures for environmental control facilities during fiscal 2019.

Available Information

Our annual report on Form 10-K, quarterly reports on Form 10-Q, current reports on Form 8-K and any amendments to these reports, are available at no cost on our web site at <https://insteelgcs.gcs-web.com/financial-information/sec-filings> and the SEC’s web site at www.sec.gov as soon as reasonably

practicable after we file these reports electronically with, or furnish them to, the SEC. The information available on our web site and the SEC’s web site is not incorporated into this report or any of our filings with the SEC.

Item 1A Risk Factors

An investment in our common stock involves risks and uncertainties. You should carefully consider the following risk factors, in addition to the other information contained in this annual report on Form 10-K, before deciding whether an investment in our common stock is suitable for you. The risk factors described below are not the only ones we face. There may be other risks and uncertainties that are currently unknown to us or that we currently consider to be immaterial that could adversely affect our business, results of operations, financial condition and cash flows.

Our business is cyclical and can be negatively impacted by prolonged economic downturns or tightening in the financial markets that reduce the level of construction activity and demand for our products.

Demand for our products is cyclical in nature and sensitive to changes in the economy and in the financial markets. Our products are sold primarily to manufacturers of concrete products that are used for a broad range of nonresidential and residential construction applications. Demand for our products is driven by the level of construction activity, which tends to be correlated with conditions in the overall economy as well as other factors beyond our control. Tightening in the financial markets could adversely impact demand for our products by reducing the availability of financing to our customers and the construction industry as a whole and increasing the risk of payment defaults on our accounts receivable. Future prolonged periods of economic weakness or reduced availability of financing could have a material adverse impact on our business, results of operations, financial condition and cash flows.

Our business can be negatively impacted by reductions in the amount and duration of government funding for infrastructure projects that reduce the level of construction activity and demand for our products.

Certain of our products are used in the construction of highways, bridges and other infrastructure projects that are funded by federal, state and local governments. Reductions in the amount of funding for such projects or the period for which it is provided could have a material adverse impact on our business, results of operations, financial condition and cash flows.

Our operations are subject to seasonal fluctuations that may impact our cash flows.

Our shipments are typically lower in the first and second fiscal quarters due to the unfavorable impact of winter weather on construction activity during these periods and customer plant shutdowns associated with holidays. As a result, our cash flows may fluctuate from quarter to quarter due to these seasonal factors.

Demand for our products is highly variable and difficult to forecast due to our minimal backlog and unanticipated changes that can occur in customer order patterns or inventory levels.

Demand for our products is highly variable. The short lead times for customer orders and minimal backlog that characterize our business make it difficult to forecast the future level of demand for our products. In some cases, unanticipated softening in demand can be exacerbated by inventory rebalancing measures pursued by our customers, which may cause significant fluctuations in our sales, profitability and cash flows.

Our financial results can be negatively impacted by the volatility in the cost and availability of our primary raw material, hot-rolled carbon steel wire rod.

The primary raw material used to manufacture our products is hot-rolled carbon steel wire rod, which we purchase from both domestic and foreign suppliers. We do not use derivative commodity instruments to hedge our exposure to changes in the price of wire rod as such instruments are currently unavailable in the financial markets. Beginning in fiscal 2004, a tightening of supply in the rod market together with fluctuations in the raw material costs of rod producers resulted in increased price volatility which has continued through fiscal 2018. In response, wire rod producers have resorted to increasing the frequency of price adjustments, typically on a monthly basis as well as unilaterally changing the terms of prior commitments.

Although changes in our wire rod costs and selling prices tend to be correlated, we may be unable to fully recover increased rod costs during weaker market environments, which would reduce our earnings and cash flows. Additionally, when raw material costs decline, our financial results may be negatively impacted if the selling prices for our products decrease to an even greater extent and if we are consuming higher cost material from inventory.

Our financial results can also be significantly impacted if raw material supplies are inadequate to satisfy our purchasing requirements. In addition, trade actions by the U.S. government, such as the imposition of the steel tariffs imposed under Section 232 of the Trade Expansion Act, as amended, or domestic wire rod producers against other countries can significantly impact the availability and cost of imported wire rod. The imposition of tariffs, quotas or anti-dumping or countervailing duty margins by the U.S. government against exporting countries can have the effect of reducing or eliminating their competitiveness and participation in the domestic market, which is of increasing importance in view of the reductions in domestic wire rod production capacity that have occurred in recent years. If we were unable to obtain adequate and timely delivery of our raw material requirements, we may be unable to manufacture sufficient quantities of our products or operate our manufacturing facilities in an efficient manner, which could result in lost sales and higher operating costs.

Foreign competition could adversely impact our financial results.

Our PC strand business, and, to a lesser extent, our SWWR business are subject to offshore import competition on an ongoing basis. If we are unable to purchase raw materials and achieve manufacturing costs that are competitive with those of foreign producers, or if the margin and return requirements of foreign producers are substantially lower, our market share and profit margins could be negatively impacted. In response to irrationally-priced import competition from offshore PC strand suppliers, we have pursued trade cases when necessary as a means of ensuring that foreign producers were complying with the applicable trade laws and regulations. These trade cases have resulted in the imposition of duties which have had the effect of limiting the continued participation of certain countries in the domestic market. Trade law enforcement is critical to our ability to maintain our competitive position against foreign PC strand and SWWR producers that engage in unlawful trade practices.

Our manufacturing facilities are subject to unexpected equipment failures, operational interruptions and casualty losses.

Our manufacturing facilities are subject to risks that may limit our ability to manufacture and sell our products, including unexpected equipment failures, operational interruptions and catastrophic losses due to other unanticipated events such as fires, explosions, accidents, adverse weather conditions and transportation interruptions. For example, during fiscal 2017, operations at our Texas and Florida plants were temporarily curtailed due to flooding and power outages related to hurricanes Harvey and Irma, and during fiscal 2018, a transformer outage and electrical fire at our Dayton, Texas plant resulted in a temporary interruption of operations. Any such equipment failures or events can subject us to material plant shutdowns, periods of reduced production or unexpected downtime. Furthermore, the resolution of certain operational interruptions may require significant capital expenditures. Although our insurance coverage could offset the losses or expenditures relating to some of these events, our results of operations and cash flows could be negatively impacted to the extent that such claims were not covered or only partially covered by our insurance.

We are increasingly dependent on information technology systems that are susceptible to certain risks, including cybersecurity breaches and data leaks, which could adversely impact our business.

Our increasing reliance on technology systems and infrastructure heightens our potential vulnerability to system failure and malfunction, breakdowns due to natural disasters, human error, unauthorized access, power loss and other unforeseen events. Data privacy breaches by employees and others with or without authorized access to our systems poses risks that sensitive data may be permanently lost or leaked to the public or other unauthorized persons. With the growing use and rapid evolution of technology, not limited to cloud-based computing and mobile devices, there are additional risks of unintentional data leaks. There

is also the risk of the theft of confidential information, intentional vandalism, industrial espionage and a variety of cyber-attacks that could compromise our internal technology system and infrastructure or result in data leaks in-house or at our third-party providers and business partners. Failures of technology or related systems, or an improper release of confidential information, could adversely impact our business or subject us to unexpected liabilities.

Our financial results could be adversely impacted by the escalation of our operating costs.

Consistent with the experience of other employers, our medical and workers' compensation costs have increased substantially in recent years and are expected to continue to rise. The Patient Protection and Affordable Care Act ("ACA") will have a significant impact on employers, health care providers, insurers and others associated with the health care industry and increase our employee health care costs. This legislation requires certain large employers like us to offer health care benefits to full-time employees or face potential annual penalties. To avoid these penalties, employers must offer health benefits providing a minimum level of coverage and limit the amount that employees are charged for the coverage. The Administration and Congress are pursuing legislative and regulatory changes that modify, repeal, replace with new legislation or otherwise invalidate all or certain portions of the ACA. The Tax Cuts and Jobs Act of 2017 effectively eliminated certain provisions of the ACA, including the individual mandate beginning in 2019. It is uncertain whether the other reform proposals being considered by the Administration and Congress will be enacted and potentially alter the full-time employee healthcare coverage requirement and reporting obligations imposed on large employers like us. We cannot predict the ultimate content, timing, or effect of any healthcare reform legislation or the impact of potential legislation or related proposals and policies on our results. Any significant increases in the costs attributable to our self-insured health and workers' compensation plans could adversely impact our business, results of operations, financial condition and cash flows.

In addition, increasing prices for freight, natural gas, electricity, fuel and consumables would adversely affect our manufacturing and distribution costs. For most of our business, we incur the transportation costs associated with the delivery of products to our customers. Although we have previously implemented numerous measures to offset the impact of increases in these costs, there can be no assurance that such actions will be effective. If we are unable to pass these additional costs through by raising our selling prices, our financial results could be adversely impacted.

Our financial results could be adversely impacted by the impairment of goodwill.

Our balance sheet includes intangible assets, including goodwill and other separately identifiable assets related to prior acquisitions, and we may acquire additional intangible assets in connection with future acquisitions. We are required to review goodwill for impairment on an annual basis, or more frequently if certain indicators of permanent impairment arise such as, among other things, a decline in our stock price and market capitalization

or a reduction in our projected operating results and cash flows. If our review indicates that goodwill has been impaired, the impaired portion would have to be written-off during that period which could have an adverse effect on our business and financial results.

Our capital resources may not be adequate to provide for our capital investment and maintenance expenditures if we were to experience a substantial downturn in our financial performance.

Our operations are capital intensive and require substantial recurring expenditures for the routine maintenance of our equipment and facilities. Although we expect to finance our business requirements through internally generated funds or from borrowings under our \$100.0 million revolving credit facility, we cannot provide any assurances these resources will be sufficient to support our business. A material adverse change in our operations or financial condition could limit our ability to borrow funds under our credit facility, which could further adversely impact our liquidity and financial condition. Any significant future acquisitions could require additional financing from external sources that may not be available on favorable terms, which could adversely impact our growth, operations, financial condition and results of operations.

Environmental compliance and remediation could result in substantially increased capital investments and operating costs.

Our business is subject to numerous federal, state and local laws and regulations pertaining to the protection of the environment that could require substantial increases in capital investments and operating costs. These laws and regulations, which are constantly evolving, are becoming increasingly stringent, and the ultimate impact of compliance is not always clearly known or determinable because regulations under some of these laws have not yet been promulgated or are undergoing revision.

Our stock price can be volatile, often in connection with matters beyond our control.

Equity markets in the U.S. have been increasingly volatile in recent years. During fiscal 2018, our common stock traded as high as \$43.78 and as low as \$24.51. There are numerous factors that could cause the price of our common stock to fluctuate significantly, including: variations in our financial results; changes in our business outlook and expectations for the construction industry; changes in market valuations of companies in our industry; and announcements by us, our competitors or industry participants that may be perceived to impact our financial results.

Item 1B Unresolved Staff Comments

None.

Item 2 Properties

Our corporate headquarters and IWP's sales and administrative offices are located in Mount Airy, North Carolina. At September 29, 2018, we operated ten manufacturing facilities located in Dayton, Texas; Gallatin, Tennessee; Hazleton, Pennsylvania; Hickman, Kentucky; Houston, Texas; Jacksonville, Florida; Kingman, Arizona; Mount Airy, North Carolina; Sanderson, Florida; and St. Joseph, Missouri.

We own all of our real estate following the exercise of the purchase option on the previously leased Houston facility in October 2017. We believe that our properties are in good operating condition and that our machinery and equipment have been well maintained. We also believe that our manufacturing facilities are suitable for their intended purposes and have capacities adequate to satisfy the current and projected demand for our products.

Item 3 Legal Proceedings

We are involved in lawsuits, claims, investigations and proceedings, including commercial, environmental and employment matters, which arise in the ordinary course of business. We do not anticipate that the ultimate cost to resolve these matters will have a material adverse effect on our financial position, results of operations or cash flows.

Item 4 Mine Safety Disclosures

Not applicable.

Executive Officers of the Company

Our executive officers are as follows:

Name	Age	Position
H.O. Woltz III	62	President, Chief Executive Officer and Chairman of the Board
Michael C. Gazmarian	59	Vice President, Chief Financial Officer and Treasurer
James F. Petelle	68	Vice President - Administration and Secretary
Richard T. Wagner	59	Vice President and General Manager of IWP

H. O. Woltz III, 62, was elected Chief Executive Officer in 1991 and has been employed by us and our subsidiaries in various capacities since 1978. He was named President and Chief Operating Officer in 1989. He served as our Vice President from 1988 to 1989 and as President of Rappahannock Wire Company, formerly a subsidiary of our Company, from 1981 to 1989. Mr. Woltz has been a Director since 1986 and also serves as President of Insteel Wire Products Company. Mr. Woltz served as President of Florida Wire and Cable, Inc., formerly a subsidiary of our Company, until its merger with Insteel Wire Products Company in 2002. Mr. Woltz serves on the Executive Committee of our Board of Directors and was elected Chairman of the Board in 2009.

Michael C. Gazmarian, 59, was elected Vice President, Chief Financial Officer and Treasurer in February 2007. He had previously served as Chief Financial Officer and Treasurer since 1994, the year he joined us. Before joining us, Mr. Gazmarian had been employed by Guardian Industries Corp., a privately-held manufacturer of glass, automotive and building products, since 1986, serving in various financial capacities.

James F. Petelle, 68, joined us in October 2006. He was elected Vice President and Assistant Secretary on November 14, 2006 and Vice President - Administration and Secretary on January 12,

2007. He was previously employed by Andrew Corporation, a publicly-held manufacturer of telecommunications infrastructure equipment, having served as Secretary from 1990 to May 2006, and Vice President - Law from 2000 to October 2006.

Richard T. Wagner, 59, joined us in 1992 and has served as Vice President and General Manager of the Concrete Reinforcing Products Business Unit of our subsidiary, Insteel Wire Products Company, since 1998. In February 2007, Mr. Wagner was appointed Vice President of the parent company, Insteel Industries, Inc. From 1977 until 1992, Mr. Wagner served in various positions with Florida Wire and Cable, Inc., a manufacturer of PC strand and galvanized strand products, which was later acquired by us in 2000.

The executive officers listed above were elected by our Board of Directors at its annual meeting held February 13, 2018 for a term that will expire at the next annual meeting or until their successors are elected and qualify. The next meeting at which officers will be elected is expected to be February 12, 2019.

PART II

Item 5 Market for Registrant's Common Equity, Related Shareholder Matters and Issuer Purchases of Equity Securities

Our common stock is listed on the Nasdaq Global Select Market under the symbol "IIN" and has been trading on Nasdaq since September 28, 2004. As of October 23, 2018, there were 550 shareholders of record. The following table summarizes the high and low sales prices as reported on the Nasdaq Global Select Market and the cash dividends per share declared in fiscal 2018 and 2017:

	Fiscal 2018			Fiscal 2017		
	High	Low	Cash Dividends	High	Low	Cash Dividends
First Quarter	\$ 29.65	\$ 24.51	\$ 1.03	\$ 42.81	\$ 22.50	\$ 1.28
Second Quarter	34.32	27.00	0.03	39.20	32.22	0.03
Third Quarter	35.60	26.05	0.03	36.94	28.94	0.03
Fourth Quarter	43.78	32.75	0.03	34.00	23.20	0.03

In addition to our regular quarterly cash dividend of \$0.03 per share, we declared special cash dividends of \$1.00 per share in the first quarter of fiscal 2018 and \$1.25 per share in the first quarter of fiscal 2017. While we intend to pay regular quarterly cash dividends for the foreseeable future, the declaration and payment of future dividends, if any, are discretionary and will be subject to determination by our Board of Directors after taking into

account various factors, including general business conditions and our financial condition, operating results, cash requirements and expansion plans. See Note 7 to the consolidated financial statements for additional discussion with respect to restrictions on our ability to make dividend payments under the terms of our revolving credit facility.

Stock Performance Graph

The graph below compares the cumulative total shareholder return on our common stock with the cumulative total return of the Russell 2000 Index and the S&P Building Products Index for the five years ended September 29, 2018. The graph and table assume that \$100 was invested on September 28, 2013

in our common stock and in each of the two indices and the reinvestment of all dividends. Cumulative total shareholder returns for our common stock, the Russell 2000 Index and the S&P Building Products Index are based on our fiscal year.

**Comparison of Five-Year Cumulative Return for Insteel Industries, Inc.,
the Russell 2000 Index and the S&P Building Products Index**

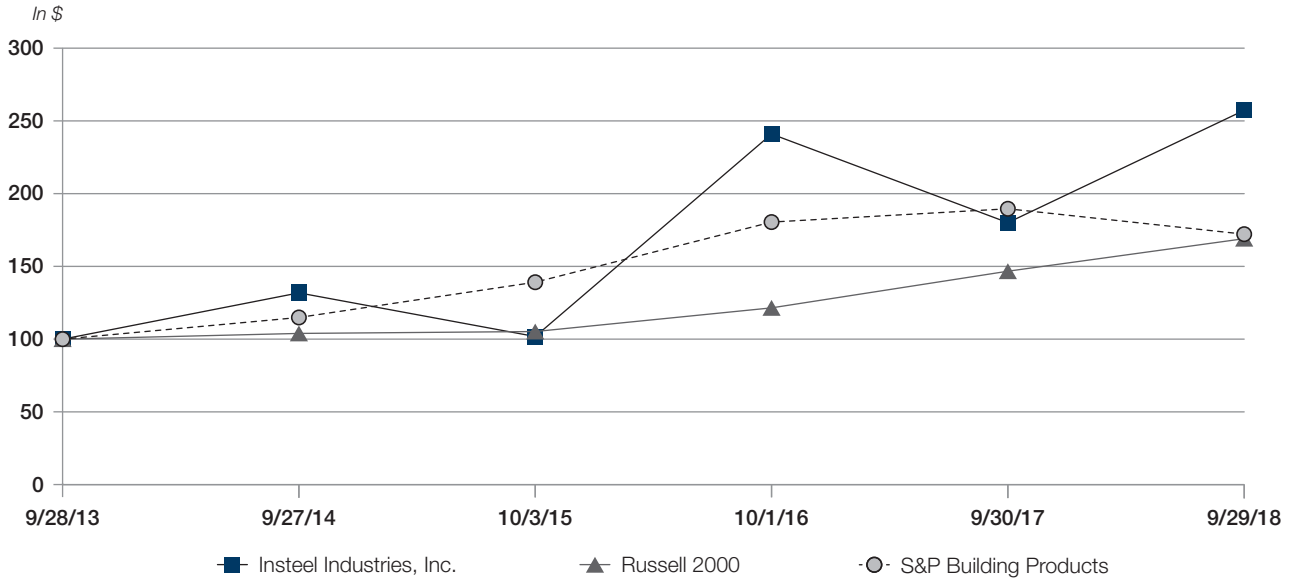

	Fiscal Year Ended					
	9/28/13	9/27/14	10/3/15	10/1/16	9/30/17	9/29/18
Insteel Industries, Inc.	\$ 100.00	\$ 131.84	\$ 101.83	\$ 241.02	\$ 180.10	\$ 257.32
Russell 2000	100.00	103.93	105.23	121.50	146.70	169.06
S&P Building Products	100.00	114.90	139.13	180.47	189.61	172.16

Issuer Purchases of Equity Securities

Information regarding our share repurchase authorization is discussed in Note 18 to our consolidated financial statements and incorporated herein by reference.

Rights Agreement

Information regarding our Rights Agreement is discussed in Note 16 to our consolidated financial statements and incorporated herein by reference.

Item 6 Selected Financial Data

Financial Highlights

<i>(In thousands, except per share amounts)</i>	Year Ended				
	(52 weeks) September 29, 2018	(52 weeks) September 30, 2017	(52 weeks) October 1, 2016	(53 weeks) October 3, 2015	(52 weeks) September 27, 2014
Net sales	\$ 453,217	\$ 388,871	\$ 418,547	\$ 447,504	\$ 408,978
Net earnings	36,266	22,548	37,245	21,710	16,641
Net earnings per share (basic)	1.90	1.19	1.99	1.18	0.91
Net earnings per share (diluted)	1.88	1.17	1.95	1.15	0.89
Cash dividends declared	1.12	1.37	1.12	0.12	0.12
Total assets	329,534	283,073	292,892	260,239	256,795
Total debt	—	—	—	—	—
Shareholders' equity	241,665	223,376	224,566	200,215	178,883

Our August 15, 2014 acquisition of substantially all the assets associated with the PC strand business of American Spring Wire Corporation (the "ASW Acquisition") may materially affect the comparability of the information reflected in the selected financial data presented in this Item 6.

Item 7 Management's Discussion and Analysis of Financial Condition and Results of Operations

The matters discussed in this section include forward-looking statements that are subject to numerous risks. You should carefully read the "Cautionary Note Regarding Forward-Looking Statements" and "Risk Factors" in this Form 10-K.

Overview

Our operations are entirely focused on the manufacture and marketing of concrete reinforcing products for the concrete construction industry. Our business strategy is focused on: (1) achieving leadership positions in our markets; (2) operating

as the lowest cost producer in our industry; and (3) pursuing growth opportunities within our core businesses that further our penetration of the markets we currently serve or expand our footprint.

Critical Accounting Policies

Our consolidated financial statements have been prepared in accordance with accounting principles generally accepted in the United States ("GAAP"). Our discussion and analysis of our financial condition and results of operations are based on these consolidated financial statements. The preparation of our consolidated financial statements requires the application of these accounting principles in addition to certain estimates and judgments based on current available information, actuarial estimates, historical results and other assumptions believed to be reasonable. Actual results could differ from these estimates.

The following critical accounting policies are both important to the depiction of our financial condition and results of operations and require judgments, assumptions and estimates.

Revenue recognition

We recognize revenue from product sales when products are shipped and risk of loss and title has passed to the customer. Sales taxes collected from customers are excluded from revenues and recorded on a net basis.

Concentration of credit risk

Financial instruments that subject us to concentrations of credit risk consist principally of cash and cash equivalents and trade accounts receivable. Our cash is concentrated primarily at one financial institution, which at times exceeds federally insured limits. We are exposed to credit risk in the event of default by institutions in which our cash and cash equivalents are held and by customers to the extent of the amounts recorded for accounts receivable on the balance sheet. We invest excess cash primarily in money market funds, which are highly liquid securities that bear minimal risk.

Most of our accounts receivable are due from customers that are located in the U.S. and are generally not secured by collateral depending upon the creditworthiness of the account. We provide an allowance for doubtful accounts based upon our assessment of the credit risk of specific customers, historical trends and other information. There is no disproportionate concentration of credit risk.

Allowance for doubtful accounts

We maintain allowances for doubtful accounts for estimated losses resulting from the potential inability of our customers to make required payments on outstanding balances owed to us. Significant management judgments and estimates are used in establishing the allowances. These judgments and estimates consider such factors as the financial position, cash flows and payment history of our customers as well as current and expected business conditions. It is reasonably likely that actual collections will differ from our estimates, which may result in increases or decreases in the allowances. Adjustments to the allowances may also be required if there are significant changes in the financial condition of our customers.

Inventory valuation

We periodically evaluate the carrying value of our inventory. This evaluation includes assessing the adequacy of allowances for losses in the normal course of operations, providing for excess and obsolete inventory, and ensuring that inventory is valued at the lower of cost and estimated net realizable value. Our evaluation considers such factors as the cost of inventory, future demand, our historical experience and market conditions. In assessing the realization of inventory values, we are required to make judgments and estimates regarding future market conditions. Because of the subjective nature of these judgments and estimates, it is reasonably likely that actual outcomes will differ from our estimates. Adjustments to these reserves may be required if actual market conditions are substantially different than the assumptions underlying our estimates.

Long-lived assets

We review long-lived assets, which consist principally of property, plant and equipment and finite-lived intangibles, for impairment whenever events or changes in circumstances indicate that the carrying value of the asset may not be fully recoverable. Recoverability of long-lived assets to be held and

used is measured based on the future net undiscounted cash flows expected to be generated by the related asset or asset group. If it is determined that an impairment loss has been incurred, the impairment loss is recognized in the period in which it is incurred and is calculated based on the difference between the carrying value and the present value of estimated future net cash flows or comparable market values. Assets to be disposed of by sale are recorded at the lower of carrying value or fair value less selling cost when we have committed to a disposal plan, and are reported separately as assets held for sale on our balance sheet. Unforeseen events and changes in circumstances and market conditions could negatively affect the value of assets and result in an impairment charge.

Goodwill

Goodwill is tested annually for impairment and whenever events or circumstances change that would make it more likely than not that an impairment may have occurred. We perform our annual impairment analysis as of the first day of the fourth quarter each fiscal year, which involves comparing the current estimated fair value of the reporting unit to its recorded value, including goodwill.

We perform a qualitative assessment to determine whether it is more likely than not that the fair value of the reporting unit is less than its carrying amount. It may be necessary to perform a quantitative analysis where a discounted cash flow model is used to determine the current estimated fair value of the reporting unit. Key assumptions used to determine the fair value of the reporting unit as part of our annual testing (and any required interim testing) include: (a) expected cash flows for the five-year period following the testing date; (b) an estimated terminal value using a terminal year growth rate based on the growth prospects of the reporting unit; (c) a discount rate based on our estimated after-tax weighted average cost of capital; and (d) a probability-weighted scenario approach by which varying cash flows are assigned to alternative scenarios based on their likelihood of occurrence. In developing these assumptions, we consider historical and anticipated future results, general economic and market conditions, the impact of planned business and operational strategies and all available information at the time the fair value of the reporting unit is estimated.

We monitor our operating results throughout the year to determine if events or changes in circumstances warrant any interim impairment testing. Otherwise, goodwill will be subject to the required annual impairment test during our fourth quarter. Changes in the judgments and estimates underlying our analysis of goodwill for possible impairment, including the expected future operating cash flows and discount rate, could reduce our estimated fair value in the future and result in an impairment of goodwill. There was no goodwill impairment loss recognized in fiscal 2018.

Self-insurance

We are self-insured for certain losses relating to medical and workers' compensation claims. Self-insurance claims filed and claims incurred but not reported are accrued based upon our estimates of the discounted ultimate cost for uninsured claims

incurred using actuarial assumptions followed by the insurance industry and historical experience. These estimates are subject to a high degree of variability based upon future inflation rates, litigation trends, changes in benefit levels and claim settlement patterns. Because of uncertainties related to these factors as well as the possibility of changes in the underlying facts and circumstances, future adjustments to these reserves may be required.

Litigation

We are involved in claims, lawsuits and other proceedings, which arise in the ordinary course of business. The eventual outcome of such matters and the potential losses that we may ultimately incur are subject to a high degree of uncertainty. We record expenses for litigation when it is probable that a liability has been incurred and the amount of the loss can be reasonably estimated. We estimate the probability of such losses based on the advice of legal counsel, the outcome of similar litigation, the status of the lawsuits and other factors. Due to the numerous factors that enter into these judgments and assumptions, it is reasonably likely that actual outcomes will differ from our estimates. We monitor our potential exposure to these contingencies on a regular basis and may adjust our estimates as additional information becomes available or as there are significant developments.

Stock-based compensation

We account for stock-based compensation arrangements, including stock option grants and restricted stock units, in accordance with the provisions of ASC Topic 718, Compensation - Stock Compensation. Under these provisions, compensation cost is recognized based on the fair value of equity awards on the date of grant and amortized on a straight-line basis over the vesting period. We use the Monte Carlo valuation model to determine the fair value of stock options at the date of grant, which requires us to make assumptions for the expected term, volatility, dividend yield, risk-free interest rate and forfeiture rates. These assumptions are based on historical information and judgment regarding market factors and trends. If actual results differ from our assumptions and judgments used in estimating these factors, future adjustments to these estimates may be required.

Assumptions for employee benefit plan

We account for our supplemental employee retirement plans (each, a "SERP") in accordance with ASC Topic 715, Compensation - Retirement Benefits. Under the provisions of ASC Topic 715, we recognize net periodic pension cost and value liabilities based on certain actuarial assumptions, principally the assumed discount rate.

Recent Accounting Pronouncements

The nature and impact of recent accounting pronouncements is discussed in Note 3 to our consolidated financial statements and incorporated herein by reference.

The discount rate we utilize for determining net periodic pension cost and the related benefit obligation for the SERPs is based, in part, on current interest rates earned on long-term bonds that receive one of the two highest ratings assigned by recognized rating agencies. Our discount rate assumptions are adjusted as of each valuation date to reflect current interest rates on such long-term bonds. The discount rate is used to determine the actuarial present value of the benefit obligations as of the valuation date as well as the interest component of the net periodic pension cost for the following year. The discount rate for the SERPs was 4.00% for fiscal 2018 and 3.75% for fiscal years 2017 and 2016.

The assumed discount rate is reevaluated annually. Changes in this assumption can result in the recognition of a materially different pension cost over different periods and a materially different liability amount in our consolidated financial statements. A reduction in the assumed discount rate generally results in an actuarial loss, as the actuarially-determined present value of estimated future benefit payments will increase. Conversely, an increase in the assumed discount rate generally results in an actuarial gain. However, any actuarial gains generated in future periods reduce the negative amortization effect of any cumulative unamortized actuarial losses, while any actuarial losses generated in future periods reduce the favorable amortization effect of any cumulative unamortized actuarial gains.

The projected benefit obligations and net periodic pension cost for the SERPs are based in part on expected increases in future compensation levels. Our assumption for the expected increase in future compensation levels is based upon our average historical experience and our intentions regarding future compensation increases, which generally approximates average long-term inflation rates.

We currently expect net periodic pension cost for fiscal 2019 to be \$821,000 for the SERPs. Cash contributions to the SERPs during fiscal 2019 are expected to be \$325,000.

A 0.25% decrease in the assumed discount rate for our SERPs would have increased our projected and accumulated benefit obligations as of September 29, 2018 by approximately \$281,000 and \$228,000, respectively, and our expected net periodic pension cost for fiscal 2019 by approximately \$33,000.

See Note 10 to our consolidated financial statements for the related accounting and disclosures surrounding our terminated pension plan, the Insteel Wire Products Company Retirement Income Plan for Hourly Employees, Wilmington, Delaware (the "Delaware Plan").

Results of Operations

STATEMENTS OF OPERATIONS – SELECTED DATA

<i>(Dollars in thousands)</i>	Year Ended					
	September 29, 2018	Change	September 30, 2017	Change	October 1, 2016	
Net sales	\$ 453,217	16.5%	\$ 388,871	(7.1%)	\$ 418,547	
Gross profit	70,807	18.4%	59,781	(29.8%)	85,188	
<i>Percentage of net sales</i>	15.6%		15.4%		20.4%	
Selling, general and administrative expense	\$ 28,304	11.0%	\$ 25,508	(2.2%)	\$ 26,069	
<i>Percentage of net sales</i>	6.2%		6.6%		6.2%	
Pension plan settlement loss	\$ —	—	\$ —	(100.0%)	\$ 2,539	
Restructuring charges, net	—	(100.0%)	164	42.6%	115	
Other expense, net	274	417.0%	53	(71.0%)	183	
Interest expense	114	(16.2%)	136	(13.9%)	158	
Interest income	(515)	107.7%	(248)	49.4%	(166)	
Effective income tax rate	14.9%		34.0%		33.8%	
Net earnings	\$ 36,266	60.8%	\$ 22,548	(39.5%)	\$ 37,245	

2018 Compared with 2017

Net Sales

Net sales increased 16.5% to \$453.2 million in 2018 from \$388.9 million in 2017, reflecting a 4.6% increase in shipments and an 11.5% increase in average selling prices. The increase in shipments was primarily due to improved market conditions and strengthening demand for our products relative to the prior year. The increase in average selling prices was driven by price increases that were implemented in the current year to recover the escalation in raw material costs.

Gross Profit

Gross profit increased 18.4% to \$70.8 million, or 15.6% of net sales, in 2018 from \$59.8 million, or 15.4% of net sales, in 2017 primarily due to higher spreads between average selling prices and raw material costs (\$6.2 million), higher shipments (\$2.8 million) and lower manufacturing costs (\$1.1 million). The increase in spreads was driven by higher average selling prices (\$46.2 million) partially offset by higher raw material costs (\$38.7 million) and freight expense (\$1.3 million).

Selling, General and Administrative Expense

Selling, general and administrative expense ("SG&A expense") increased 11.0% to \$28.3 million, or 6.2% of net sales, in 2018 from \$25.5 million, or 6.6% of net sales, in 2017 primarily due to higher compensation (\$1.7 million) and employee benefit costs (\$566,000) partially offset by a smaller increase in the cash surrender value of life insurance policies (\$259,000). The increase in compensation expense was largely driven by additional staffing to support the growth of our ESM product line and higher incentive plan expense due to our improved financial results. The increase in employee benefit costs was primarily related to higher employee health insurance costs. The cash surrender value of life insurance policies

increased \$553,000 in 2018 compared with \$812,000 in the prior year due to the changes in the value of the underlying investments.

Restructuring Charges, Net

Net restructuring charges of \$164,000 were incurred in 2017 for equipment relocation costs related to the consolidation of our PC strand facilities.

Other Expense, Net

Other expense for 2018 was \$274,000 compared with \$53,000 in 2017 primarily due to losses on the disposition of property, plant and equipment.

Income Taxes

Our effective income tax rate for 2018 decreased to 14.9% from 34.0% in 2017. The effective rate for 2018 reflects a \$3.3 million gain on the remeasurement of deferred tax assets and liabilities related to the lower corporate tax rate enacted under the Tax Cuts and Jobs Act in December 2017. Excluding the deferred tax gain, our effective rate decreased to 22.7% from 34.0% in the prior year reflecting the reduction in the federal statutory rate to 21% from 35% for three quarters of fiscal 2018.

Net Earnings

Net earnings increased to \$36.3 million (\$1.88 per diluted share) in 2018 from \$22.5 million (\$1.17 per diluted share) in 2017 primarily due to the increase in gross profit together with the deferred tax gain and reduction in our effective tax rate related to the enactment of the Tax Cuts and Jobs Act, partially offset by higher SG&A expense.

2017 Compared with 2016

Net Sales

Net sales decreased 7.1% to \$388.9 million in 2017 from \$418.5 million in 2016 due to lower shipments as average selling prices were essentially unchanged. Shipments in 2017 were unfavorably impacted by adverse weather conditions during the second half of the year including the effect from hurricanes Harvey and Irma on our Texas and Florida facilities together with a reduction in new project activity and competitive pricing pressures.

Gross Profit

Gross profit decreased 29.8% to \$59.8 million, or 15.4% of net sales, in 2017 from \$85.2 million, or 20.4% of net sales, in 2016. The year-over-year decrease was primarily due to lower spreads between average selling prices and raw material costs (\$16.8 million), the decrease in shipments (\$6.4 million) and higher manufacturing costs (\$3.4 million). The decrease in spreads was driven by higher raw material costs (\$16.2 million) and freight expense (\$0.7 million) partially offset by higher average selling prices (\$0.1 million).

Selling, General and Administrative Expense

SG&A expense decreased 2.2% to \$25.5 million, or 6.6% of net sales, in 2017 from \$26.1 million, or 6.2% of net sales, in 2016 primarily due to lower compensation expense (\$762,000) together with the relative year-over-year change in the cash surrender value of life insurance policies (\$332,000), which was partially offset by higher bad debt (\$186,000), travel (\$163,000) and employee benefit expense (\$160,000). The decrease in compensation expense was largely driven by lower incentive plan expense based on our weaker results in 2017. The cash surrender value of life insurance policies increased \$812,000 in 2017 compared with \$480,000 in 2016 due to the changes in the value of the underlying investments. The increase in bad debt expense was

due to an adjustment in 2016 that reduced the allowance for doubtful accounts based on our favorable collections experience. The increase in employee benefit costs was primarily due to higher employee supplemental retirement plan expense.

Pension Plan Settlement Loss

A pension plan settlement loss of \$2.5 million was incurred in 2016 related to the termination of the Delaware Plan.

Restructuring Charges, Net

Net restructuring charges of \$164,000 were incurred in 2017 for equipment relocation costs related to the consolidation of our PC strand facilities. Net restructuring charges of \$115,000 were incurred in 2016, which included equipment relocation costs (\$186,000), facility closure costs (\$89,000) and impairment charges related to the decommissioning of equipment (\$20,000) partially offset by a gain on the sale of equipment previously associated with the Newnan, Georgia PC strand facility (\$180,000).

Income Taxes

Our effective income tax rate for 2017 increased slightly to 34.0% from 33.8% in 2016 due to changes in permanent book versus tax differences.

Net Earnings

Net earnings decreased to \$22.5 million (\$1.17 per diluted share) in 2017 from \$37.2 million (\$1.95 per diluted share) in 2016 primarily due to the decrease in gross profit partially offset by lower SG&A expense and the pension plan settlement loss incurred in 2016.

Liquidity and Capital Resources

SELECTED FINANCIAL DATA

<i>(Dollars in thousands)</i>	Year Ended		
	September 29, 2018	September 30, 2017	October 1, 2016
Net cash provided by operating activities	\$ 53,969	\$ 20,840	\$ 56,253
Net cash used for investing activities	(21,939)	(20,880)	(12,972)
Net cash used for financing activities	(20,194)	(26,728)	(17,666)
Cash and cash equivalents	43,941	32,105	58,873
Net working capital	123,489	117,873	126,704
Total debt	—	—	—
<i>Percentage of total capital</i>	—	—	—
Shareholders' equity	\$ 241,665	\$ 223,376	\$ 224,566
<i>Percentage of total capital</i>	100%	100%	100%
Total capital (total debt + shareholders' equity)	\$ 241,665	\$ 223,376	\$ 224,566

Operating Activities

Operating activities provided \$54.0 million of cash in 2018 primarily from net earnings adjusted for non-cash items and a reduction in the net working capital components of accounts receivable, inventories and accounts payable and accrued expenses. Net working capital provided \$4.7 million of cash due to a \$28.2 million increase in accounts payable and accrued expenses partially offset by a \$12.3 million increase in inventories and an \$11.2 million increase in accounts receivable. The increase in accounts payable and accrued expenses was primarily related to higher raw material purchases near the end of the period and, to a lesser extent, increases in accrued salaries, wages and related expenses. The increases in inventories and accounts receivable were due to the escalation in raw material costs and average selling prices during 2018.

Operating activities provided \$20.8 million of cash in 2017 primarily from net earnings adjusted for non-cash items partially offset by an increase in the net working capital components of accounts receivable, inventories and accounts payable and accrued expenses. Net working capital used \$15.5 million of cash due to an \$11.9 million decrease in accounts payable and accrued expenses and a \$10.7 million increase in inventories partially offset by a \$7.1 million decrease in accounts receivable. The decrease in accounts payable and accrued expenses was primarily related to lower raw material purchases near the end of

the period along with a decrease in accrued salaries, wages and related expenses. The increase in inventories was due to higher raw material costs and, to a lesser extent, quantities on-hand. The decrease in accounts receivable was primarily due to the lower sales in 2017.

Operating activities provided \$56.3 million of cash in 2016 primarily from net earnings adjusted for non-cash items and a reduction in the net working capital components of accounts receivable, inventories and accounts payable and accrued expenses. Net working capital provided \$3.2 million of cash due to a \$9.0 million increase in accounts payable and accrued expenses partially offset by a \$5.2 million increase in inventories and a \$0.6 million increase in accounts receivable. The increases in accounts payable and accrued expenses and inventories were largely related to higher raw material purchases near the end of 2016. The increase in accounts receivable was primarily due to an increase in days sales outstanding partially offset by lower average selling prices.

We may elect to adjust our operating activities as there are changes in the conditions in our construction end-markets, which could materially impact our cash requirements. While a downturn in the level of construction activity affects sales to our customers, it generally reduces our working capital requirements.

Investing Activities

Investing activities used \$21.9 million of cash in 2018 primarily due to \$18.4 million of capital expenditures and \$3.3 million for the acquisition of a business. The capital expenditures were largely related to additional investments in ESM manufacturing capabilities, the purchase of the leased Houston facility and further upgrades of production technology and information systems. Investing activities used \$20.9 million of cash in 2017 primarily due to \$20.6 million of capital expenditures largely related

to the expansion of the Houston, Texas PC strand facility and the addition of a new ESM production line at the St. Joseph, Missouri facility. Investing activities used \$13.0 million of cash in 2016 primarily due to capital expenditures largely related to the expansion of the Houston facility. Our investing activities are largely discretionary, providing us with the ability to significantly curtail outlays should future business conditions warrant that such actions be taken.

Financing Activities

Financing activities used \$20.1 million of cash in 2018, \$26.7 million in 2017 and \$17.7 million in 2016. In 2018, \$21.3 million of cash was used for dividend payments (including a special cash dividend of \$19.0 million, or \$1.00 per share, and regular cash dividends totaling \$2.3 million), which was partially offset by \$2.1 million of proceeds from the exercise of stock options. In 2017, \$26.0 million of cash was used for dividend

payments (including a special cash dividend of \$23.7 million, or \$1.25 per share, and regular cash dividends totaling \$2.3 million). In 2016, \$20.9 million of cash was used for dividend payments (including a special cash dividend of \$18.6 million, or \$1.00 per share, and regular cash dividends totaling \$2.3 million), which was partially offset by \$5.1 million of proceeds from the exercise of stock options.

Cash Management

Our cash is principally concentrated at one financial institution, which at times exceeds federally insured limits. We invest excess cash primarily in money market funds, which are highly liquid securities that bear minimal risk.

Credit Facility

We have a \$100.0 million revolving credit facility (the "Credit Facility") that is used to supplement our operating cash flow and fund our working capital, capital expenditure, general corporate and growth requirements. In May 2015, we amended the Credit Facility to, among other changes, extend its maturity date from June 2, 2016 to May 13, 2020. Advances under the Credit Facility are limited to the lesser of the revolving loan commitment amount (currently \$100.0 million) or a borrowing base amount that is calculated based upon a percentage of eligible receivables and inventories. As of September 29, 2018, no borrowings were outstanding on the Credit Facility, \$98.2 million of borrowing capacity was available and outstanding letters of credit totaled \$1.8 million (see Note 7 to the consolidated financial statements). As of September 30, 2017, there were no borrowings outstanding on the Credit Facility.

We believe that, in the absence of significant unanticipated cash demands, cash and cash equivalents, cash generated by operating activities and the borrowing availability provided under the Credit Facility will be sufficient to satisfy our expected

requirements for working capital, capital expenditures, dividends and share repurchases, if any. We also expect to have access to the amounts available under our Credit Facility as required. However, should we experience future reductions in our operating cash flows due to weakening conditions in our construction end-markets and reduced demand from our customers, we may need to curtail capital and operating expenditures, delay or restrict share repurchases, cease dividend payments and/or realign our working capital requirements.

Should we determine, at any time, that we require additional short-term liquidity, we would evaluate the alternative sources of financing that were potentially available to provide such funding. There can be no assurance that any such financing, if pursued, would be obtained, or if obtained, would be adequate or on terms acceptable to us. However, we believe that our strong balance sheet, flexible capital structure and borrowing capacity available to us under our Credit Facility position us to meet our anticipated liquidity requirements for the foreseeable future.

Impact of Inflation

We are subject to inflationary risks arising from fluctuations in the market prices for our primary raw material, hot-rolled carbon steel wire rod, and, to a much lesser extent, freight, energy and other consumables that are used in our manufacturing processes. We have generally been able to adjust our selling prices to pass through increases in these costs or offset them through various cost reduction and productivity improvement initiatives. However, our ability to raise our selling prices depends on market conditions and competitive dynamics, and there may be periods during which we are unable to fully recover increases in our costs.

During 2018, we were successful in implementing price increases sufficient to recover the escalation in our raw material costs that occurred over the course of the year. In 2017, we were unable to fully recover the increase in our raw material costs due to the weakening in demand and competitive pricing pressures. During 2016, our raw material costs rose over most of the period, which we were generally able to recover through price increases. The timing and magnitude of any future increases in raw material costs and the impact on selling prices for our products is uncertain at this time.

Off-Balance Sheet Arrangements

We do not have any material transactions, arrangements, obligations (including contingent obligations), or other relationships with unconsolidated entities or other persons, as defined by Item 303(a)(4) of Regulation S-K of the SEC, that have or are

reasonably likely to have a material current or future impact on our financial condition, results of operations, liquidity, capital expenditures, capital resources or significant components of revenues or expenses.

Contractual Obligations

Our contractual obligations and commitments at September 29, 2018 are as follows:

PAYMENTS DUE BY PERIOD

(In thousands)

Contractual obligations:	Total	Less Than 1 Year	1 – 3 Years	3 – 5 Years	More Than 5 Years
Raw material purchase commitments ⁽¹⁾	\$ 75,116	\$ 75,116	\$ —	\$ —	\$ —
Supplemental employee retirement plan obligations	19,904	325	523	1,107	17,949
Operating leases	1,799	1,034	728	37	—
Trade letters of credit	1,789	1,789	—	—	—
Commitment fee on unused portion of credit facility	615	368	247	—	—
Other unconditional purchase obligations ⁽²⁾	9,565	9,565	—	—	—
TOTAL	\$ 108,788	\$ 88,197	\$ 1,498	\$ 1,144	\$ 17,949

(1) Non-cancelable purchase commitments for raw materials.

(2) Contractual commitments for capital expenditures.

Outlook

Looking ahead to 2019, we expect our financial results will be favorably impacted by continued growth in our construction end-markets. The infrastructure-related portion of our business should benefit from increased federal funding through the FAST Act and supplementary measures together with higher state and local spending in many of our markets supported by various initiatives such as fuel tax increases, bond issuances and other ballot measures. The leading indicators and industry forecasts for nonresidential construction remain positive, and the housing recovery is expected to continue driven by favorable employment and demographic trends.

Business conditions are likely to remain challenging, however, in view of the escalation in our raw material costs resulting from the Administration's Section 232 imported steel tariff program. Considering that the tariffs do not apply to imports of downstream products such as welded wire reinforcement and PC strand, we expect a surge in low-priced import competition that results in market share erosion and margin compression for domestic producers. We are engaged with the Administration and Congress

to arrive at a solution that addresses the unsustainable competitive environment resulting from the tariff program.

We will continue to maintain our focus on the operational fundamentals of our business: closely managing and controlling our expenses; aligning our production schedules with demand in a proactive manner as there are changes in market conditions to minimize our cash operating costs; and pursuing further improvements in the productivity and effectiveness of all of our manufacturing, selling and administrative activities. We also expect gradually increasing contributions from the substantial investments we have made in our facilities in the form of reduced operating costs and additional capacity to support future growth. In addition, we will continue to pursue further acquisitions in our existing businesses that expand our penetration of markets we currently serve or expand our footprint.

The statements contained in this section are forward-looking statements. See "Cautionary Note Regarding Forward-Looking Statements" and "Risk Factors".

Item 7A Quantitative and Qualitative Disclosures About Market Risk

Our cash flows and earnings are subject to fluctuations resulting from changes in commodity prices, interest rates and foreign exchange rates. We manage our exposure to these market risks through internally established policies and procedures and, when appropriate, through the use of derivative financial instruments.

We do not use financial instruments for trading purposes and are not a party to any leveraged derivatives. We monitor our underlying market risk exposures on an ongoing basis and believe we can modify or adapt our hedging strategies as necessary.

Commodity Prices

We are subject to significant fluctuations in the cost and availability of our primary raw material, hot-rolled carbon steel wire rod, which we purchase from both domestic and foreign suppliers. We negotiate quantities and pricing for both domestic and foreign wire rod purchases for varying periods (most recently monthly for domestic suppliers), depending upon market conditions, to manage our exposure to price fluctuations and to ensure adequate availability of material consistent with our requirements. We do not use derivative commodity instruments to hedge our exposure to changes in prices as such instruments are not currently available for wire rod. Our ability to acquire wire rod from foreign sources on favorable terms is impacted by fluctuations in foreign currency exchange rates, foreign taxes, duties, tariffs, quotas and other

trade actions. Although changes in our wire rod costs and selling prices tend to be correlated, in weaker market environments, we may be unable to fully recover increased rod costs, which would reduce our earnings and cash flows. Additionally, when raw material costs decline, our financial results may be negatively impacted if the selling prices for our products decrease to an even greater extent and if we are consuming higher cost material from inventory. Based on our 2018 shipments and average wire rod cost reflected in cost of sales, a 10% increase in the price of wire rod would have resulted in a \$26.6 million decrease in our annual pre-tax earnings (assuming there was not a corresponding change in our selling prices).

Interest Rates

Although we did not have any balances outstanding on our Credit Facility as of September 29, 2018, future borrowings under the facility are subject to a variable rate of interest and are sensitive to changes in interest rates.

Foreign Exchange Exposure

We have not typically hedged foreign currency exposures related to transactions denominated in currencies other than U.S. dollars, as such transactions have not been material historically. We will occasionally hedge firm commitments for certain equipment purchases that are denominated in foreign currencies. The decision to hedge any such transactions is made

by us on a case-by-case basis. There were no forward contracts outstanding as of September 29, 2018. During 2018, a 10% increase or decrease in the value of the U.S. dollar relative to foreign currencies to which we are typically exposed would not have had a material impact on our financial position, results of operations or cash flows.

Item 8 Financial Statements and Supplementary Data

(a) Financial Statements

Consolidated Statements of Operations for the years ended September 29, 2018, September 30, 2017 and October 1, 2016	24
Consolidated Statements of Comprehensive Income for the years ended September 29, 2018, September 30, 2017 and October 1, 2016	25
Consolidated Balance Sheets as of September 29, 2018 and September 30, 2017	26
Consolidated Statements of Shareholders' Equity for the years ended September 29, 2018, September 30, 2017 and October 1, 2016	27
Consolidated Statements of Cash Flows for the years ended September 29, 2018, September 30, 2017 and October 1, 2016	28
Notes to Consolidated Financial Statements	29
Report of Independent Registered Public Accounting Firm – Consolidated Financial Statements	45
Schedule II – Valuation and Qualifying Accounts for the years ended September 29, 2018, September 30, 2017 and October 1, 2016	46

(b) Supplementary Data

Selected quarterly financial data for 2018 and 2017 is as follows:

FINANCIAL INFORMATION BY QUARTER (UNAUDITED)

<i>(In thousands, except per share amounts)</i>	Quarter Ended			
	December 30	March 31	June 30	September 29
2018				
Operating results:				
Net sales	\$ 97,741	\$ 107,417	\$ 126,688	\$ 121,371
Gross profit	11,661	15,416	24,186	19,544
Net earnings	8,111	5,879	12,868	9,408
Net earnings per share:				
Basic	0.43	0.31	0.67	0.49
Diluted	0.42	0.31	0.67	0.49

	Quarter Ended			
	December 31	April 1	July 1	September 30
2017				
Operating results:				
Net sales	\$ 93,888	\$ 101,159	\$ 96,938	\$ 96,886
Gross profit	13,010	18,294	16,676	11,801
Net earnings	4,460	7,420	6,869	3,799
Net earnings per share:				
Basic	0.24	0.39	0.36	0.20
Diluted	0.23	0.39	0.36	0.20

Insteel Industries, Inc. and Subsidiaries

Consolidated Statements of Operations

	Year Ended		
	September 29, 2018	September 30, 2017	October 1, 2016
<i>(In thousands, except per share amounts)</i>			
Net sales	\$ 453,217	\$ 388,871	\$ 418,547
Cost of sales	382,410	329,090	333,359
Gross profit	70,807	59,781	85,188
Selling, general and administrative expense	28,304	25,508	26,069
Pension plan settlement loss	—	—	2,539
Restructuring charges, net	—	164	115
Other expense, net	274	53	183
Interest expense	114	136	158
Interest income	(515)	(248)	(166)
Earnings before income taxes	42,630	34,168	56,290
Income taxes	6,364	11,620	19,045
NET EARNINGS	\$ 36,266	\$ 22,548	\$ 37,245
Net earnings per share:			
Basic	\$ 1.90	\$ 1.19	\$ 1.99
Diluted	1.88	1.17	1.95
Cash dividends declared	1.12	1.37	1.12
Weighted average shares outstanding:			
Basic	19,079	19,011	18,754
Diluted	19,277	19,217	19,055

See accompanying notes to consolidated financial statements.

Insteel Industries, Inc. and Subsidiaries

Consolidated Statements of Comprehensive Income

(In thousands)	Year Ended		
	September 29, 2018	September 30, 2017	October 1, 2016
Net earnings	\$ 36,266	\$ 22,548	\$ 37,245
Pension plan settlement, net of income taxes of (\$733)	—	—	1,197
Adjustment to defined benefit plan liability, net of income taxes of (\$44), (\$127) and \$363	139	208	(592)
Other comprehensive income	139	208	605
COMPREHENSIVE INCOME	\$ 36,405	\$ 22,756	\$ 37,850

See accompanying notes to consolidated financial statements.

Insteel Industries, Inc. and Subsidiaries

Consolidated Balance Sheets

(In thousands, except per share amounts)

	September 29, 2018	September 30, 2017
ASSETS:		
Current assets:		
Cash and cash equivalents	\$ 43,941	\$ 32,105
Accounts receivable, net	51,484	40,284
Inventories	94,157	81,853
Other current assets	5,895	5,949
Total current assets	195,477	160,191
Property, plant and equipment, net	106,148	98,670
Intangibles, net	9,703	7,913
Goodwill	8,293	6,965
Other assets	9,913	9,334
TOTAL ASSETS	\$ 329,534	\$ 283,073
LIABILITIES AND SHAREHOLDERS' EQUITY:		
Current liabilities:		
Accounts payable	\$ 60,059	\$ 33,651
Accrued expenses	11,929	8,667
Total current liabilities	71,988	42,318
Other liabilities	15,881	17,379
Commitments and contingencies		
Shareholders' equity:		
Preferred stock, no par value Authorized shares: 1,000 None issued	—	—
Common stock, \$1 stated value Authorized shares: 50,000 Issued and outstanding shares: 2018, 19,223; 2017, 19,041	19,223	19,041
Additional paid-in capital	72,852	69,817
Retained earnings	151,084	135,851
Accumulated other comprehensive loss	(1,494)	(1,333)
Total shareholders' equity	241,665	223,376
TOTAL LIABILITIES AND SHAREHOLDERS' EQUITY	\$ 329,534	\$ 283,073

See accompanying notes to consolidated financial statements.

Insteel Industries, Inc. and Subsidiaries

Consolidated Statements of Shareholders' Equity

(In thousands)	Common Stock		Additional Paid-In Capital	Retained Earnings	Accumulated Other Comprehensive Income (Loss) ⁽¹⁾	Total Shareholders' Equity
	Shares	Amount				
Balance at October 3, 2015	18,466	\$ 18,466	\$ 60,967	\$ 122,928	\$ (2,146)	\$ 200,215
Net earnings				37,245		37,245
Other comprehensive income ⁽¹⁾					605	605
Stock options exercised	463	463	4,602			5,065
Vesting of restricted stock units	47	47	(47)			—
Compensation expense associated with stock-based plans			2,439			2,439
Excess tax benefits from stock-based compensation			1,717			1,717
Restricted stock units and stock options surrendered for withholding taxes payable			(1,861)			(1,861)
Cash dividends declared				(20,859)		(20,859)
Balance at October 1, 2016	18,976	18,976	67,817	139,314	(1,541)	224,566
Net earnings				22,548		22,548
Other comprehensive income ⁽¹⁾					208	208
Stock options exercised	26	26	81			107
Vesting of restricted stock units	39	39	(39)			—
Compensation expense associated with stock-based plans			2,245			2,245
Excess tax benefits from stock-based compensation			537			537
Restricted stock units and stock options surrendered for withholding taxes payable			(824)			(824)
Cash dividends declared				(26,011)		(26,011)
Balance at September 30, 2017	19,041	19,041	69,817	135,851	(1,333)	223,376
Net earnings				36,266		36,266
Other comprehensive income ⁽¹⁾					139	139
Stock options exercised	143	143	1,938			2,081
Vesting of restricted stock units	39	39	(39)			—
Compensation expense associated with stock-based plans			2,078			2,078
Restricted stock units and stock options surrendered for withholding taxes payable			(942)			(942)
Adoption of ASU 2018-02 (Note 3)				300	(300)	—
Cash dividends declared				(21,333)		(21,333)
BALANCE AT SEPTEMBER 29, 2018	19,223	\$19,223	\$ 72,852	\$ 151,084	\$ (1,494)	\$ 241,665

(1) Activity within accumulated other comprehensive income (loss) is reported net of related income taxes: 2016 (\$370), 2017 (\$127) and 2018 (\$44).

See accompanying notes to consolidated financial statements.

Insteel Industries, Inc. and Subsidiaries

Consolidated Statements of Cash Flows

(In thousands)	Year Ended		
	September 29, 2018	September 30, 2017	October 1, 2016
Cash Flows From Operating Activities:			
Net earnings	\$ 36,266	\$ 22,548	\$ 37,245
Adjustments to reconcile net earnings to net cash provided by operating activities:			
Depreciation and amortization	12,818	11,649	11,544
Amortization of capitalized financing costs	65	65	65
Stock-based compensation expense	2,078	2,245	2,439
Deferred income taxes	(2,807)	2,503	536
Pension plan settlement loss, net of cash contributed	—	—	620
Asset impairment charges	—	—	20
Loss on sale and disposition of property, plant and equipment	381	64	61
Increase in cash surrender value of life insurance policies over premiums paid	(553)	(812)	(480)
Net changes in assets and liabilities:			
Accounts receivable, net	(11,200)	7,105	(607)
Inventories	(12,304)	(10,667)	(5,177)
Accounts payable and accrued expenses	28,234	(11,930)	9,009
Other changes	991	(1,930)	978
Total adjustments	17,703	(1,708)	19,008
NET CASH PROVIDED BY OPERATING ACTIVITIES	53,969	20,840	56,253
Cash Flows From Investing Activities:			
Capital expenditures	(18,449)	(20,575)	(12,977)
Proceeds from surrender of life insurance policies	165	100	140
Increase in cash surrender value of life insurance policies	(355)	(405)	(375)
Acquisition of business	(3,300)	—	—
Proceeds from sale of assets held for sale	—	—	180
Proceeds from sale of property, plant and equipment	—	—	60
NET CASH USED FOR INVESTING ACTIVITIES	(21,939)	(20,880)	(12,972)
Cash Flows From Financing Activities:			
Proceeds from long-term debt	372	404	328
Principal payments on long-term debt	(372)	(404)	(328)
Cash dividends paid	(21,333)	(26,011)	(20,859)
Cash received from exercise of stock options	2,081	107	5,065
Payment of employee tax withholdings related to net share transactions	(942)	(824)	(1,861)
Financing costs	—	—	(11)
NET CASH USED FOR FINANCING ACTIVITIES	(20,194)	(26,728)	(17,666)
Net increase (decrease) in cash and cash equivalents	11,836	(26,768)	25,615
Cash and cash equivalents at beginning of period	32,105	58,873	33,258
CASH AND CASH EQUIVALENTS AT END OF PERIOD	\$ 43,941	\$ 32,105	\$ 58,873
Supplemental Disclosures of Cash Flow Information:			
Cash paid during the period for:			
Income taxes, net	\$ 7,777	\$ 9,300	\$ 19,184
Non-cash investing and financing activities:			
Purchases of property, plant and equipment in accounts payable	967	465	1,746
Restricted stock units and stock options surrendered for withholding taxes payable	942	824	1,861

See accompanying notes to consolidated financial statements.

Insteel Industries, Inc. and Subsidiaries

Notes to Consolidated Financial Statements

Years Ended September 29, 2018, September 30, 2017 and October 1, 2016

Note 1 Description of Business

Insteel Industries, Inc. (“we,” “us,” “our,” “Insteel” or “the Company”) is the nation’s largest manufacturer of steel wire reinforcing products for concrete construction applications. Insteel is the parent holding company for two wholly-owned subsidiaries, Insteel Wire Products Company (“IWP”), an operating subsidiary, and Intercontinental Metals Corporation, an inactive subsidiary. We manufacture and market prestressed concrete strand (“PC strand”) and welded wire reinforcement (“WWR”), including engineered structural mesh, concrete pipe reinforcement and standard welded wire reinforcement. Our products are primarily

sold to manufacturers of concrete products and, to a lesser extent, distributors, rebar fabricators and contractors. We sell our products nationwide across the U.S. and, to a much lesser extent, into Canada, Mexico, and Central and South America.

We have evaluated all subsequent events that occurred after the balance sheet date through the time of filing this Annual Report on Form 10-K and concluded there were no events or transactions during this period that required additional recognition or disclosure in our financial statements.

Note 2 Summary of Significant Accounting Policies

Fiscal year

Our fiscal year is the 52 or 53 weeks ending on the Saturday closest to September 30. Fiscal years 2018, 2017 and 2016 were 52-week periods. All references to years relate to fiscal years rather than calendar years.

Principles of consolidation

The consolidated financial statements include the accounts of Insteel and our subsidiaries. All significant intercompany transactions and accounts have been eliminated in consolidation.

Use of estimates

The preparation of financial statements in conformity with accounting principles generally accepted in the United States (“U.S.” and such accounting principles, “GAAP”) requires us to make estimates and assumptions that affect the amounts reported in the financial statements and accompanying notes. There is no assurance that actual results will not differ from these estimates.

Cash equivalents

We consider all highly liquid investments purchased with original maturities of three months or less to be cash equivalents.

Concentration of credit risk

Financial instruments that subject us to concentrations of credit risk consist principally of cash and cash equivalents and trade accounts receivable. Our cash is principally concentrated at one financial institution, which at times exceeds federally insured limits. We are exposed to credit risk in the event of default by institutions

in which our cash and cash equivalents are held and by customers to the extent of the amounts recorded on the balance sheet. We invest excess cash primarily in money market funds, which are highly liquid securities.

The majority of our accounts receivable are due from customers that are located in the U.S. and are generally not secured by collateral depending upon the creditworthiness of the account. We provide an allowance for doubtful accounts based upon our assessment of the credit risk of specific customers, historical trends and other information. We write off accounts receivable when they become uncollectible. There is no disproportionate concentration of credit risk.

Stock-based compensation

We account for stock-based compensation in accordance with the fair value recognition provisions of Financial Accounting Standards Board (“FASB”) Accounting Standards Codification (“ASC”) Topic 718, Compensation – Stock Compensation, which requires stock-based compensation expense to be recognized in net earnings based on the fair value of the award on the date of the grant. We account for forfeitures as they occur. We determine the fair value of stock options issued by using a Monte Carlo valuation model at the grant date, which considers a range of assumptions including the expected term, volatility, dividend yield and risk-free interest rate.

Revenue recognition

We recognize revenue from product sales when products are shipped and risk of loss and title has passed to the customer. Sales taxes collected from customers are excluded from revenues and recorded on a net basis.

Shipping and handling costs

We include all of the outbound freight, shipping and handling costs associated with the shipment of products to customers in cost of sales. Any amounts paid by customers to us for shipping and handling are recorded in net sales on the consolidated statements of operations.

Inventories

Inventories are valued at the lower of weighted average cost (which approximates computation on a first-in, first-out basis) and net realizable value. The valuation of inventory includes the costs for material, labor and manufacturing overhead.

Property, plant and equipment

Property, plant and equipment are recorded at cost or fair market value in the case of the assets acquired through acquisitions, or otherwise at reduced values to the extent there have been asset impairment write-downs. Expenditures for maintenance and repairs are charged directly to expense when incurred, while major improvements are capitalized. Depreciation is computed for financial reporting purposes principally by use of the straight-line method over the following estimated useful lives: machinery and equipment, 3 - 15 years; buildings, 10 - 30 years; and land improvements, 5 - 15 years. Depreciation expense was approximately \$11.6 million in 2018, \$10.5 million in 2017 and \$10.4 million in 2016 and reflected in cost of sales and selling, general and administrative expense ("SG&A expense") in the consolidated statements of operations. Capitalized software is amortized over the shorter of the estimated useful life or 5 years and reflected in SG&A expense in the consolidated statements of operations. No interest costs were capitalized in 2018, 2017 and 2016.

Goodwill

Goodwill is the excess of cost over the fair value of net assets of businesses acquired. Goodwill is not amortized but is tested annually for impairment and whenever events or circumstances change that would make it more likely than not that an impairment may have occurred. We perform our annual impairment analysis as of the first day of the fourth quarter each year. The evaluation of impairment involves comparing the current estimated fair value of the reporting unit to its recorded value, including goodwill. We perform a qualitative assessment to determine whether it is more likely than not that the fair value of the reporting unit is less than its carrying amount. It may be necessary to perform a quantitative analysis where a discounted cash flow model is used to determine the current estimated fair value of the reporting unit. Key assumptions used to determine the fair value of the reporting unit as part of our annual testing (and any required interim testing) include: (a) expected cash flows for the five-year period following the testing date; (b) an estimated terminal value using a terminal year growth rate based on the growth prospects of the reporting unit; (c) a discount rate based on our estimated after-tax weighted average cost of capital; and (d) a probability-weighted scenario

approach by which varying cash flows are assigned to alternative scenarios based on their likelihood of occurrence. In developing these assumptions, we consider historical and anticipated future results, general economic and market conditions, the impact of planned business and operational strategies and all available information at the time the fair value of the reporting unit is estimated. Assumptions in estimating future cash flows are subject to a high degree of judgment and complexity. Changes in assumptions and estimates may affect the fair value of goodwill and could result in impairment charges in future periods. Based on the results of our impairment analysis, no goodwill impairment losses were recognized in the consolidated statements of operations for 2018. Subsequent to the analysis, there have been no events or circumstances that indicate any potential impairment of goodwill.

Other assets

Other assets consist principally of capitalized financing costs related to our revolving credit facility and the cash surrender value of life insurance policies. Capitalized financing costs are amortized using the straight-line method, which approximates the effective interest method over the term of the related credit agreement, and reflected in interest expense in the consolidated statements of operations.

Long-lived assets

Long-lived assets include property, plant and equipment and identifiable intangible assets with definite useful lives. Finite-lived intangible assets are amortized over their estimated useful lives. Our intangible assets consist of customer relationships, developed technology and know-how, non-competition agreements and a trade name, and are being amortized on a straight-line basis over their finite useful lives (see Note 6 to the consolidated financial statements). We assess the impairment of long-lived assets whenever events or changes in circumstances indicate that the carrying value may not be fully recoverable. When we determine that the carrying value of such assets may not be recoverable, we measure recoverability based on the undiscounted cash flows expected to be generated by the related asset or asset group. If it is determined that an impairment loss has occurred, the loss is recognized in the period in which it is incurred and is calculated as the difference between the carrying value and the present value of estimated future net cash flows or comparable market values.

There were no impairment losses in 2018 and 2017. During 2016, we recorded \$20,000 of impairment charges related to long-lived assets resulting from the consolidation of our PC strand operations with the closure of the Newnan, Georgia facility (see Note 4 to the consolidated financial statements).

Fair value of financial instruments

The carrying amounts for cash and cash equivalents, accounts receivable, and accounts payable and accrued expenses approximate fair value because of their short maturities.

Income taxes

Income taxes are based on pretax financial accounting income. Deferred tax assets and liabilities are recognized for the expected tax consequences of temporary differences between the tax bases of assets and liabilities and their reported amounts. We assess the need to establish a valuation allowance against deferred tax assets to the extent we no longer believe it is more likely than not that the tax assets will be fully realized.

Earnings per share

Basic earnings per share (“EPS”) are computed by dividing earnings available to common shareholders by the weighted average number of shares of common stock outstanding during the period. Diluted EPS are computed by dividing earnings available to common shareholders by the weighted average number of shares of common stock and other dilutive equity securities outstanding during the period. Securities that have the effect of increasing EPS are considered to be antidilutive and are not included in the computation of diluted EPS.

Note 3 Recent Accounting Pronouncements

Current Adoptions

In February 2018, the FASB issued Accounting Standards Update (“ASU”) No. 2018-02 “Income Statement - Reporting Comprehensive Income (Topic 220): Reclassification of Certain Tax Effects from Accumulated Other Comprehensive Income.” ASU No. 2018-02 provides for the reclassification of stranded income tax effects resulting from the Tax Cuts and Jobs Act from accumulated other comprehensive income to retained earnings. ASU 2018-02 is effective for interim and annual periods beginning after December 15, 2018, with early adoption permitted. We elected to early adopt ASU 2018-02 during our fourth fiscal quarter. The amount of the stranded income tax effect was determined under the specific identification approach and derived from the deferred tax balance associated with our supplemental employee retirement plan. The adoption of the guidance resulted in the transfer of \$0.3 million from accumulated other comprehensive loss to retained earnings, with no impact to total shareholders’ equity or net earnings.

In March 2016, the FASB issued ASU No. 2016-09, “Compensation - Stock Compensation (Topic 718): Improvements to Employee Share-Based Payment Accounting,” which is intended to simplify the accounting for share-based payment transactions, including the income tax consequences, classification of awards as either equity or liabilities and classification on the statement of cash flows. We adopted this update during our first quarter. ASU No. 2016-09 requires that excess income tax benefits and deficiencies related to share-based payments be recognized within income tax expense as a discrete event in the period in which they occur, rather than within additional paid-in capital on our consolidated balance sheet on a prospective basis. There was no material impact from this provision on income tax expense in the current year. The impact of this provision on our future results of operations is difficult to predict as it will depend in part on the market prices for the shares of our common stock on the dates there are taxable events related to the share-based awards. In connection with another provision within ASU No. 2016-09, we have elected to account for forfeitures of share-based awards as an estimate of the number of awards that are expected to vest, which is consistent with our accounting policy prior to adoption. We also adopted the provisions related to changes on the consolidated statements of cash flows on a retrospective basis. As a result, we no longer classify excess income tax benefits as a

financing activity, which increased net cash provided by operating activities and reduced net cash provided by financing activities by \$0.5 million and \$1.7 million for 2017 and 2016, respectively.

In July 2015, the FASB issued ASU No. 2015-11 “Simplifying the Measurement of Inventory,” which requires that an entity measure inventory at the lower of cost and net realizable value. Net realizable value is the estimated selling price in the ordinary course of business less reasonably predictable costs of completion, disposal and transportation. We adopted ASU No. 2015-11 during our first quarter. The adoption of this update did not have a material effect on our consolidated financial statements.

Future Adoptions

In May 2017, the FASB issued ASU No. 2017-09 “Compensation – Stock Compensation (Topic 718): Scope of Modification Accounting.” ASU No. 2017-09 was issued to clarify and reduce both (i) diversity in practice and (ii) cost and complexity when applying its guidance to changes in the terms and conditions of a share-based payment award. ASU No. 2017-09 will become effective for us in the first quarter of fiscal 2020. We are evaluating the impact that the adoption of this update will have on our consolidated financial statements.

In January 2017, the FASB issued ASU No. 2017-04 “Intangibles—Goodwill and Other (Topic 350): Simplifying the Test for Goodwill Impairment,” which simplifies the accounting for goodwill impairments by eliminating step 2 from the goodwill impairment test. ASU No. 2017-04 will become effective for us in the first quarter of fiscal 2021. Early adoption is permitted. We are evaluating the impact that the adoption of this update will have on our consolidated financial statements.

In August 2016, the FASB issued ASU No. 2016-15 “Statement of Cash Flows Topic 230: Classification of Certain Cash Receipts and Cash Payments.” ASU No. 2016-15 addresses how certain cash receipts and cash payments are presented and classified in the statement of cash flows with the objective of reducing existing differences in the presentation of these items. The amendments in ASU No. 2016-15 are to be adopted retrospectively and will become effective for us in the first quarter of fiscal 2019. We do not expect the adoption of this update will have a material effect on our consolidated financial statements.

In February 2016, the FASB issued ASU No. 2016-02 “Leases,” which will replace the guidance in ASC Topic 840. ASU No. 2016-02 was issued to increase transparency and comparability among organizations by recognizing all lease transactions (with terms in excess of 12 months) on the balance sheet as a lease liability and a right-of-use asset. ASU No. 2016-02 will become effective for us in the first quarter of fiscal 2020. We are evaluating the impact that the adoption of this update will have on our consolidated financial statements.

In May 2014, the FASB issued ASU No. 2014-09 “Revenue from Contracts with Customers,” as subsequently amended, which will supersede nearly all existing revenue recognition guidance under GAAP. ASU No. 2014-09 provides that an entity recognize revenue when it transfers promised goods or services to customers in an amount that reflects the consideration to which

the entity expects to be entitled in exchange for those goods or services. This update also requires additional disclosure about the nature, amount, timing and uncertainty of revenue and cash flows arising from customer contracts, including significant judgments and changes in judgments, and assets recognized from costs incurred to obtain or fulfill a contract. ASU No. 2014-09 allows for either full retrospective or modified retrospective adoption and will become effective for us in the first quarter of fiscal 2019. We have substantially completed our evaluation of the impact this update will have on our consolidated financial statements and plan on using the modified retrospective method upon adoption. We have not identified any material changes in the timing of revenue recognition that will result from the adoption of this guidance, but expect it will have a material impact on the disclosures required in our notes to the consolidated financial statements.

Note 4 Restructuring Charges

In 2014 we purchased substantially all of the assets associated with the PC strand business of American Spring Wire Corporation (“ASW Acquisition”). Subsequent to the ASW Acquisition, in 2014, we incurred employee separation costs for staffing reductions

associated with the acquisition. In February 2015, we elected to consolidate our PC strand operations with the closure of the Newnan, Georgia facility that had been acquired through the ASW Acquisition, which was completed in March 2015.

Following is a summary of the restructuring activities and associated costs that were incurred during 2017 and 2016:

<i>(In thousands)</i>	Asset Impairment Charges	Equipment Relocation Costs	Severance and Other Employee Separation Costs	Facility Closure Costs	Gain on Sale of Property and Equipment	Total
2017						
Liability as of October 1, 2016	\$ —	\$ 31	\$ 239	\$ —	\$ —	\$ 270
Restructuring charges	—	164	—	—	—	164
Cash payments	—	(195)	(239)	—	—	(434)
Non-cash charges	—	—	—	—	—	—
LIABILITY AS OF SEPTEMBER 30, 2017	\$ —	\$ —	\$ —	\$ —	\$ —	\$ —
2016						
Liability as of October 3, 2015	\$ —	\$ —	\$ 735	\$ —	\$ —	\$ 735
Restructuring charges (recoveries)	20	186	—	89	(180)	115
Cash payments	—	(155)	(496)	(89)	—	(740)
Non-cash charges	(20)	—	—	—	180	160
LIABILITY AS OF OCTOBER 1, 2016	\$ —	\$ 31	\$ 239	\$ —	\$ —	\$ 270

Note 5 Fair Value Measurements

Fair value is defined as the price that would be received to sell an asset or paid to transfer a liability in an orderly transaction between market participants at the measurement date. The authoritative guidance for fair value measurements establishes a three-level fair value hierarchy that encourages an entity to maximize the use of observable inputs and minimize the use of unobservable inputs when measuring fair value. The three levels of inputs used to measure fair value are as follows:

Level 1 - Quoted prices in active markets for identical assets or liabilities.

Level 2 - Observable inputs other than quoted prices included in Level 1, such as quoted prices for similar assets and liabilities in active markets.

Level 3 - Unobservable inputs that are supported by little or no market activity and that are significant to the fair value of the assets or liabilities, including certain pricing models, discounted cash flow methodologies and similar techniques that use significant unobservable inputs.

As of September 29, 2018 and September 30, 2017, we held financial assets that are required to be measured at fair value on a recurring basis, which are summarized below:

<i>(In thousands)</i>	Total	Quoted Prices in Active Markets (Level 1)	Observable Inputs (Level 2)
Year ended September 29, 2018:			
Current assets:			
Cash equivalents	\$ 44,257	\$ 44,257	\$ —
Other assets:			
Cash surrender value of life insurance policies	9,769	—	9,769
TOTAL	\$ 54,026	\$ 44,257	\$ 9,769
Year ended September 30, 2017:			
Current assets:			
Cash equivalents	\$ 31,659	\$ 31,659	\$ —
Other assets:			
Cash surrender value of life insurance policies	9,026	—	9,026
TOTAL	\$ 40,685	\$ 31,659	\$ 9,026

Cash equivalents, which include all highly liquid investments with original maturities of three months or less, are classified as Level 1 of the fair value hierarchy. The carrying amount of our cash equivalents, which consist of investments in money market funds, approximates fair value due to their short maturities. Cash surrender value of life insurance policies are classified as Level 2. The fair value of the life insurance policies was determined by the underwriting insurance company's valuation models and

represents the guaranteed value we would receive upon surrender of these policies as of the reporting date.

As of September 29, 2018 and September 30, 2017, we had no nonfinancial assets that are required to be measured at fair value on a nonrecurring basis. The carrying amounts of accounts receivable, accounts payable and accrued expenses approximates fair value due to the short-term maturities of these financial instruments.

Note 6 Intangible Assets

The primary components of our intangible assets and the related accumulated amortization are as follows:

<i>(In thousands)</i>	Weighted- Average Useful Life (Years)	Gross	Accumulated Amortization	Net Book Value
Year ended September 29, 2018:				
Customer relationships	16.9	\$ 9,070	\$ (1,598)	\$ 7,472
Developed technology and know-how	20.0	1,800	(371)	1,429
Non-competition agreements	5.0	3,687	(2,994)	693
Trade name	4.0	140	(31)	109
		\$ 14,697	\$ (4,994)	\$ 9,703
Year ended September 30, 2017:				
Customer relationships	20.0	\$ 6,500	\$ (1,018)	\$ 5,482
Developed technology and know-how	20.0	1,800	(283)	1,517
Non-competition agreements	4.8	3,577	(2,663)	914
		\$ 11,877	\$ (3,964)	\$ 7,913

Amortization expense for intangibles was \$1.3 million in 2018 and \$1.2 million in 2017 and 2016. Amortization expense for the next five years, assuming no change in the estimated useful lives of identified intangible assets, is \$1.1 million in 2019, \$924,000 in 2020, \$809,000 in 2021, \$770,000 in 2022 and \$705,000 in

2023. We completed the acquisition of a business during 2018, and the effects of the purchase price allocation for this transaction on the accompanying consolidated financial statements are not material.

Note 7 Long-Term Debt

Revolving Credit Facility

We have a \$100.0 million revolving credit facility (the "Credit Facility") maturing May 13, 2020 that is used to supplement our operating cash flow and fund our working capital, capital expenditure, general corporate and growth requirements. Advances under the Credit Facility are limited to the lesser of the revolving loan commitment amount (currently \$100.0 million) or a borrowing base amount that is calculated based upon a percentage of eligible receivables and inventories. As of September 29, 2018, no borrowings were outstanding on the Credit Facility, \$98.2 million of borrowing capacity was available and outstanding letters of credit totaled \$1.8 million. As of September 30, 2017, there were no borrowings outstanding on the Credit Facility.

Interest rates on the Credit Facility are based upon (1) an index rate that is established at the highest of the prime rate, 0.50% plus the federal funds rate or the LIBOR rate plus the excess of the then-applicable margin for LIBOR loans over the then-applicable margin for index rate loans, or (2) at our election, a LIBOR rate, plus in either case, an applicable interest rate margin. The applicable interest rate margins are adjusted on a quarterly basis based upon the amount of excess availability on the Credit Facility within the range of 0.25% to 0.75% for index rate loans and 1.25% to 1.75% for LIBOR loans. In addition, the applicable interest rate margins would be increased by 2.00% upon the occurrence of certain events of default provided for under the terms of the Credit Facility. Based on our excess availability as of September 29, 2018, the applicable interest rate margins on the Credit Facility were 0.25% for index rate loans and 1.25% for LIBOR loans.

Our ability to borrow available amounts under the Credit Facility will be restricted or eliminated in the event of certain covenant breaches, events of default or if we are unable to make certain representations and warranties provided for under the terms of the Credit Facility. We are required to maintain a fixed charge coverage ratio of not less than 1.10 at the end of each fiscal quarter for the

twelve-month period then ended when the amount of liquidity on the Credit Facility is less than \$12.5 million. In addition, the terms of the Credit Facility restrict our ability to, among other things: engage in certain business combinations or divestitures; make investments in or loans to third parties, unless certain conditions are met with respect to such investments or loans; pay cash dividends or repurchase shares of our stock subject to certain minimum borrowing availability requirements; incur or assume indebtedness; issue securities; enter into certain transactions with our affiliates; or permit liens to encumber our property and assets. The terms of the Credit Facility also provide that an event of default will occur upon the occurrence of, among other things: defaults or breaches under the loan documents, subject in certain cases to cure periods; defaults or breaches by us or any of our subsidiaries under any agreement resulting in the acceleration of amounts above certain thresholds or payment defaults above certain thresholds; certain events of bankruptcy or insolvency; certain entries of judgment against us or any of our subsidiaries, which are not covered by insurance; or a change of control. As of September 29, 2018, we were in compliance with all of the financial and negative covenants under the Credit Facility and there have not been any events of default.

Amortization of capitalized financing costs associated with the Credit Facility was \$65,000 in 2018, 2017 and 2016. Accumulated amortization of capitalized financing costs was \$4.7 million as of September 29, 2018 and \$4.6 million as of September 30, 2017. We expect the amortization of capitalized financing costs to approximate the following amounts for the next five fiscal years:

Fiscal year	<i>In thousands</i>
2019	\$ 65
2020	41
2021	—
2022	—
2023	—

Note 8 Stock-Based Compensation

Under our equity incentive plan, employees and directors may be granted stock options, restricted stock, restricted stock units and performance awards. Effective February 17, 2015, our shareholders approved the 2015 Equity Incentive Plan of Insteel Industries, Inc. (the "2015 Plan"), which authorizes up to 900,000 shares of our common stock for future grants under the plan. The 2015 Plan, which expires on February 17, 2025, replaces the 2005 Equity Incentive Plan of Insteel Industries, Inc., which expired on February 15, 2015. As of September 29, 2018, there were 334,000 shares of our common stock available for future grants under the 2015 Plan, which is our only active equity incentive plan.

Stock option awards

Under our equity incentive plan, employees and directors may be granted options to purchase shares of common stock at the fair market value on the date of the grant. Options granted under the plan generally vest over three years and expire ten years from the date of the grant. Compensation expense associated with stock options was \$906,000 in 2018, \$1.0 million in 2017 and \$988,000 in 2016. As of September 29, 2018, there was \$262,000 of unrecognized compensation cost related to unvested options which is expected to be recognized over a weighted average period of 1.66 years.

The fair value of each option award granted is estimated on the date of grant using a Monte Carlo valuation model. The weighted-average estimated fair values of stock options granted during 2018, 2017 and 2016 were \$12.06, \$11.08 and \$9.92 per share, respectively, based on the following weighted-average assumptions:

	Year Ended		
	September 29, 2018	September 30, 2017	October 1, 2016
Expected term (in years)	4.79	5.14	5.45
Risk-free interest rate	2.71%	1.98%	1.30%
Expected volatility	37.32%	38.32%	39.00%
Expected dividend yield	0.37%	0.37%	0.48%

The assumptions utilized in the Monte Carlo valuation model are evaluated and revised, as necessary, to reflect market conditions and actual historical experience. The expected term for options was based on the results of a Monte Carlo simulation model, using the model's estimated fair value as an input to the Black-Scholes-Merton model, and then solving for the expected term. The risk-free interest rate for periods within the contractual life of the option was based on the U.S. Treasury yield curve in effect at the time of the grant. The expected volatility was derived using a term structure based on historical volatility and the volatility implied by exchange-traded options on our common stock. The dividend yield was calculated based on our annual dividend as of the option grant date.

The following table summarizes stock option activity:

(Share amounts in thousands)	Options Outstanding	Exercise Price Per Share		Contractual Term - Weighted Average	Aggregate Intrinsic Value (in thousands)
		Range	Weighted Average		
Outstanding at October 3, 2015	923	\$7.55 - \$21.96	\$ 15.14		
Granted	99	23.95 - 34.49	28.47		
Exercised	(651)	7.55 - 21.96	13.93		\$ 8,718
Outstanding at October 1, 2016	371	9.16 - 34.49	20.81		
Granted	88	26.75 - 37.06	30.93		
Exercised	(67)	9.16 - 23.95	19.05		1,212
Outstanding at September 30, 2017	392	9.16 - 37.06	23.40		
Granted	77	29.69 - 41.85	34.84		
Exercised	(196)	9.16 - 37.06	19.68		3,866
Forfeited	(9)	23.95 - 37.06	29.88		
OUTSTANDING AT SEPTEMBER 29, 2018	264	10.23 - 41.85	29.25	7.64 years	1,845
Vested and anticipated to vest in the future at September 29, 2018	262		29.22	7.69 years	1,974
Exercisable at September 29, 2018	109		24.73	5.98 years	1,228

Stock option exercises include "net exercises" for which the optionee received shares of common stock equal to the intrinsic value of the options (fair market value of common stock on the date of exercise less exercise price) reduced by any applicable withholding taxes.

Restricted stock units

Restricted stock units ("RSUs") granted under our equity incentive plan are valued based upon the fair market value on the date of the grant and provide for a dividend equivalent payment which is included in compensation expense. The vesting period for RSUs is generally one year from the date of the grant for RSUs granted to directors and three years from the date of the grant for RSUs granted to employees. RSUs do not have voting rights. RSU grants and compensation expense are as follows:

(In thousands)	Year Ended		
	September 29, 2018	September 30, 2017	October 1, 2016
Restricted stock unit grants:			
Units	35	37	57
Market value	\$ 1,175	\$ 1,180	\$ 1,516
Compensation expense	1,172	1,238	1,451

As of September 29, 2018, there was \$451,000 of unrecognized compensation cost related to unvested RSUs which is expected to be recognized over a weighted average period of 1.74 years.

The following table summarizes RSU activity:

<i>(Unit amounts in thousands)</i>	Restricted Stock Units Outstanding	Weighted Average Grant Date Fair Value
Balance, October 3, 2015	157	\$ 18.96
Granted	57	26.57
Forfeited	(2)	23.95
Released	(67)	17.95
Balance, October 1, 2016	145	22.35
Granted	37	31.95
Released	(54)	20.43
Balance, September 30, 2017	128	25.92
Granted	35	33.52
Forfeited	(3)	29.60
Released	(57)	22.26
BALANCE, SEPTEMBER 29, 2018	103	30.40

Note 9 Income Taxes

The components of the provision for income taxes are as follows:

<i>(Dollars in thousands)</i>	Year Ended		
	September 29, 2018	September 30, 2017	October 1, 2016
Current:			
Federal	\$ 8,265	\$ 8,269	\$ 17,075
State	906	848	1,434
	9,171	9,117	18,509
Deferred:			
Federal	(2,862)	2,455	396
State	55	48	140
	(2,807)	2,503	536
INCOME TAXES	\$ 6,364	\$ 11,620	\$ 19,045
EFFECTIVE INCOME TAX RATE	14.9%	34.0%	33.8%

The reconciliation between income taxes computed at the federal statutory rate and the provision for income taxes is as follows:

<i>(Dollars in thousands)</i>	Year Ended					
	September 29, 2018		September 30, 2017		October 1, 2016	
Provision for income taxes at federal statutory rate	\$ 10,444	24.5%	\$ 11,959	35.0%	\$ 19,701	35.0%
Change in federal tax rate - Tax Cuts and Jobs Act	(3,307)	(7.8)	—	—	—	—
Qualified production activities deduction	(832)	(2.0)	(768)	(2.2)	(1,596)	(2.8)
Excess tax benefits of stock-based compensation	(634)	(1.5)	—	—	—	—
Valuation allowance	(18)	(0.0)	(29)	(0.1)	(213)	(0.4)
State income taxes, net of federal tax benefit	739	1.7	598	1.8	1,093	1.9
Other, net	(28)	(0.0)	(140)	(0.5)	60	0.1
PROVISION FOR INCOME TAXES	\$ 6,364	14.9%	\$ 11,620	34.0%	\$ 19,045	33.8%

The components of deferred tax assets and liabilities are as follows:

<i>(In thousands)</i>	September 29, 2018	September 30, 2017
Deferred tax assets:		
Defined benefit plans	\$ 2,302	\$ 3,556
Accrued expenses and asset reserves	1,939	3,069
Stock-based compensation	1,120	1,907
State net operating loss carryforwards and tax credits	233	284
Valuation allowance	(233)	(251)
DEFERRED TAX ASSETS	5,361	8,565
Deferred tax liabilities:		
Plant and equipment	(9,490)	(15,093)
Prepaid insurance and other reserves	(1,211)	(1,575)
DEFERRED TAX LIABILITIES	(10,701)	(16,668)
NET DEFERRED TAX LIABILITY	\$ (5,340)	\$ (8,103)

On December 22, 2017, the Tax Cuts and Jobs Act (the "Act") was enacted, which, among other changes, reduced the federal statutory corporate tax rate from 35% to 21% effective January 1, 2018. Since our fiscal year ends on the Saturday closest to September 30 rather than the calendar year, we are subject to IRS rules relating to transitional income tax rates. Based on these rules, our federal statutory rate was 24.5% for fiscal 2018 and will be 21% for fiscal 2019 and beyond. Based on the provisions of the Act, we remeasured our deferred tax assets and liabilities and adjusted our estimated annual federal income tax rate to incorporate the lower corporate tax rate into our tax provision during our first fiscal quarter which resulted in a \$3.3 million reduction of income tax expense. We are still in process of evaluating the income tax effect of the Act on the executive compensation limitations that will be effective for our fiscal year 2019.

As of September 29, 2018, we recorded a deferred tax liability (net of valuation allowance) of \$5.3 million in other liabilities on our consolidated balance sheet. As of September 30, 2017, we recorded a deferred tax liability (net of valuation allowance) of \$8.1 million in other liabilities on our consolidated balance sheet. We have \$6.6 million of state net operating loss carryforwards ("NOLs") that begin to expire in 2019, but principally expire between 2019 and 2032. We have also recorded deferred tax assets of \$16,000 for various state tax credits that begin to expire in 2019, but principally expire between 2019 and 2020.

The realization of our deferred tax assets is entirely dependent upon our ability to generate future taxable income in applicable

jurisdictions. GAAP requires that we periodically assess the need to establish a reserve against our deferred tax assets to the extent we no longer believe it is more likely than not that they will be fully realized. As of September 29, 2018, we recorded a valuation allowance of \$233,000 pertaining to various state NOLs and tax credits that were not expected to be utilized. The valuation allowance is subject to periodic review and adjustment based on changes in facts and circumstances and would be reduced should we utilize the state NOLs and tax credits against which an allowance had previously been provided or determine that such utilization was more likely than not. The \$18,000 decrease in the valuation allowance during 2018 is primarily due to the expiration of state NOLs for which an allowance had been previously recorded.

As of September 29, 2018, we had no material, known tax exposures that required the establishment of contingency reserves for uncertain tax positions.

We classify interest and penalties related to unrecognized tax benefits as part of income tax expense. There were no interest and penalties related to unrecognized tax benefits incurred during 2018, 2017 and 2016.

We file U.S. federal income tax returns as well as state and local income tax returns in various jurisdictions. Federal and various state tax returns filed subsequent to 2013 remain subject to examination.

Note 10 Employee Benefit Plans

Retirement plans

We had one defined benefit pension plan, the Insteel Wire Products Company Retirement Income Plan for Hourly Employees, Wilmington, Delaware (the "Delaware Plan"). The Delaware Plan provided benefits for eligible employees based primarily upon years of service and compensation levels. The Delaware Plan was frozen effective September 30, 2008 whereby participants no longer earned additional benefits.

During 2016, we terminated the Delaware Plan and settled plan liabilities through either lump sum distributions to plan participants or annuity contracts purchased from a third-party insurance company that provided for the payment of vested benefits to those participants that did not elect the lump sum option. We made contributions totaling \$1.9 million to the Delaware Plan during 2016.

PART II

Item 8 Financial Statements and Supplementary Data

As a result of the pension termination, unrecognized losses, which previously were recorded in accumulated other comprehensive loss on our consolidated balance sheets, were recognized as expense and a pension plan settlement loss of \$2.5 million was recorded on our consolidated statements of operations for the year ended October 1, 2016.

The reconciliation of the projected benefit obligation, plan assets, funded status and amounts recognized in our consolidated balance sheets for the Delaware Plan is as follows:

<i>(In thousands)</i>	Year Ended October 1, 2016
Change in benefit obligation:	
Benefit obligation at beginning of year	\$ 3,463
Interest cost	147
Actuarial loss	324
Plan settlement	290
Distributions	(4,224)
BENEFIT OBLIGATION AT END OF YEAR	\$ —
Change in plan assets:	
Fair value of plan assets at beginning of year	\$ 2,201
Actual return on plan assets	104
Employer contributions	1,919
Plan settlement	(4,003)
Distributions	(221)
FAIR VALUE OF PLAN ASSETS AT END OF YEAR	\$ —
Reconciliation of funded status to net amount recognized:	
Funded status	\$ —
NET AMOUNT RECOGNIZED	\$ —
Amounts recognized on the consolidated balance sheet:	
Accrued benefit liability	\$ —
Accumulated other comprehensive loss (net of tax)	—
NET AMOUNT RECOGNIZED	\$ —
Amounts recognized in accumulated other comprehensive loss:	
Unrecognized net loss	\$ —
NET AMOUNT RECOGNIZED	\$ —
Other changes in plan assets and benefit obligations recognized in other comprehensive loss:	
Net loss	\$ 685
Amortization of net loss	(76)
Settlement loss	(2,539)
TOTAL RECOGNIZED IN OTHER COMPREHENSIVE INCOME LOSS	\$ (1,930)

Net periodic pension cost for the Delaware Plan includes the following components:

<i>(In thousands)</i>	Year Ended October 1, 2016
Interest cost	\$ 147
Expected return on plan assets	(175)
Settlement loss recognized	2,539
Amortization of net loss	76
NET PERIODIC PENSION COST	\$ 2,587

The assumed discount rate used for the valuation of the Delaware Plan was 3.75% as of October 1, 2016. In establishing the discount rate, we reviewed published market indices of high-quality debt securities, adjusted as appropriate for duration, and high-quality bond yield curves applicable to the expected benefit payments of the Delaware Plan.

Supplemental employee retirement plan

We have Retirement Security Agreements (each, a “SERP”) with certain of our employees (each, a “Participant”). Under the SERPs, if the Participant remains in continuous service with us for a period of at least 30 years, we will pay the Participant a supplemental retirement benefit for the 15-year period following the Participant’s retirement equal to 50% of the Participant’s highest average annual base salary for five consecutive years in the 10-year

period preceding the Participant’s retirement. If the Participant retires prior to the later of age 65 or the completion of 30 years of continuous service with us, but has completed at least 10 years of continuous service, the amount of the Participant’s supplemental retirement benefit will be reduced by 1/360th for each month short of 30 years that the Participant was employed by us.

The reconciliation of the projected benefit obligation, plan assets, funded status and amounts recognized for the SERPs in our consolidated balance sheets is as follows:

(In thousands)	Year Ended		
	September 29, 2018	September 30, 2017	October 1, 2016
Change in benefit obligation:			
Benefit obligation at beginning of year	\$ 9,389	\$ 9,159	\$ 7,821
Service cost	310	344	263
Interest cost	345	338	326
Actuarial loss (gain)	(33)	(162)	1,039
Distributions	(262)	(290)	(290)
BENEFIT OBLIGATION AT END OF YEAR	\$ 9,749	\$ 9,389	\$ 9,159
Change in plan assets:			
Actual employer contributions	\$ 262	\$ 290	\$ 290
Actual distributions	(262)	(290)	(290)
PLAN ASSETS AT FAIR VALUE AT END OF YEAR	\$ —	\$ —	\$ —
Reconciliation of funded status to net amount recognized:			
Funded status	\$ (9,749)	\$ (9,389)	\$ (9,159)
NET AMOUNT RECOGNIZED	\$ (9,749)	\$ (9,389)	\$ (9,159)
Amounts recognized in accumulated other comprehensive loss:			
Unrecognized net loss	\$ 1,966	\$ 2,149	\$ 2,485
NET AMOUNT RECOGNIZED	\$ 1,966	\$ 2,149	\$ 2,485
Other changes in plan assets and benefit obligations recognized in other comprehensive income (loss):			
Net loss (gain)	\$ (33)	\$ (162)	\$ 1,039
Amortization of net loss	(150)	(174)	(85)
TOTAL RECOGNIZED IN OTHER COMPREHENSIVE INCOME (LOSS)	\$ (183)	\$ (336)	\$ 954

Net periodic pension cost for the SERPs includes the following components:

(In thousands)	Year Ended		
	September 29, 2018	September 30, 2017	October 1, 2016
Service cost	\$ 310	\$ 344	\$ 263
Interest cost	345	338	326
Amortization of net loss	150	174	85
NET PERIODIC PENSION COST	\$ 805	\$ 856	\$ 674

The estimated net loss that will be amortized from accumulated other comprehensive loss into net periodic pension cost during 2019 is \$140,000.

The assumptions used in the valuation of the SERPs are as follows:

	Measurement Date		
	September 29, 2018	September 30, 2017	October 1, 2016
Assumptions at year-end:			
Discount rate	4.00%	3.75%	3.75%
Rate of increase in compensation levels	3.00%	3.00%	3.00%

The assumed discount rate is established as of our fiscal year-end measurement date. In establishing the discount rate, we review published market indices of high-quality debt securities, adjusted as appropriate for duration, and high-quality bond yield curves applicable to the expected benefit payments of the SERPs. The SERPs expected rate of increase in compensation levels is based on the anticipated increases in annual compensation.

The projected benefit payments under the SERPs are as follows:

Fiscal year(s)	<i>In thousands</i>
2019	\$ 325
2020	278
2021	245
2022	553
2023	553
2024 - 2028	4,083

Retirement savings plan

In 1996, we adopted the Retirement Savings Plan of Insteel Industries, Inc. (the "Plan") to provide retirement benefits and stock ownership for our employees. The Plan is an amendment and restatement of our Employee Stock Ownership Plan. As allowed under Sections 401(a) and 401(k) of the Internal Revenue Code, the Plan provides for tax-deferred salary deductions for eligible employees.

The Plan allows for discretionary contributions to be made by us as determined by the Board of Directors, which are allocated among eligible participants based on their compensation relative to the total compensation of all participants. Employees are permitted to contribute up to 75% of their annual compensation to the Plan, limited to a maximum annual amount as set periodically by the Internal Revenue Code. We match employee contributions up to 100% of the first 1% and 50% of the next 5% of eligible

compensation that is contributed by employees. Our contributions to the Plan were \$1.1 million in 2018 and 2017 and \$1.0 million in 2016.

Voluntary Employee Beneficiary Associations ("VEBA")

We have a VEBA which allows both us and our employees to make contributions to pay for medical costs. Our contributions to the VEBA were \$5.1 million in 2018, \$5.6 million in 2017 and \$5.4 million in 2016. We are primarily self-insured for our employee's healthcare costs, carrying stop-loss insurance coverage for individual claims in excess of \$175,000 per benefit plan year. Our self-insurance liabilities are based on the total estimated costs of claims filed and claims incurred but not reported, less amounts paid against such claims. We review current and historical claims data in developing our estimates.

Note 11 Commitments and Contingencies

Insurance recoveries

We maintain general liability, business interruption and replacement cost property insurance coverage on our facilities.

In August 2018, a transformer outage and electrical fire occurred at our Dayton, Texas manufacturing facility, which resulted in the temporary curtailment of operations. Alternative power arrangements for the facility were subsequently made, allowing for operations to continue until permanent repairs could be

completed. We are in the process of preparing the supporting analysis for the insurance claim related to the business interruption and property damage resulting from the fire. During 2018, we received \$183,000 of insurance proceeds related to the claim and recorded a \$462,000 receivable for the anticipated insurance proceeds associated with the expenses incurred as of the end of the year. The insurance proceeds attributable to the additional expenses incurred were recorded in cost of sales (\$645,000) on the consolidated statements of operations.

In August 2017, operations at our manufacturing facility located in Dayton, Texas were adversely affected by hurricane Harvey. We are in the process of finalizing the supporting analysis for insurance claims relating to the business interruption and property damage resulting from the storm. During 2018, we received \$439,000 of insurance proceeds related to the claim and recorded a \$52,000 receivable for the anticipated insurance proceeds associated with the expenses that were incurred and capital outlays required to replace property and equipment damaged in the storm. The insurance proceeds attributable to the additional expenses incurred were recorded in cost of sales (\$439,000), SG&A expense (\$26,000) and other income (\$26,000) on the consolidated statements of operations.

We believe the coverage provided for under our insurance policies is sufficient to cover the losses incurred from these claims.

Leases and purchase commitments

We lease a portion of our equipment under operating leases that expire at various dates through 2023. Additionally, we leased our facility in Houston, Texas through September 30, 2017 and subsequently exercised the \$4.9 million purchase option under the lease in October 2017. Under most lease agreements, we pay insurance, taxes and maintenance. Rental expense for operating leases was \$1.5 million in 2018 and \$1.8 million in 2017 and 2016. As of September 29, 2018, minimum rental commitments under all non-cancelable leases with an initial term in excess of one year are payable as follows: 2019, \$1.0 million; 2020 \$543,000; 2021, \$185,000; 2022, \$22,000 and 2023 and beyond, \$16,000.

As of September 29, 2018, we had \$75.1 million in non-cancelable purchase commitments for raw material extending as long as approximately 100 days and \$9.6 million of contractual commitments for the purchase of certain equipment that had not been fulfilled and are not reflected in the consolidated financial statements.

Legal proceedings

We are involved in lawsuits, claims, investigations and proceedings, including commercial, environmental and employment matters, which arise in the ordinary course of business. We do not expect the ultimate outcome or cost to resolve these matters will have a material adverse effect on our financial position, results of operations or cash flows.

Severance and change of control agreements

We have entered into severance agreements with our Chief Executive Officer and Chief Financial Officer that provide them with certain termination benefits in the event their employment with us is terminated without cause. The initial term of each agreement is two years and they automatically renew for successive one year terms unless we or the executive provide notice of termination as specified in the agreement. In the event of termination of the executive's employment without cause, these agreements provide that they would receive termination benefits equal to one and one-half times their annual base salary in effect on the termination date and the continuation of health and welfare benefits for eighteen months. In addition, all of the executive's stock options and restricted stock would vest immediately, and outplacement services would be provided.

We have also entered into change in control agreements with key members of management, including our executive officers, which specify the terms of separation in the event that termination of their employment followed a change in control. The initial term of each agreement is two years and they automatically renew for successive one year terms unless we or the executive provide notice of termination as specified in the agreement. The agreements do not provide assurances of continued employment or specify the terms of an executive's termination should one occur in the absence of a change in control. The compensation payable under the terms of these agreements differs between the Chief Executive Officer and Chief Financial Officer, and the other covered executives. In the event of termination of the Chief Executive Officer or the Chief Financial Officer within two years of a change of control, they would receive severance benefits equal to two times base compensation, two times the average bonus for the prior three years and the continuation of health and welfare benefits for two years. In the event of such a termination of the other key members of management, including our other two executive officers, within two years of a change of control, they would receive severance benefits equal to one times base compensation, one times the average bonus for the prior three years and the continuation of health and welfare benefits for one year. In addition, for any covered executive that is terminated within two years of a change of control, all of their stock options and restricted stock would vest immediately, and outplacement services would be provided.

Note 12 Earnings Per Share

The computation of basic and diluted earnings per share attributable to common shareholders is as follows:

<i>(In thousands, except per share amounts)</i>	Year Ended		
	September 29, 2018	September 30, 2017	October 1, 2016
Net earnings	\$ 36,266	\$ 22,548	\$ 37,245
Basic weighted average shares outstanding	19,079	19,011	18,754
Dilutive effect of stock-based compensation	198	206	301
Diluted weighted average shares outstanding	19,277	19,217	19,055
Net earnings per share:			
Basic	\$ 1.90	\$ 1.19	\$ 1.99
Diluted	1.88	1.17	1.95

Options and RSUs that were antidilutive and not included in the diluted EPS calculation amounted to 83,000 shares in 2018, 76,000 shares in 2017 and 51,000 shares in 2016.

Note 13 Business Segment Information

Our operations are entirely focused on the manufacture and marketing of steel wire reinforcing products for concrete construction applications. Our concrete reinforcing products consist of two product lines: PC strand and WWR. Based on the criteria specified in ASC Topic 280, *Segment Reporting*, we have one reportable segment.

Our net sales and long-lived assets (consisting of net property, plant and equipment, the cash surrender value of life insurance policies, goodwill and intangible assets) by geographic region are as follows:

<i>(In thousands)</i>	Year Ended		
	September 29, 2018	September 30, 2017	October 1, 2016
Net sales:			
United States	\$ 451,418	\$ 387,199	\$ 416,391
Foreign	1,799	1,672	2,156
TOTAL	\$ 453,217	\$ 388,871	\$ 418,547
Long-lived assets:			
United States	\$ 133,913	\$ 122,574	\$ 112,130
Foreign	—	—	—
TOTAL	\$ 133,913	\$ 122,574	\$ 112,130

Our net sales by product line are as follows:

<i>(In thousands)</i>	Year Ended		
	September 29, 2018	September 30, 2017	October 1, 2016
Net sales:			
Welded wire reinforcement	\$ 273,658	\$ 239,522	\$ 256,801
Prestressed concrete strand	179,559	149,349	161,746
TOTAL	\$ 453,217	\$ 388,871	\$ 418,547

There were no customers that accounted for 10% or more of our net sales in 2018, 2017 and 2016.

Note 14 Related Party Transactions

Sales to a company affiliated with one of our directors amounted to \$699,000 in 2018, \$622,000 in 2017 and \$420,000 in 2016.

Note 15 Other Financial Data

Balance sheet information:

<i>(In thousands)</i>	September 29, 2018	September 30, 2017
Accounts receivable, net:		
Accounts receivable	\$ 51,779	\$ 40,485
Less allowance for doubtful accounts	(295)	(201)
TOTAL	\$ 51,484	\$ 40,284
Inventories:		
Raw materials	\$ 61,008	\$ 51,808
Work in process	4,779	2,637
Finished goods	28,370	27,408
TOTAL	\$ 94,157	\$ 81,853
Other current assets:		
Prepaid insurance	\$ 3,845	\$ 3,796
Income taxes receivable	—	925
Other	2,050	1,228
TOTAL	\$ 5,895	\$ 5,949
Other assets:		
Cash surrender value of life insurance policies	\$ 9,769	\$ 9,026
Capitalized financing costs, net	40	105
Other	104	203
TOTAL	\$ 9,913	\$ 9,334
Property, plant and equipment, net:		
Land and land improvements	\$ 14,438	\$ 12,177
Buildings	54,684	50,373
Machinery and equipment	160,068	153,484
Construction in progress	9,672	5,641
	238,862	221,675
Less accumulated depreciation	(132,714)	(123,005)
TOTAL	\$ 106,148	\$ 98,670
Accrued expenses:		
Salaries, wages and related expenses	\$ 6,775	\$ 5,520
Property taxes	1,585	1,384
Customer rebates	1,531	1,015
Sales allowance reserves	804	21
Income taxes	469	—
Workers' compensation	113	116
Other	652	611
TOTAL	\$ 11,929	\$ 8,667
Other liabilities:		
Deferred compensation	\$ 10,541	\$ 9,276
Deferred income taxes	5,340	8,103
TOTAL	\$ 15,881	\$ 17,379

Note 16 Rights Agreement

On April 26, 1999, our Board of Directors declared a dividend distribution of one right per share of our outstanding common stock as of May 17, 1999 pursuant to a Rights Agreement, dated as of April 27, 1999. The Rights Agreement also provides that one right will attach to each share of our common stock issued after May 17, 1999. On April 21, 2009, effective April 25, 2009, our Board of Directors amended the Rights Agreement to, among other changes, extend the final expiration date and adjust the purchase price payable upon exercise of a right.

The rights are not currently exercisable but trade with our common stock shares and become exercisable on the distribution date. The distribution date will occur upon the earliest of 10 business days following a public announcement that either a person or group of affiliated or associated persons (an “acquiring person”) has acquired, or obtained the right to acquire, beneficial ownership of 20% or more (after adjustment for certain derivative transactions) of the outstanding shares of common stock (the “stock acquisition date”), or of a tender offer or exchange offer that would, if consummated, result in an acquiring person beneficially owning 20% or more of such outstanding shares of common stock, subject to certain limitations.

Each right will entitle the holder, other than the acquiring person or group, to purchase one two-hundredths of a share (a “Unit”) of our Series A Junior Participating Preferred Stock (“Preferred Stock”) at a purchase price of \$46 per Unit, subject to adjustment as described in the Rights Agreement (the “purchase price”). At the time specified, each holder of a right will have the right to receive in lieu of Preferred Stock, upon exercise and payment of the purchase price, common stock (or, in certain circumstances,

cash, property or other securities of the Company) having a value equal to two times the purchase price or, at the discretion of the Board, upon exercise and without payment of the purchase price, common stock (or, in certain circumstances, cash, property or other securities of the Company) having a value equal to the difference between the purchase price and the value of the consideration which a person exercising the right and paying the purchase price would receive. Rights that are or (under specified circumstances) were, beneficially owned by any acquiring person will be null and void. The purchase price payable and the number of Units of Preferred Stock or other securities or property issuable upon exercise of the rights are subject to adjustment from time to time. At any time after any person becomes an acquiring person, we may exchange all or part of the rights for shares of common stock at an exchange ratio of one share per right, as appropriately adjusted to reflect any stock dividend, stock split or similar transaction.

In addition, each rights holder, other than an acquiring person, upon exercise of rights will have the right to receive shares of the common stock of the acquiring corporation having a value equal to two times the purchase price for such holder’s rights if we engage in a merger or other business combination where we are not the surviving entity or where we are the surviving entity and all or part of our common stock is exchanged for the stock or other securities of the other company, or if 50% or more of our assets or earning power is sold or transferred.

The rights will expire on April 24, 2019, and may be redeemed by us at any time prior to the distribution date at a price of \$0.005 per right.

Note 17 Product Warranties

Our products are used in applications which are subject to inherent risks including performance deficiencies, personal injury, property damage, environmental contamination or loss of production. We warrant our products to meet certain specifications, and actual

or claimed deficiencies from these specifications may give rise to claims. We do not maintain a reserve for warranties as the historical claims have been immaterial. We maintain product liability insurance coverage to minimize our exposure to such risks.

Note 18 Share Repurchases

On November 18, 2008, our Board of Directors approved a share repurchase authorization to buy back up to \$25.0 million of our outstanding common stock (the “Authorization”). Under the Authorization, repurchases may be made from time to time in the open market or in privately negotiated transactions subject to market conditions, applicable legal requirements and other factors. We are not obligated to acquire any particular amount of common

stock and the program may be commenced or suspended at any time at our discretion without prior notice. The Authorization continues in effect until terminated by the Board of Directors. As of September 29, 2018, there was \$24.8 million remaining available for future share repurchases under this Authorization. There were no share repurchases during 2018, 2017 and 2016.

Report of Independent Registered Public Accounting Firm Consolidated Financial Statements

Board of Directors and Shareholders

Insteel Industries, Inc.:

Opinion on the financial statements

We have audited the accompanying consolidated balance sheets of **Insteel Industries, Inc.** (a North Carolina corporation) and subsidiaries (the “Company”) as of September 29, 2018 and September 30, 2017, the related consolidated statements of operations, comprehensive income, changes in shareholders’ equity, and cash flows for each of the three years in the period ended September 29, 2018, and the related notes and financial statement schedule included under Item 15(a) (collectively referred to as the “financial statements”). In our opinion, the financial statements present fairly, in all material respects, the financial position of the Company as of September 29, 2018 and September 30, 2017, and the results of its operations and its cash flows for each of the three years in the period ended September 29, 2018, in conformity with accounting principles generally accepted in the United States of America.

We also have audited, in accordance with the standards of the Public Company Accounting Oversight Board (United States) (“PCAOB”), the Company’s internal control over financial reporting as of September 29, 2018, based on criteria established in the 2013 *Internal Control—Integrated Framework* issued by the Committee of Sponsoring Organizations of the Treadway Commission (“COSO”), and our report dated October 26, 2018 expressed an unqualified opinion.

Basis for opinion

These financial statements are the responsibility of the Company’s management. Our responsibility is to express an opinion on the Company’s financial statements based on our audits. We are a public accounting firm registered with the PCAOB and are required to be independent with respect to the Company in accordance with the U.S. federal securities laws and the applicable rules and regulations of the Securities and Exchange Commission and the PCAOB.

We conducted our audits in accordance with the standards of the PCAOB. Those standards require that we plan and perform the audit to obtain reasonable assurance about whether the financial statements are free of material misstatement, whether due to error or fraud. Our audits included performing procedures to assess the risks of material misstatement of the financial statements, whether due to error or fraud, and performing procedures that respond to those risks. Such procedures included examining, on a test basis, evidence supporting the amounts and disclosures in the financial statements. Our audits also included evaluating the accounting principles used and significant estimates made by management, as well as evaluating the overall presentation of the financial statements. We believe that our audits provide a reasonable basis for our opinion.

/s/ Grant Thornton LLP

We have served as the Company’s auditor since fiscal 2002.

Charlotte, North Carolina

October 26, 2018

Schedule II - Valuation and Qualifying Accounts Years Ended September 29, 2018, September 30, 2017 and October 1, 2016

ALLOWANCE FOR DOUBTFUL ACCOUNTS

(In thousands)	Year Ended		
	September 29, 2018	September 30, 2017	October 1, 2016
Balance, beginning of year	\$ 201	\$ 291	\$ 638
Amounts charged to earnings	100	(57)	(244)
Write-offs, net of recoveries	(6)	(33)	(103)
BALANCE, END OF YEAR	\$ 295	\$ 201	\$ 291

Item 9 Changes in and Disagreements with Accountants on Accounting and Financial Disclosure

None.

Item 9A Controls and Procedures

Evaluation of Disclosure Controls and Procedures

We have conducted an evaluation of the effectiveness of our disclosure controls and procedures as of September 29, 2018. This evaluation was conducted under the supervision and with the participation of management, including our principal executive officer and our principal financial officer. Based upon that evaluation, our principal executive officer and our principal financial officer concluded that our disclosure controls and procedures were effective to ensure that information required to be disclosed in the reports that we file or submit under the Securities

Exchange Act of 1934, as amended, is recorded, processed, summarized and reported within the time periods specified in the Commission's rules and forms. Furthermore, we concluded that our disclosure controls and procedures were effective to ensure that such information is accumulated and communicated to management, including our principal executive officer and our principal financial officer, as appropriate to allow timely decisions regarding required disclosure.

Management's Report on Internal Control over Financial Reporting

Our management is responsible for establishing and maintaining adequate internal control over financial reporting. Internal control over financial reporting is a process to provide reasonable assurance regarding the reliability of our financial reporting and the preparation of our financial statements for external purposes in accordance with generally accepted accounting principles. Internal control over financial reporting includes: (1) maintaining records that in reasonable detail accurately and fairly reflect the transactions and dispositions of assets; (2) providing reasonable assurance that transactions are recorded as necessary to permit preparation of financial statements in accordance with GAAP, and that receipts and expenditures are made only in accordance with authorizations of management and directors; and (3) providing reasonable assurance that unauthorized acquisition, use or disposition of assets that could have a material effect on financial statements would be prevented or detected on a timely basis. Because of its inherent limitations, internal control over financial reporting can only provide reasonable assurance that a misstatement of financial statements would be prevented or

detected. Also, projections of any evaluation of effectiveness to future periods are subject to the risk that controls may become inadequate because of changes in conditions, or that the degree of compliance with the policies or procedures may deteriorate.

Our management assessed the effectiveness of our internal control over financial reporting based on the criteria set forth by the Committee of Sponsoring Organizations of the Treadway Commission in the 2013 Internal Control – Integrated Framework. Based on this assessment, our management concluded that our internal control over financial reporting was effective as of September 29, 2018. During the quarter ended September 29, 2018, there were no changes in our internal control over financial reporting that have materially affected, or are reasonably likely to materially affect, our internal control over financial reporting.

Our independent registered public accounting firm has issued an audit report on the effectiveness of our internal control over financial reporting as of September 29, 2018, which appears below.

Report of Independent Registered Public Accounting Firm Internal Control Over Financial Reporting

Board of Directors and Shareholders

Insteel Industries, Inc.:

Opinion on internal control over financial reporting

We have audited the internal control over financial reporting of **Insteel Industries, Inc.** (a North Carolina corporation) and subsidiaries (the “Company”) as of September 29, 2018, based on criteria established in the 2013 *Internal Control—Integrated Framework* issued by the Committee of Sponsoring Organizations of the Treadway Commission (“COSO”). In our opinion, the Company maintained, in all material respects, effective internal control over financial reporting as of September 29, 2018, based on criteria established in the 2013 *Internal Control—Integrated Framework* issued by COSO.

We also have audited, in accordance with the standards of the Public Company Accounting Oversight Board (United States) (“PCAOB”), the consolidated financial statements of the Company as of and for the year ended September 29, 2018, and our report dated October 26, 2018 expressed an unqualified opinion on those financial statements.

Basis for opinion

The Company’s management is responsible for maintaining effective internal control over financial reporting and for its assessment of the effectiveness of internal control over financial reporting, included in the accompanying *Management’s Report on Internal Control over Financial Reporting*. Our responsibility is to express an opinion on the Company’s internal control over financial reporting based on our audit. We are a public accounting firm registered with the PCAOB and are required to be independent with respect to the Company in accordance with the U.S. federal securities laws and the applicable rules and regulations of the Securities and Exchange Commission and the PCAOB.

We conducted our audit in accordance with the standards of the PCAOB. Those standards require that we plan and perform the audit to obtain reasonable assurance about whether effective internal control over financial reporting was maintained in all material respects. Our audit included obtaining an understanding

of internal control over financial reporting, assessing the risk that a material weakness exists, testing and evaluating the design and operating effectiveness of internal control based on the assessed risk, and performing such other procedures as we considered necessary in the circumstances. We believe that our audit provides a reasonable basis for our opinion.

Definition and limitations of internal control over financial reporting

A company’s internal control over financial reporting is a process designed to provide reasonable assurance regarding the reliability of financial reporting and the preparation of financial statements for external purposes in accordance with generally accepted accounting principles. A company’s internal control over financial reporting includes those policies and procedures that (1) pertain to the maintenance of records that, in reasonable detail, accurately and fairly reflect the transactions and dispositions of the assets of the company; (2) provide reasonable assurance that transactions are recorded as necessary to permit preparation of financial statements in accordance with generally accepted accounting principles, and that receipts and expenditures of the company are being made only in accordance with authorizations of management and directors of the company; and (3) provide reasonable assurance regarding prevention or timely detection of unauthorized acquisition, use, or disposition of the company’s assets that could have a material effect on the financial statements.

Because of its inherent limitations, internal control over financial reporting may not prevent or detect misstatements. Also, projections of any evaluation of effectiveness to future periods are subject to the risk that controls may become inadequate because of changes in conditions, or that the degree of compliance with the policies or procedures may deteriorate.

/s/ Grant Thornton LLP

Charlotte, North Carolina

October 26, 2018

Item 9B Other Information

None.

PART III

Item 10 Directors, Executive Officers and Corporate Governance

The information called for by this item and not presented herein appears under the captions “Item Number One: Election of Directors”, “Security Ownership of Directors and Executive Officers – Section 16(a) Beneficial Reporting Compliance” and “Corporate Governance Guidelines and Board Matters” in our Proxy Statement for the 2019 Annual Meeting of Shareholders and is incorporated herein by reference. Information on executive officers appears under the caption “Executive Officers of the Company” in Part I of this report.

We have adopted a Code of Business Conduct that applies to all directors, officers and employees, which is available on our website at <https://insteelgcs.gcs-web.com/corporate-governance/governance-documents>. To the extent permissible under applicable law (the rules of the SEC or Nasdaq listing standards), we intend to satisfy the disclosure requirement under Item 5.05 of Form 8-K by posting on our website any amendment or waiver to a provision of our Code of Business Conduct that requires disclosure under applicable law (the rules of the SEC or Nasdaq listing standards). Our website does not constitute part of this Annual Report on Form 10-K.

Item 11 Executive Compensation

The information called for by this item appears under the captions “Executive Compensation”, “Compensation Committee Interlocks and Insider Participation” and “Director Compensation” in our Proxy Statement for the 2019 Annual Meeting of Shareholders and is incorporated herein by reference.

Item 12 Security Ownership of Certain Beneficial Owners and Management and Related Stockholder Matters

The information called for by this item appears under the captions “Security Ownership of Certain Beneficial Owners”, “Security Ownership of Directors and Executive Officers” and “Equity Compensation Plan Information” in our Proxy Statement for the 2019 Annual Meeting of Shareholders and is incorporated herein by reference.

Item 13 Certain Relationships and Related Transactions, and Director Independence

The information called for by this item appears under the captions “Certain Relationships and Related Person Transactions” and “Corporate Governance Guidelines and Board Matters” in our Proxy Statement for the 2019 Annual Meeting of Shareholders and is incorporated herein by reference.

Item 14 Principal Accounting Fees and Services

The information called for by this item appears under the caption “Item Number Three: Ratification of the Appointment of Grant Thornton LLP” in our Proxy Statement for the 2019 Annual Meeting of Shareholders and is incorporated herein by reference.

PART IV

Item 15 Exhibits, Financial Statement Schedules

(a)(1) Financial Statements

The financial statements as set forth under Item 8 are filed as part of this report.

(a)(2) Financial Statement Schedules

Supplemental Schedule II - Valuation and Qualifying Accounts appears on page 46 of this report.

All other schedules have been omitted because they are either not required or not applicable.

(a)(3) Exhibits

The list of exhibits filed as part of this annual report is set forth on the Exhibit Index immediately preceding the signatures to this annual report and is incorporated herein by reference.

(b) Exhibits

See Exhibit Index on pages 50 and 51.

(c) Financial Statement Schedules

See Item 15(a)(2) above.

Item 16 Form 10-K Summary

None.

Exhibit Index

Exhibit Number	Description
2.1	Asset Purchase Agreement between Insteel Wire Products Company and American Spring Wire Corporation dated as of August 9, 2014 (incorporated by reference to Exhibit 2.1 of the Company's Current Report on Form 8-K filed on August 11, 2014).
3.1	Restated Articles of Incorporation for the Company (incorporated by reference to Exhibit 3.1 of the Company's Registration Statement on Form S-1 filed on May 2, 1985).
3.2	Articles of Amendment to the Restated Articles of Incorporation of the Company (incorporated by reference to Exhibit 3.1 of the Company's Current Report on Form 8-K dated May 3, 1988).
3.3	Articles of Amendment to the Restated Articles of Incorporation of the Company (incorporated by reference to Exhibit 3.1 of the Company's Quarterly Report on Form 10-Q for the quarter ended April 3, 1999 filed on May 14, 1999).
3.4	Articles of Amendment to the Restated Articles of Incorporation of the Company (incorporated by reference to Exhibit 3.1 of the Company's Quarterly Report on Form 10-Q for the quarter ended April 3, 2010 filed on April 26, 2010).
3.5	Bylaws of the Company (as last amended December 19, 2016) (incorporated by reference to Exhibit 3.1 of the Company's Quarterly Report on Form 10-Q filed on January 19, 2017).
4.1	Rights Agreement dated April 27, 1999 by and between the Company and First Union National Bank, as Rights Agent (incorporated by reference to Exhibit 99.1 of the Company's Registration Statement on Form 8-A filed on May 7, 1999).
4.2	Amendment No. 1 to the Rights Agreement dated as of April 25, 2009, between the Company and American Stock Transfer & Trust Company, LLC (as Successor Rights Agent to First Union National Bank) (incorporated by reference to Exhibit 4.2 of the Company's Current Report on Form 8-K filed on April 27, 2009).
10.1	Second Amended and Restated Credit Agreement dated as of June 2, 2010, among Insteel Wire Products Company, as Borrower; Insteel Industries, Inc., as a Credit Party; Intercontinental Metals Corporation, as a Credit Party; and General Electric Capital Corporation, as Agent and Lender (incorporated by reference to Exhibit 10.4 of the Company's Quarterly Report on Form 10-Q filed on April 26, 2011).
10.2	First Amendment to Second Amended and Restated Credit Agreement dated as of February 6, 2012, among Insteel Wire Products Company, as Borrower; Insteel Industries, Inc. as a Credit Party; Intercontinental Metals Corporation, as a Credit Party; and General Electric Capital Corporation, as Agent and Lender (incorporated by reference to Exhibit 10.1 to the Company's Current Report on Form 8-K filed on February 6, 2012).
10.3	Second Amendment to Second Amended and Restated Credit Agreement dated as of May 13, 2015, among Insteel Wire Products Company, as Borrower; Insteel Industries, Inc., as a Credit Party; Intercontinental Metals Corporation, as a Credit Party; and General Electric Capital Corporation, as Agent and Lender (incorporated by reference to Exhibit 10.3 to the Company's Current Report on Form 8-K filed on May 14, 2015).
10.4*	Form of Amended and Restated Change in Control Severance Agreements between the Company and each of H.O. Woltz III and Michael C. Gazmarian, respectively, each dated November 14, 2006; each agreement is substantially identical to the form in all material respects (incorporated by reference to Exhibit 99.1 of the Company's Current Report on Form 8-K filed on November 16, 2006).
10.5*	Form of Amended and Restated Severance Agreements with H.O. Woltz III and Michael C. Gazmarian dated November 14, 2006 (each agreement is substantially identical to the form in all material respects) (incorporated by reference to Exhibit 99.6 of the Company's Current Report on Form 8-K filed on November 16, 2006).
10.6*	Change in Control Severance Agreement between the Company and James F. Petelle dated November 14, 2006 (incorporated by reference to Exhibit 99.3 of the Company's Current Report on Form 8-K filed on November 16, 2006).
10.7*	Amended and Restated Retirement Security Agreement by and between the Company and H.O. Woltz III dated September 19, 2007 (incorporated by reference to Exhibit 10.2 of the Company's Current Report on Form 8-K filed on September 21, 2007).
10.8*	Form of Retirement Security Agreement between the Company and each of Michael C. Gazmarian, James F. Petelle and Richard T. Wagner, respectively, dated September 19, 2007; each agreement is substantially identical to the form in all material respects (incorporated by reference to Exhibit 10.3 of the Company's Current Report on Form 8-K filed on September 21, 2007).

Exhibit Number	Description
10.9*	Letter of Employment between the Company and James F. Petelle, dated August 23, 2006 (incorporated by reference to Exhibit 99.7 of the Company's Current Report on Form 8-K filed on November 16, 2006).
10.10*	Relocation Proposal between the Company and James F. Petelle, dated August 23, 2006 (incorporated by reference to Exhibit 10.20.1 of the Company's Annual Report on Form 10-K for the year ended October 3, 2009 filed on November 9, 2009).
10.11*	Addendum to Relocation Proposal between the Company and James F. Petelle, dated September 18, 2009 (incorporated by reference to Exhibit 10.20.2 of the Company's Annual Report on Form 10-K for the year ended October 3, 2009 filed on November 9, 2009).
10.12*	Amended and Restated Change in Control Severance Agreement between the Company and Richard T. Wagner dated November 14, 2006 (incorporated by reference to Exhibit 99.1 of the Company's Current Report on Form 8-K filed on February 15, 2007).
10.13*	2005 Equity Incentive Plan of Insteel Industries, Inc., as amended on November 8, 2011 (incorporated by reference to Exhibit 10.22 to the Company's Annual Report on Form 10-K for the fiscal year ended October 1, 2011 filed on November 10, 2011).
10.14*	Summary of amendments to the Insteel Industries, Inc. Director Compensation Plan (incorporated by reference to exhibit 10.23 of the Company's Annual Report on Form 10-K for the fiscal year ended September 27, 2008 filed on November 18, 2008).
10.15*	Form of Notice of Grant of Restricted Stock Units and Restricted Stock Unit Agreement (incorporated by reference to Exhibit 10.1 of the Company's Current Report on Form 8-K filed on January 23, 2009).
10.16*	Insteel Industries, Inc. Return on Capital Incentive Compensation Plan (as amended and restated effective August 12, 2008) (incorporated by reference to Exhibit 10.1 of the Company's Current Report on Form 8-K filed on February 13, 2009).
10.17*	Form of Amendment to 2005 Equity Incentive Plan of Insteel Industries, Inc. dated August 20, 2013 (incorporated by reference to Exhibit 10.20 of the Company's Annual Report on Form 10-K filed on October 29, 2013).
10.18*	2015 Equity Incentive Plan of Insteel Industries, Inc. (incorporated by reference to Exhibit 99 filed with the Company's Registration Statement on Form S-8, filed with the SEC on February 17, 2015 (File No. 333-202128)).
21.1	List of Subsidiaries of Insteel Industries, Inc. at September 29, 2018.
23.1	Consent of Independent Registered Public Accounting Firm.
31.1	Certification of the Chief Executive Officer pursuant to Rule 13a-14(a) of the Securities Exchange Act of 1934, as adopted pursuant to Section 302 of the Sarbanes-Oxley Act of 2002.
31.2	Certification of the Chief Financial Officer pursuant to Rule 13a-14(a) of the Securities Exchange Act of 1934, as adopted pursuant to Section 302 of the Sarbanes-Oxley Act of 2002.
32.1	Certification of the Chief Executive Officer pursuant to 18 U.S.C. Section 1350, as adopted pursuant to Section 906 of the Sarbanes-Oxley Act of 2002.
32.2	Certification of the Chief Financial Officer pursuant to 18 U.S.C. Section 1350, as adopted pursuant to Section 906 of the Sarbanes-Oxley Act of 2002.
101	The following financial information from our Annual Report on Form 10-K for the fiscal year ended September 29, 2018, filed on October 26, 2018, formatted in XBRL (eXtensible Business Reporting Language) includes: (i) the Consolidated Statements of Operations for the years ended September 29, 2018, September 30, 2017 and October 1, 2016, (ii) the Consolidated Statements of Comprehensive Income for the years ended September 29, 2018, September 30, 2017 and October 1, 2016, (iii) the Consolidated Balance Sheets as of September 29, 2018 and September 30, 2017, (iv) the Consolidated Statements of Cash Flows for the years ended September 29, 2018, September 30, 2017 and October 1, 2016, (v) the Consolidated Statements of Shareholders' Equity as of September 29, 2018, September 30, 2017 and October 1, 2016 and (vi) the Notes to Consolidated Financial Statements.

* Management contracts or compensation plans or arrangements in which directors or executive officers are eligible to participate. Our SEC file number reference for documents filed with the SEC pursuant to the Securities Exchange Act of 1934, as amended, is 1-09929.

Signatures

Pursuant to the requirements of Section 13 or 15(d) of the Securities Exchange Act of 1934, the registrant has duly caused this report to be signed on its behalf by the undersigned thereunto duly authorized.

INSTEEL INDUSTRIES, INC.

Registrant

By: /s/ MICHAEL C. GAZMARIAN

Michael C. Gazmarian

Vice President, Chief Financial Officer and Treasurer

Date: October 26, 2018

Pursuant to the requirements of the Securities Exchange Act of 1934, this report has been signed on October 26, 2018 below by the following persons on behalf of the registrant and in the capacities indicated:

Name and Signature	Position(s)
/s/ H. O. WOLTZ III H. O. Woltz III	<i>President, Chief Executive Officer and Chairman of the Board (Principal Executive Officer)</i>
/s/ MICHAEL C. GAZMARIAN Michael C. Gazmarian	<i>Vice President, Chief Financial Officer and Treasurer (Principal Financial Officer)</i>
/s/ SCOT R. JAFROODI Scot R. Jafroodi	<i>Chief Accounting Officer and Corporate Controller (Principal Accounting Officer)</i>
/s/ ABNEY S. BOXLEY III Abney S. Boxley III	<i>Director</i>
/s/ CHARLES B. NEWSOME Charles B. Newsome	<i>Director</i>
/s/ W. ALLEN ROGERS II W. Allen Rogers II	<i>Director</i>
/s/ JON M. RUTH Jon M. Ruth	<i>Director</i>
/s/ JOSEPH A. RUTKOWSKI Joseph A. Rutkowski	<i>Director</i>
/s/ G. KENNEDY THOMPSON G. Kennedy Thompson	<i>Director</i>

CORPORATE INFORMATION

BOARD OF DIRECTORS

Abney S. Boxley, III^(2,3)

*President and Chief Executive Officer
Boxley Materials Company*

Charles B. Newsome^(1,2,4)

*Executive Vice President
Johnson Concrete Company*

W. Allen Rogers II^(1,3,4)

*Lead Independent Director
Principal
Ewing Capital Partners, LLC
Partner
Peter Browning Partners, LLC*

Jon M. Ruth^(1,2,3)

*Retired Vice President
Cargill*

Joseph A. Rutkowski^(2,3)

*Principal
Winyah Advisors LLC*

G. Kennedy Thompson^(1,2)

*Partner
Aquiline Capital Partners LLC*

H.O. Woltz III⁽⁴⁾

*Chairman, President and
Chief Executive Officer
Insteel Industries, Inc.*

⁽¹⁾ Member of the Audit Committee

⁽²⁾ Member of the Executive Compensation Committee

⁽³⁾ Member of the Nominating and Governance Committee

⁽⁴⁾ Member of the Executive Committee

EXECUTIVE OFFICERS

H.O. Woltz III

*Chairman, President and
Chief Executive Officer*

Michael C. Gazmarian

*Vice President, Chief Financial Officer
and Treasurer*

James F. Petelle

*Vice President—Administration
and Secretary*

Richard T. Wagner

*Vice President and General Manager—
Concrete Reinforcing Products Business
Unit, Insteel Wire Products Company*

SHAREHOLDER INFORMATION

Corporate Headquarters

1373 Boggs Drive
Mount Airy, North Carolina 27030
(336) 786-2141

**Independent Registered Public
Accounting Firm**

Grant Thornton LLP
Charlotte, North Carolina

Annual Meeting

Insteel shareholders are invited to attend our annual meeting, which will be held on Tuesday, February 12, 2019 at 9:00 a.m. ET at the Cross Creek Country Club, 1129 Greenhill Road, Mount Airy, North Carolina 27030.

Common Stock

Insteel's common stock trades on the Nasdaq Global Select Market under the symbol IIN. As of October 23, 2018, there were 550 shareholders of record.

Shareholder Services

For change of name, address or ownership of stock; to replace lost stock certificates; or to consolidate accounts, please contact:
American Stock Transfer & Trust Company
Operations Center
6201 15th Avenue
Brooklyn, New York 11219
(800) 937-5449
www.amstock.com

Investor Relations

For information on Insteel, additional copies of this report or other financial information, contact Michael C. Gazmarian, Vice President, Chief Financial Officer and Treasurer, at our headquarters. You may also visit the Investors section of our web site at <http://insteelgcs.gcs-web.com>.

FORWARD-LOOKING STATEMENTS

Any statements in this 2018 Annual Report that are not entirely historical in nature constitute forward-looking statements within the meaning of the safe harbor provisions of the Private Securities Litigation Reform Act of 1995. For important information regarding forward-looking statements, please read the "Cautionary Note Regarding Forward-Looking Statements" on page 4 of Insteel's Annual Report on Form 10-K for the year ended September 29, 2018, which is included as part of this 2018 Annual Report.



1373 Boggs Drive
Mount Airy, North Carolina 27030
www.insteel.com

